

**Fauna of
New Zealand**
Ko te Aitanga Pepeke
o Aotearoa

'FAUNA' ADVISORY GROUP

**MEMBERS AT DSIR PLANT PROTECTION
/ TE WĀHANGA MANAAKI TUPU
Mount Albert Research Centre
Private Bag, Auckland, New Zealand**

Ex officio

Mr J.F. Longworth, Director (Chairman)

Dr O.R.W. Sutherland, Group Manager, Systematics

Dr P.A. Maddison, Section Leader, Entomology

Co-opted from within Systematics Group

Dr T.K. Crosby, Curator, N.Z. Arthropod Collection

Mr J.S. Dugdale, entomological systematist

UNIVERSITIES REPRESENTATIVE

Dr R.M. Emberson

Entomology Department, Lincoln University
Canterbury, New Zealand

MUSEUMS REPRESENTATIVE

Mr R.L. Palma

Natural History Division
National Museum of New Zealand
P.O. Box 467, Wellington, New Zealand

OVERSEAS REPRESENTATIVE

Dr J.F. Lawrence

CSIRO Division of Entomology
G.P.O. Box 1700, Canberra City
A.C.T. 2601, Australia

**DSIR PLANT PROTECTION
MAORI ADVISORY COMMITTEE**

Mr R. Norman – Ngāti Kuri

Mrs K. Te Hana – Ngāti Whātua

Mrs D. Wihongi – Te Rarawa

Dr M. Walker – Whakatōhea

Mr M. Kendall – Te Rarawa

**SERIES EDITOR
'FAUNA OF NEW ZEALAND'**

Mr C.T. Duval

DSIR Plant Protection / Te Wāhanga Manaaki Tupu
Mount Albert Research Centre, Private Bag, Auckland, New Zealand

Fauna of New Zealand
Ko te Aitanga Pepeke o Aotearoa
Number / Nama 24

Therevidae

(Insecta: Diptera)

L. Lyneborg

Department of Entomology, Zoological Museum
University of Copenhagen, Denmark
Postal address: Zoologisk Museum
Universitetsparken 15, 2100 København

DSIR Plant Protection / Te Wāhanga Manaaki Tupu
Auckland, New Zealand
1992

Cataloguing-in-publication citation / Whakatoopu taa kua perehia - oona maarama tika

LYNEBORG, L.

Therevidae (Insecta: Diptera). -- Auckland : DSIR Plant Protection = Te Wāhanga Manaaki Tupu, 1992.

(Fauna of New Zealand = Ko te Aitanga Pepeke o Aotearoa, ISSN 0111-5383 ; no. 24)

ISBN 0-477-02632-X

I. Title II. Series

UDC 595.772(931)

Date of publication / Waa taa ki te perehi

See 'Titles in Print' notice in subsequent numbers / Tirohia te paanui 'Ingoa Taitara' kua perehia me oona nama

Suggested form of citation / Tohu maarama aahua tika

Lynceborg, L. 1992: Therevidae (Insecta: Diptera). *Fauna of New Zealand / Ko te Aitanga Pepeke o Aotearoa 24.*

Front cover / Aro mua

The insect depicted is / Ko te ngaarara nei a *Anabarhynchus innotatus*, male / taane.

Artist / Toihanga: Des Helmore, DSIR Plant Protection / Te Wāhanga Manaaki Tupu.

© Crown Copyright

Prepared for publication by the Series Editor using computer-based text processing, layout, and printing
Maori text by UniServices Translation Centre, Auckland • Printed by GP Print Limited, Wellington
Published by DSIR Plant Protection / Te Wāhanga Manaaki Tupu
Mt Albert Research Centre, Private Bag, Auckland, New Zealand

Class / Karaaihe **Insecta**
Order / Oota **Diptera**

Family / Whaamere
Therevidae

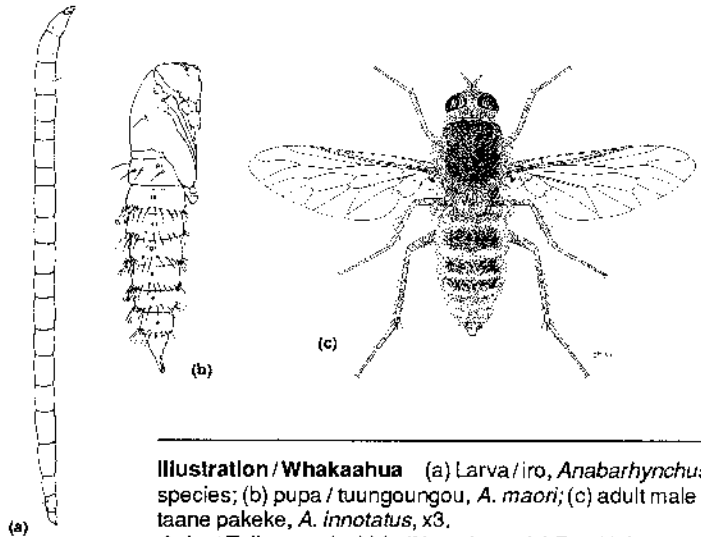

Illustration / Whakaahua (a) Larva / iro, *Anabarhynchus* species; (b) pupa / tuungoungou, *A. maori*; (c) adult male / taane pakeke, *A. innotatus*, x3.

Artist / Toihanga: (a, b) Leif Lyneborg; (c) Des Helmores.

Therevidae or stiletto-flies are distributed worldwide, with some hundreds of species in each major zoogeographical region. The Australian/Oceanian region is probably the richest in Therevidae, with an estimated 600 species. Less than one-fourth of these have so far been described.

The New Zealand fauna of Therevidae is especially rich in relation to the size of the country, and will probably prove to comprise about 100 species when fully explored. This figure equals that for the entire European fauna. At present 69 species have been described and named, 52 of them for the first time as a result of this revision of the family.

These 69 species are placed in only three genera, of which *Anabarhynchus* is by far the largest, with 62 species. The endemic new genus *Megathereva* has been created for three species, and four are placed in *Ectinorhynchus*, a genus with Australian affinities.

Adult Therevidae are rather generalised flies varying in length from 5 mm to 18 mm, and mostly with the abdominal segments rather conspicuously 'furry'. They can be met with in a great variety of habitats, but are relatively seldom seen. Preferred habitats are coastal scrub and sandy ocean beaches, and also sandy lake shores and river beds; wetter habitats are also exploited.

Adults have been collected from September to April, but most abundantly in the months of summer, November to February.

(continued overleaf)

E noho ana nga Therevidae, araa nga ngaro-oka i runga i nga whenua katoa o te ao. He tini nga tuumomo Therevidae i teetahi, i teetahi takiwaa-kararehe nui o te ao. Ko te nuinga pea kei roto i te takiwaa o Ahitereiria me nga whenua o Te Moananui-a-Kiwa. E ono rau pea i te kaute o nga tuumomo [species] i taua takiwaa. E iti iho i te koata o aua tuumomo Therevidae kua aata koorerotia te aahua.

Ahakoia he whenua iti, he maha nga tuumomo Therevidae i Niu Tiireni nei. Teeraa pea ka tae ki te kotahi rau tuumomo aa te waa ka aata koorerotia ai. He taurite teenci ki te tuumomo toopuu kei roto o Oropi katoa. I teenci waa, e ono tekau maa iwa nga tuumomo ngaro-oka kua oti nga aahua te whakaatu, te whakaingoa hoki. Na runga i teenci whakahooutanga i te whaamere, ka kitea tuatahitia, ka aata whakaaturia te aahua, ka whakaingoaia ai hoki, e rima tekau maa rua o nga tuumomo.

Kua whaona nga tuumomo e ono tekau maa iwa nei ki nga hapuu [genera] e toru. Ko *Anabarhynchus* te mea nui rawa o eenei hapuu; e ono tekau maa rua oona tuumomo. Ko *Megathereva* teetahi hapuu houu kua hangaa hei nohanga mo nga tuumomo e toru; ka whaakanohoa hoki nga tuumomo e whaa atu ki roto i *Ectinorhynchus*, teetahi hapuu e whakawhanaunga ana ki eetahi ngaro-oka o Ahitereiria.

He ngaro nga Therevidae, e rima mirimita tae atu ki te tekau maa waru mirimita te roa o nga pakeke; ko te nuinga

(ara haere tonu)

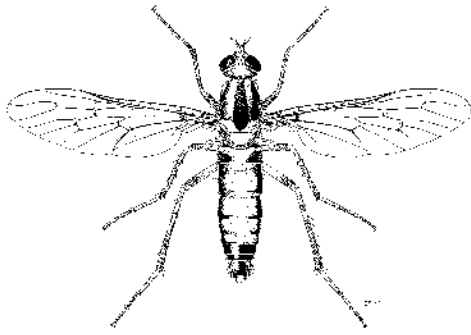

Illustration / Whakaahua *Ectinorhynchus castaneus*, male / taane, x3. Artist / Toihanga: Des Helmore.

The slender, worm-like larvae live in sand or loose soil, are very mobile, and are voracious predators on insect larvae and earthworms. They appear to be 20-segmented, because the 8 abdominal segments are each secondarily constricted. In the prepupal stage the body assumes a U-shaped curvature. The pupal stage lasts for only a week or two, and is especially vulnerable to desiccation and to attack by predators.

There is a great need for more information on the biology of New Zealand's Therevidae.

NOTES FOR COLLECTORS. Adults are readily captured by sweep-netting, and are also often taken in Malaise traps. They should be preserved for study as dry, pinned specimens; moisture can ruin the fine pattern of minute hairs on the body, which may be helpful in identification. Larvae and pupae can be collected by vigorously sifting the top 5–8 cm of substrate in a 20-mesh sieve. Larger larvae and pupae are retained in the sieve, and smaller larvae will appear on top of the sifted soil. Larvae may be cannibalistic, and should be kept in individual tubes.

Contributor Leif Lyneborg studied natural history at the University of Copenhagen, graduating in 1959. Since 1961 he has held the position of Curator of Diptera at the Zoological Museum of that university.

Dr Lyneborg has published nearly one hundred scientific books and papers, dealing mainly with Tabanidae and Therevidae. In the 1960s and 70s he published seven field guides to terrestrial invertebrate faunas of northern and western Europe; these have been translated into several languages. Dr Lyneborg initiated the series 'Fauna entomologica scandinavica' in 1973, and in following years the 'Entomonograph' series, together with several series in Danish. He was Director of Scandinavian Science Press Ltd from 1974 to 1987.

o raatou he puuhuruhuru te puku. E noho ana raatou i nga kaainga maha, engari kaaore e tino kitea ana. Ko te one-tai, ko nga moohuuehu o te aakao, ko nga taha puu-oneone o nga roto, o nga takere awa, koia na nga kaainga e paingia ana. E nohoia ana hoki nga waahi maakuuku.

Kua tangohia nga pakeke i te marama o Hepetema tae atu ki Aperira, engari ko te raumati, ko nga marama o Noema tae atu ki Pepuere te waa e tino kitea ai nga ngaarara nei.

Ko te tamariki he ngaarara toohihi e noho ana i roto i nga onepuu, i nga one punga raanei. He kakama te haere, aa, he nanakia hoki ki te kai i eetahi ngaarara, toke hoki. Ko te aahua e rua tekau nga waahanga e waru o te puku. I mua i te whakarereketanga hei tuungoungou ka huupeke te tinana peenei me te U. Kotahi te wiki, e rua raanei te oranga o te tuungoungou. I teenei waa ko ona mate he maroke, he patunga e te hoariri.

Ko te hiahia kia tupu ai te maatauranga e paa ana ki te aahuatanga me te oranga o nga Therevidae o Niu Tiireni.

PAANUI MO NGA KAI-KOPIKOHU. Ka taaea nga pakeke te kapo ki te kupenga tahitahi, ki te tuumomo taawhiti raanei e kii ana he Malaise trap. Me whakamaroke, me pini hoki kia maatakitaki ai; meena ka maakuu ka kino ai nga huruhuru whakairoiro i runga i te tinana. Na aua huruhuru pea ka kitea ai ko teewhea tuumomo ngaro. Ma te taatari ki te kupenga taatari e rua tekau oona mata ka taaca nga iro me nga tuungoungou te hopu. Me taatari te rima ki te waru hencmita o te oneone, aa, ka mau nga iro nunui me nga tuungoungou i roto i te taatari; ka kitea ai nga iro pakupaku hoki i runga i te oncone i taataritia ai. Kia mau takitahi nga iro i roo ngongo kei kai tectahi i tectahi.

I kuraina te kai-tuhiuhi, a Leif Lyneborg i te whare waananga o Copenhagen; i whiwhi tohu maatauranga i te tau 1959. Mai i te tau 1969 tana tuuranga hei kaitiaki Diptera i te whare taonga o taua whare waanaga.

Kua tata ki te kotahi rau ana pukapuka waananga; e paa ana te nuinga o aua pukapuka ki te Tabanidae me te Therevidae. Mai i te tau 1960 ki te tau 1980 kapua mai ana pukapuka e whitu e whakaatu ana i te aahuatanga o nga ngaarara kore iwi-tuaroa o Ooropi ki te raki me te tuaraki. Kua whakamaaoritia eenei pukapuka ki eetahi reo. Na Taakuta Lyneborg i tiimata nga pukapuka Fauna entomologica scandinavica i te tau 1973, aa, i nga tau tata mai ko nga pukapuka Entomonograph me eetahi pukapuka i te reo o Denmark. Ko ia hoki te Kaiwhakahaere o te Perehi Waananga o Scandinavia mai i te tau 1974 ki 1987.

ABSTRACT

The Therevidae known from New Zealand are revised. Sixty-nine species in three genera are recognised; all species are endemic. Sixty-two species are placed in *Anabarhynchus* Macquart, a large paraphyletic taxon in which the New Zealand stock forms a relatively plesiomorphic clade. *Megathereva* new genus is endemic, and includes three species; its sister-group may be found in the New Zealand *Anabarhynchus* stock. Four species are tentatively placed in *Ectinorhynchus* Macquart; they have affinity with the Australian fauna. Seasonality and geographic distribution are indicated, and keys to the identification of genera and species are given. Details of the male and female terminalia are illustrated for all species. One genus and fifty-two species are described as new. Three new synonymies are proposed in *Anabarhynchus*: *luridus* Schiner and *modestus* Kröber under *innotatus* (Walker), and *thoracicus* Kröber under *neglectus* Kröber.

CHECKLIST OF TAXA

Genus <i>Anabarhynchus</i> Macquart, 1848	22		
<i>acuminatus</i> new species	23	<i>lacustris</i> new species	44
<i>albipennis</i> new species	23	<i>laterepilosus</i> new species	45
<i>arenarius</i> new species	24	<i>latus</i> new species	45
<i>atratus</i> new species	25	<i>limbatinervis</i> Kröber, 1932	46
<i>atripes</i> new species	25	<i>longepilosus</i> new species	47
<i>aureosericeus</i> Kröber, 1932	26	<i>longipennis</i> Kröber, 1932	48
<i>brevicornis</i> new species	27	<i>macfarlanei</i> new species	48
<i>brunninervis</i> Kröber, 1932	28	<i>major</i> new species	49
<i>caesius</i> Kröber, 1912	28	<i>maori</i> Hutton, 1901	50
<i>completus</i> new species	29	<i>frontalis</i> Kröber, 1932	
<i>curvistylus</i> new species	30	<i>megalopyge</i> new species	51
<i>diversicolor</i> new species	31	<i>microphallus</i> new species	52
<i>dugdalei</i> new species	32	<i>monticola</i> new species	52
<i>dysmachiiiformis</i> Kröber, 1932	32	<i>nebulosus</i> Hutton, 1901	53
<i>embersoni</i> new species	33	<i>neglectus</i> Kröber, 1932	54
<i>exiguus</i> Hutton, 1901	34	<i>thoracicus</i> Kröber, 1932 new synonymy	
<i>novazealandiae</i> (Kröber, 1932)		<i>nigrofemoratus</i> Kröber, 1932	55
<i>farinosus</i> new species	34	<i>olivaceus</i> new species	56
<i>femoralis</i> Kröber, 1932	35	<i>ostentatus</i> new species	56
<i>fenwicki</i> new species	36	<i>postocularis</i> new species	57
<i>flaviventris</i> new species	37	<i>robustus</i> new species	58
<i>fluviatilis</i> new species	37	<i>ruficoxa</i> new species	59
<i>fuscofemoratus</i> new species	38	<i>rufobasalis</i> new species	59
<i>gibbsi</i> new species	38	<i>schlingeri</i> new species	60
<i>grossus</i> new species	39	<i>similis</i> new species	61
<i>harrisi</i> new species	40	<i>simplex</i> new species	61
<i>hayakawai</i> new species	40	<i>spiniger</i> new species	62
<i>hudsoni</i> new species	41	<i>spitzeri</i> new species	63
<i>huttoni</i> new species	42	<i>triangularis</i> new species	63
<i>indistinctus</i> new species	42	<i>tricoloratus</i> new species	64
<i>innotatus</i> (Walker, 1856)	43	<i>waitarensis</i> new species	64
<i>luridus</i> Schiner, 1868 new synonymy		<i>westlandensis</i> new species	65
<i>modestus</i> Kröber, 1932 new synonymy		<i>wisei</i> new species	66
		<i>Megathereva</i> new genus	66
		<i>albopilosa</i> new species	67

(<i>Megathereva</i> cont.)	
<i>atritibia</i> new species	68
<i>bilineata</i> (Fabricius, 1775)	69
Genus <i>Ectinorhynchus</i> Macquart, 1850	69
<i>castaneus</i> (Hutton, 1901)	70
<i>cupreus</i> (Hutton, 1901)	71
<i>furcatus</i> new species	71
<i>micans</i> (Hutton, 1901)	72

CONTENTS

Acknowledgments	8
Introduction	8
Systematics	9
Phylogeny	9
Morphology	10
Bionomics	12
Methods and conventions	13
Keys to taxa	15
Descriptions	22
References	73
Illustrations	74
Taxonomic index	134

ACKNOWLEDGMENTS

The initial work for this contribution was done in 1988, when Dr M.E. Irwin of the Illinois Natural History Survey spent nearly 3 months at the Zoological Museum of the University of Copenhagen. Dr Irwin and I jointly examined a large number of Australian and New Zealand therevid taxa in order to obtain some idea of their phylogenetic relationships, both internally and with the faunas of other regions. Mike Irwin is gratefully acknowledged for much fruitful discussion during this initial study.

I am very grateful to the curators and staff of the institutions listed on p. 15 for the loan of material, and to Dr H. Hayakawa, Morioka, Japan and Dr K. Spitzer, České Budejovice, Czechoslovakia for presenting material to the Zoological Museum, University of Copenhagen.

Mr D. Helmore, of DSIR Plant Protection, Auckland, is thanked for the execution of the two habitus drawings, and Mr H. Anthon and Mr R. Nielsen, both of Copenhagen, for preparing the illustrations for the introductory sections.

INTRODUCTION

Therevid flies, or stiletto-flies, are distributed in all zoogeographical regions. About 800 species have been named worldwide. Of these, 134 species originate from the Australian and Oceanian regions (Irwin & Lyneborg 1989), but preliminary work (see Acknowledgments) shows that this figure represents a minor proportion of the existing species – probably only about 25–30%.

The first non-European therevid to be described came from New Zealand: *Bibio bilineata* Fabricius (1775) was described from material in the Banks Collection (now in the BMNH). The second New Zealand species was described as *Thereva innotata* by Walker (1856). The female holotype (BMNH) represents the most widely distributed *Anabarhynchus* species in New Zealand. Schiner (1868) described *Anabarhynchus luridus* on the basis of a female from Auckland, and *A. calceatus* on the basis of three specimens (not conspecific), two from Australia and one from New Zealand. This material is in the NHMW.

Short redescriptions of '*Thereva*' *bilineata* Fabricius and *Anabarhynchus luridus* Schiner were presented by Hutton (1881). Hudson (1892), in his 'Elementary manual' described the preimaginal stages of a therevid under the name "*Saropogon viduus*". Hudson (1950, p. 63) erroneously changed this name to *Anabarhynchus maori* Hutton; it was in fact *Megathereva atritibia*.

In the first real taxonomic treatment of New Zealand therevids, Hutton (1901) recognised nine species, placing all of them in *Anabarhynchus*. Six species – *maori*, *exiguus*, *nebulosus*, *castaneus*, *micans*, and *cupreus* – were described as new. The first three names are valid in *Anabarhynchus*, the last three were placed in combination with *Ectinorhynchus* by Kröber (1932). The type material of Hutton's six species is all well preserved in the CMNZ. Kröber (1912) described *Anabarhynchus caesius* on the basis of one male from "Neuseeland" (NHMW).

A major contribution towards knowledge of the New Zealand therevids was made by Kröber (1932). His paper was based partly on a collection which he had received from the BMNH, and partly on a small collection from "Museum Dahlem" (now IFPE). Eleven species were described as new. The types and other material reported on by Kröber (1932) were found to be well preserved in their respective repositories.

We are thus in the unusual situation of having authentic type material extant for all twenty-two taxa described in Therevidae from New Zealand.

The New Zealand species have been carefully compared with Australian and Chilean species, undescribed as well as described; the papers by Mann (1928, 1929, 1933) have been a useful guide. It seems that all are endemic.

SYSTEMATICS

The name Therevidae originates from *Thereva* Latreille, 1796, and has remained in use unchanged.

Therevidae is recognised as a family of the Asiloidea; its sister-family is undoubtedly Scenopinidae, which is not recorded from New Zealand. The two families share one obviously synapomorphic character: the larval abdominal segments are secondarily segmented, and the abdomen thus appears to have seventeen segments (see Fig. 14).

Diagnostic characters. The features of adult therevids are rather generalised and plesiomorphic. For instance, the wing venation (see Fig. 7) is very similar to that found in Rhagionidae, i.e., with vein R_{4+5} furcate; the second basal cell distally has four corners, from each of which arises a vein; cell m_3 is truncate proximally; and vein CuA_2 joins A_1 near the wing margin. The vertex is not or only slightly concave; the ocellar tubercle is elevated above the dorsal level of the eyes; the face is short and sometimes hairy, but without a mystax (as in Asilidae). The proboscis has well developed labella, and is not equipped for piercing. The empodium is setiform.

The larvae are terrestrial, twenty-segmented and amphipneustic. The metacephalic rod is posteriorly spatulate, projecting into the thorax.

The pupae are free, with a pair of caudal spines except in *Megathereva*. Spiracles are present on the thorax and on abdominal segments 1-7.

PHYLOGENY

Systematic position of Australian/Oceanian therevids

Until recently the Therevidae were without an internal hierarchy; the characters used for separating genera were highly convergent, and resulted in an unnatural classification. Lyneborg (1972, 1976) presented monographic treatments of Afrotropical Therevidae, and a classification of the Nearctic Therevidae was presented by Irwin & Lyneborg (1981). These authors divided the Therevidae into two subfamilies, Phycinae and Therevinae, and described a large number of new genera.

New Zealand therevids belong in subfamily Therevinae, which is characterised by tergite 10 of the female having a group of setae (A_1 setae) set in posterodorsal and posterolateral positions, and a second group of slimmer and often longer setae (A_2 setae) set lateroventrally (see Fig. 11). This character state is certainly a plesiomorphy.

The gonocoxite of all known Therevidae carries on its dorsal margin a complex structure (see Fig. 9). This is composed of (1) a rod-shaped apodeme most anteriorly,

which in some groups has a connecting sclerotised bridge to the aedeagus, (2) a midsection closely fused with the dorsal edge of the gonocoxite, and (3) a distal portion, the dorsal gonocoxal process (or 'outer style' of this paper).

In 1988 Dr M.E. Irwin and I examined the male and female genitalia of most described Australian and Oceanian therevids, and numerous undescribed taxa. These studies produced evidence that the nature and position of the dorsal gonocoxal process (outer style) of Australian/Oceanian therevids is different from that of most non-Australian therevids. In the latter the dorsal gonocoxal process, if present, is shaped as a posteriorly directed style, rather rigidly fixed to the gonocoxite and bearing setae apically. In Australian/Oceanian therevids the dorsal gonocoxal process (outer style) is distinctly articulated with the gonocoxal margin, and is inserted between it and the gonostyle (inner style).

It thus appears as if two styles are present on either side: a true gonostyle (inner style) closest to the midline, and an articulated dorsal gonocoxal process (outer style) more laterad. Dissections show that the gonostyle (inner style) has two antagonistic muscles arising from the inner gonocoxal surface, whereas the dorsal gonocoxal process (outer style) has only one muscle, which probably represents a segregate from the largest of the muscles of the gonostyle (inner style).

It should be noted that the same muscles are present in the gonostyle and dorsal gonocoxal process of a European therevine, *Schoutedenomyia superba* (Kröber), from Greece. The presence of muscles in the gonostyle (inner style) as well as in the dorsal gonocoxal process (outer style) thus seems to belong to the ground-plan of Therevidae (and probably to the Asiloidea).

A formal classification based on the above facts will not be created here, but a taxon characterised by articulated gonocoxal processes (outer styles) will embrace all Australian/Oceanian genera listed by Irwin & Lyneborg (1989) except for *Irwinella* Lyneborg, which is an Old World tropical genus reaching this area only in Papua New Guinea and the Solomon Islands. Also, several genera of the western Neotropical region belong to this taxon.

The internal hierarchy of the Australian/Oceanian therevids is still unknown. On the basis of these studies of New Zealand therevids and also many Australian forms, supplemented with information from English (1950), the following ideas about the basic hierarchy and the major clades have arisen (see also Text-fig. 1).

(1) *Hypopleural pile present / absent*

It seems important to discuss whether the presence of a group of semi-appressed, anteroventrally directed, hair-like setae on the hypopleuron just behind the posterior

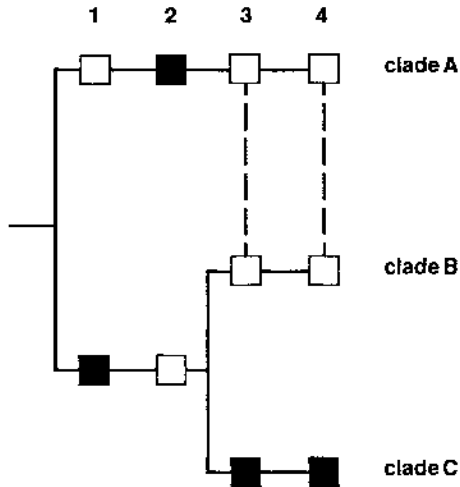

Text-fig. 1 Cladogram showing possible relationship of basic clades of Australian/Oceanian therevids. Clade A includes *Anabarthynchus*, *Megathereva*, *Platycarenum*, and *Eupsilocephala*. Clade B includes *Ectinorhynchus* and a few additional genera. Clade C includes *Agapophytus*, *Acraspisa*, *Acupalpa* and many additional genera of the Australian continent. For discussion of characters 1–4, see text.

spiracle (see Fig. 4, 5) represents a plesiomorphic or an apomorphic character state. Among Australian/Oceanian therevids such a pile is present in all the numerous species described in *Anabarthynchus*, as well as in *Platycarenum* Kröber and *Eupsilocephala* Kröber, both of which comprise but a few species.

An identical hypopleural pile is also present in many therevine genera of other faunas, which supports the idea that the presence of a hypopleural pile is a plesiomorphy, i.e., belongs to the ground-plan of Therevidae. A reduction of the hypopleural pile has occurred independently in most Australian/Oceanian and many non-Australian genera. With regard to the Australian/Oceanian therevids, the presence/absence of a hypopleural pile is an important operational character when sorting material.

(2) Alar process of pupa with spine / without spine

English (1950) describes and illustrates the larvae and pupae of species representing seven Australian genera. A main key character for the pupae is the presence or absence of a spine on the alar process (which is situated at the base of the alar sheath; see Fig. 16). The pupae of *Anabarthynchus maritimus* Hardy and *Platycarenum quinquevittata* (Macquart) both possess a long alar spine, whereas an alar spine is absent in the pupae of the other five genera exam-

ined by English, among them *Ectinorhynchus* Macquart. The alar spine is present in the pupae of three New Zealand *Anabarthynchus* species I have examined, as well as in *Megathereva albopilosa*.

An homologous alar spine is present in the pupae of several Holarctic therevine genera, among others *Thereva* Latrille, *Dialineura* Rondani, *Acrosathe* Irwin & Lyneborg, and *Pandivirilia* Irwin & Lyneborg. On the other hand, the pupae of some South African Xestomyzini (Irwin 1972) and of *Phycus* Walker and *Ataenogera* Kröber (Webb & Irwin 1988), which belong in the Phycinac, do not possess spines on the alar process.

The conclusion must therefore be that the presence of a spine on the alar process at the base of the pupal alar sheath is probably an apomorphic character state.

(3) Cell m_3 open / closed

The presence of an open cell m_3 is without doubt a plesiomorphic character state. On the other hand, the presence of a closed cell m_3 is certainly a weak synapomorphy, because such approximation of veins M_3 and CuA_1 could easily have occurred several times. Both character states occur widely in non-Australian genera. All New Zealand therevids have an open cell m_3 .

(4) Anterior maxillary palps of larva long / minute

English (1950) investigated this character in the larvae of seven Australian genera, and found the maxillary palps to be as long as the basal segment of the labial palp, or longer, in *Anabarthynchus*, *Platycarenum*, *Ectinorhynchus*, and *Taenogera*, whereas they were minute in *Agapophytus*, *Acraspisa*, and *Acupalpa*. No New Zealand larvae have been examined.

MORPHOLOGY

New Zealand therevids are rather generalised, and the following morphological description is based solely on New Zealand taxa.

The body varies in length from 5 mm to 18 mm. The abdomen of *Anabarthynchus* (Fig. 1) is usually rather conical and has a rich pile, whereas in *Ectinorhynchus* (Fig. 2) it is more parallel-sided and less pilose.

The head (Fig. 3) is hemispherical and rather prognathous. The compound eyes are separated in females and separated to nearly touching in males; they lack hairs. There are three usually well developed ocelli on the vertex, but *A. harrisi* shows a tendency towards reduction of the ocelli. The frons, usually entirely tomentose, is subshiny black in *A. maori*. The frontal pile is usually rich, reaching downwards to antennal level. The lateral face is usually free of setae,

but in some *Anabarhynchus* species has a few short setae and in others up to 10–12. The upper occiput has a varying number of pale or black macrosetae, from about 15 to over 50 on either side. In some *Anabarhynchus* species (e.g., *A. atripes*) the occipital macrosetae are hardly distinguishable from the ordinary occipital pile; in others (e.g., *A. postocularis*) the occipital macrosetae are elongate and anteriorly curved. The lower occiput and gena have a rich, black or pale pilosity. The antenna comprises scape, pedicel, and a two- or three-segmented flagellum plus an apical spine. The one-segmented palpus is irregularly vermiform. The proboscis is projecting, with large labella.

The thorax (Fig. 4–6) has a complement of macrosetae as follows: notopleurals (np) 3–8 (if more, considered aberrant); supra-alars (sa) 1–3; postalars 1 or 2; dorsocentrals (dc) 0–3; scutellars (sc) 1–3. The mesonotum and scutellum, in addition to macrosetae, have a complete short pile which may be uniform or composed of two sorts of setae – erect black setae and more appressed, usually pale setae. A pattern of variously coloured tomentum occurs frequently. The pleura may be uniformly tomentose, patterned with variously coloured tomentum, or partly shagbushy to shiny. The mesopleuron and pteropleural callus have long pilosity. The sternopleuron is with or without pilosity. In *Anabarhynchus* and *Megathereva* the hypopleuron (Fig. 5) has a characteristic group of appressed, anteroventrally directed setae; these are absent in *Ectinorhynchus*. The prosternum has pile laterally, but its central depression is with or without pile.

The long, slender legs in New Zealand species are always simple, i.e., without incrustation of tibiae and/or tarsi. The fore coxae have some setae on their anterior surface, and the middle coxae are with or without (Fig. 4) pile on the posterior surface. The femora have a dense pile composed of normal, erect setae and more scale-like, appressed setae; anteroventral (av) macrosetae are usually present on the fore and hind femora and rarely also on the middle femora; posterodorsal (pd) macrosetae are present on the fore femora in several *Anabarhynchus* species; and posteroventral (pv) macrosetae are present on the middle femora of several *Anabarhynchus* species and on the hind femora of nearly all New Zealand species. The tibiae and tarsi are setulose in definite longitudinal rows; the fore tibiae lack setae anteroventrally. There are five tarsomeres; each claw has two pulvilli and a seta-like central empodium.

The wings (Fig. 7) have remarkably uniform venation. The costal setae are arranged in two rows in all New Zealand therevids. Vein R_1 has minute setae on the dorsal surface distally in the *A. nebulosus*-group, but lacks setae in all other New Zealand therevids. Cell m_3 is open in all New Zealand therevids. The wings are hyaline to infusate,

and sometimes banded (*Ectinorhynchus*) or spotted; either the veins are surrounded by darker infuscation, or the cells have darker central areas (*nebulosus*-group). The halteres are well developed.

The abdomen is usually rather convex dorsally in *Anabarhynchus* and *Megathereva*, and more flattened dorsally in *Ectinorhynchus*, but always with eight well developed pregenital segments, although tergite 8 and sternite 8 are shorter. Fine silvery tomentum often adorns the abdomen, covering it completely in the male of many species and in patterns on the female. Other species have dark anterior tergal bands in both sexes, or the abdomen is rather indefinitely patterned. The male genitalia of many *Anabarhynchus* species are more or less concealed in the abdomen, and an anticlockwise rotation of usually less than 90° is often visible; in *Ectinorhynchus* the male genitalia are fully exposed.

The male genitalia (Fig. 8–10) are formed by segments 9–11. A large shield, the epandrium, covers the genitalia dorsally. The epandrium may represent tergite 9 or tergites 9+10, and carries the paired cerci posteriorly. Below the epandrium and the cerci lies the ventral hypandrial sclerite, representing sternites 10+11. In New Zealand therevids this may be variously developed – see the generic descriptions. The hypandrium, or sternite 9, may be well developed and rather discrete in many species, and sometimes has a small field of weak setae. Usually the hypandrium fuses with the anterior edges of the gonocoxites; a few species show a virtual ventral synsclerite, whereas in others the hypandrium is apparently absent. The gonocoxite often has a species-specific posterior extension well beyond the insertion of the gonostyles (= inner style), and has three appendages (Fig. 9). These include ventromedially a ventral lobe that functions as an aedeagal guide, and is simply an offshoot from the gonocoxite. Dorsolaterally is a structure composed of: (1) a rod-shaped apodeme most anteriorly on the gonocoxite, and in some groups with a connecting sclerotised bridge to the aedeagus; (2) a mid-section closely fused with the dorsal edge of the gonocoxite; and (3) a free distal process, which in the present work is termed 'outer style'. The position of this outer style distinguishes Australian/Oceanian therevids (and a few Chilean forms) from therevids of other regions: in the latter the process is usually shaped as a style fixed to the gonocoxal margin, whereas in Australian/Oceanian forms it is articulated with the gonocoxite. The gonostyle (= inner style) is variously shaped, moving in a dorsoventral or oblique direction, and seemingly lying within the female genital cavity during copulation (see Fig. 13). The aedeagus (Fig. 10) consists of a short or long phallic part, which is tube-shaped in *Anabarhynchus* and bulbous in *Ectinorhynchus*, a dorsal apodeme, a simple or forked ventral apo-

deme, a variously shaped ejaculatory apodeme, and a pair of usually band-shaped sclerites below the anterior part of the dorsal apodeme.

The female genitalia (Fig. 11, 12) are formed by segments 9–11. The large, conspicuous sternite 8 offers important specific characters. Sternite 8 comprises the ventral floor of the genital chamber, and in some forms has additional sclerotisations which act as a guide for penial insertion during copulation. The dorsal floor of the genital chamber is strengthened by an oval, ring-shaped sclerite, the furca (= sternite 9). Three unsclerotised spermathecae and two accessory glands are present. Tergite 8 is generally unmodified. Tergite 9 is a single sclerite, generally with extended lateral margins fused to the posterolateral margins of the furca. Tergite 10 is always divided, though often fused with tergite 9, and provided with two sorts of digging or anchoring spines. The so-called A1 setae are heavy, and are directed posterodorsally and posterolaterally; dimensions are given for the third (from above) A1 seta, and it is noted whether it is sharp-pointed or blunt-tipped. The A2 setae are slimmer and directed posterolaterally. Sternites 10 and 11 (= hypoproct or subanal plate) are fused into a single plate, usually well sclerotised. The cerci are paired.

Larvae of New Zealand therevids have not been available, and the following outline is based solely on English (1950). The larva (Fig. 14) is very elongate, cylindrical, tapering at both ends. The head is small, with a well sclerotised cranium composed of an anterior exposed portion tapering strongly towards the mouthparts and a posterior portion which is a long, apically spatulate metacephalic rod projecting into the thorax. The mouthparts comprise a median, slender, tapered labrum flanked by curved, pointed mandibles, and the laciniae and palpi of the maxillae, with elements of the labium ventrally. The labium consists of a large postmentum closing the ventral part of the cranial cavity, a fused pair of labial palpi usually bearing several pairs of setae, and a prementum anteriorly. The cranium externally has several sensory organs both dorsally and ventrally. The antennae are set in crescent-shaped cups on the anterodorsal surface, with one pair of elongate dorsal setae and two pairs of elongate ventral setae. The heavily sclerotised postmentum lies ventrally, and dorsally there are some weakly sclerotised zones called white areas. Two pairs of heavy tentorial arms are present internally.

The thorax has a pair of dorsolateral setae on each segment; the anterior spiracle is distinct, with two or three openings.

Abdominal segments 1–8 are secondarily constricted, giving the appearance of two segments each, which with three thoracic segments and the terminal abdominal segment appear as 20 segments in all. The posterior spiracles

are on the antepenultimate segment, apparently with eight spiracular openings; the terminal segment (Fig. 15) ends in a pair of retractable finger-like processes called prolegs.

Pupae / exuviae of three New Zealand *Anabarhynchus* species and of *Megathereva albopilosa* were available. Study of these revealed important morphological differences between these taxa.

The head of the free pupa (Fig. 16) has a pair of pointed, outward-directed antennal sheaths (Fig. 18, 19) which have a pit-shaped incision behind at the middle bearing a tubular sense organ; a prominence is present proximal to the anterior base of the antennal sheath. The thorax has a pair of spiracles. The alar process is dorsal of the wing sheath, with a shorter or longer, pointed spine; in the unknown New Zealand *Ectinorhynchus* larvae this spine will probably prove to be absent (see English 1950).

The first abdominal segment has one long spine situated posteroventral to the spiracle and three pairs of long dorsal spines; the two more lateral of these lie closer to each other than to the dorsal spine and sometimes more anteriorly. The second and succeeding abdominal segments, except the last, each have a single row of fine, hair-like spines in *Megathereva* (Fig. 21), but these are intermixed with thorn-like protuberances, especially towards the midline, in *Anabarhynchus* (Fig. 22). The lateral lobes of these same segments bear spiracles, and posterior to these from four to seven hair-like spines; a ventral row of similar hair-like spines is present. The terminal segment in *Anabarhynchus* (Fig. 17) ends in two tubercles, each bearing a long caudal spine. This 'ground-plan' condition has been noted for all therevid pupae so far described, and it is therefore of interest to report on the completely differently shaped terminal segment of the *Megathereva* pupa (Fig. 20, 21); see also p. 67.

BIONOMICS

The following notes contain some general information and are based only partly on New Zealand material.

Immature stages. The egg is 0.4–0.8 mm long, ovoid, milky white, and without reticulation. The number of eggs laid by each individual seems to vary from about twenty-five to about a hundred.

As far as is known there are five larval stadia, the last of which either pupates or goes into diapause. Therevids are usually univoltine, but instances where two or more years are needed to complete the life cycle are known in European *Thereva* species, and this may also hold good for some New Zealand species. The snake-like larvae are very mobile,

and move with considerable speed through sand and loose soil. Therevid larvae are voracious predators, feeding on a great variety of insect larvae and earthworms, but preferring Coleoptera larvae. They are cannibalistic, at least when held in captivity. At least one New Zealand species, *A. harrisi* n.sp., has developed a cleptoparasitoid way of life. In the prepupal stage the larva assumes a curved position in the soil, somewhat like the letter U, or almost in a circle.

The pupal stage lasts for only a week or two. The pupa is especially vulnerable to desiccation and to attack by predators.

Adults: habitats. Information on the habitat preferences of New Zealand therevids is very scanty. A large proportion of the *Anabarhynchus* species and all *Megathereva* seem to be associated with coastal scrub and sandy beaches, habitats that are extensively exploited by therevids all over the world. A considerable number of species have been found on inland lake shores and in river beds. Many of the larger and darker *Anabarhynchus* species are probably associated with swampy open mountainsides and tussock country in hilly and mountainous regions. *Anabarhynchus* species can even be found in wet *Nothofagus* rain forest. *A. harrisi* occurs on former glacial plains of the Mackenzie district (see Remarks, p. 40).

Habits. Adult therevids are seemingly all diurnal; however, there are several records of New Zealand *Anabarhynchus* being collected at light during the night. Nothing is known of the food habits of any New Zealand therevids, but therevids seem not to be predaceous, and most species probably imbibe only some water and honeydew. Many taxa inhabiting subtropical regions with winter rain (i.e., parts of California, the Mediterranean area, southwestern Africa, and probably also southwestern Australia) often have an elongated, projecting proboscis, and are recorded as visiting flowers, taking nourishment in the form of nectar.

Adult therevids often alight in sunny patches on trails and paths, or rest on sand, rock, leaves, stems, and tree trunks. They have a rapid flight of short duration. Males of some species form hovering swarms. The female enters a swarm and is caught by a male, and copulation takes place.

To my knowledge the coupling has never been described in any therevid. A coupled pair of *Ectinorhynchus cupreus* is at hand from Trio Island, Cook Strait (Fig. 13). Segment 8 of the male is rotated about 90° to the left (anti-clockwise), and the genitalia are rotated an additional 45° to the left, resulting in 135° of anti-clockwise rotation of the genitalia. There is no apparent vertical grasping effect of the male complex, i.e., of the epandrium against the gonocoxites.

The female S8 is inserted into the male genital complex with its exposed surface placed under the epandrium, intimately facing the ventral epandrial sclerite (= S10+11). The aedeagus and the adjoining, very elongate inner styles (= gonostyles) are inserted into the female genital chamber, which is demarcated dorsally by the furca and ventrally by S8. The aedeagus and inner styles reach about halfway to the anterior margin of the furca, and the inner styles are held approximated to the aedeagus, guided by a pair of grooves in the female S8. The very reduced outer styles have no obvious function, neither for grasping nor for anchoring.

Oviposition behaviour has been described by Irwin (1976). Judged from the morphology of the female genitalia, all New Zealand therevids belong to the group in which the female abdomen is embedded in the substrate by thrusting and contorting it until a major part is buried. As soon as the egg is laid, the abdomen is withdrawn.

Phenology (Text-fig. 2). In New Zealand, adult therevids have been collected from September to April. Three species have been collected during September, sixteen during October, thirty during November, thirty-six during December, thirty-seven during January, thirty during February, thirteen during March, and three during April. The flying period for some of the more common species is usually 3–4 months.

METHODS AND CONVENTIONS

Collecting and preparation. Adults are readily captured by net, and operation of Malaise traps has yielded good results. Care should be taken not to get the specimens wet before pinning them; moisture will ruin the fine pattern of tomentum. Adults should be preserved as dry, pinned specimens. Preparation of genitalia is simple: the apex of the abdomen is removed with fine scissors and cleared in 10% sodium hydroxide solution overnight at ambient temperature. After examination in glycerine the genital structures can be stored in micro-tubes filled with glycerine and attached to the pin with the specimen.

Total length is measured from the base of the antennae to the apex of the abdomen; wing length is measured from the basicoxa to the apex of the wing.

Larvae and pupae can be gathered in the field by shovelling the top 5–8 cm of substrate into a 20-mesh sieve and shaking vigorously until all the finer material has been sieved out. The larger larvae and the pupae can then be removed with forceps and placed in a vial containing sand – only one larva per vial. Smaller larvae will appear on the top of the sifted pile.

The larvae can each be fed with two or three *Tribolium* larvae once a week, and also need a little water every

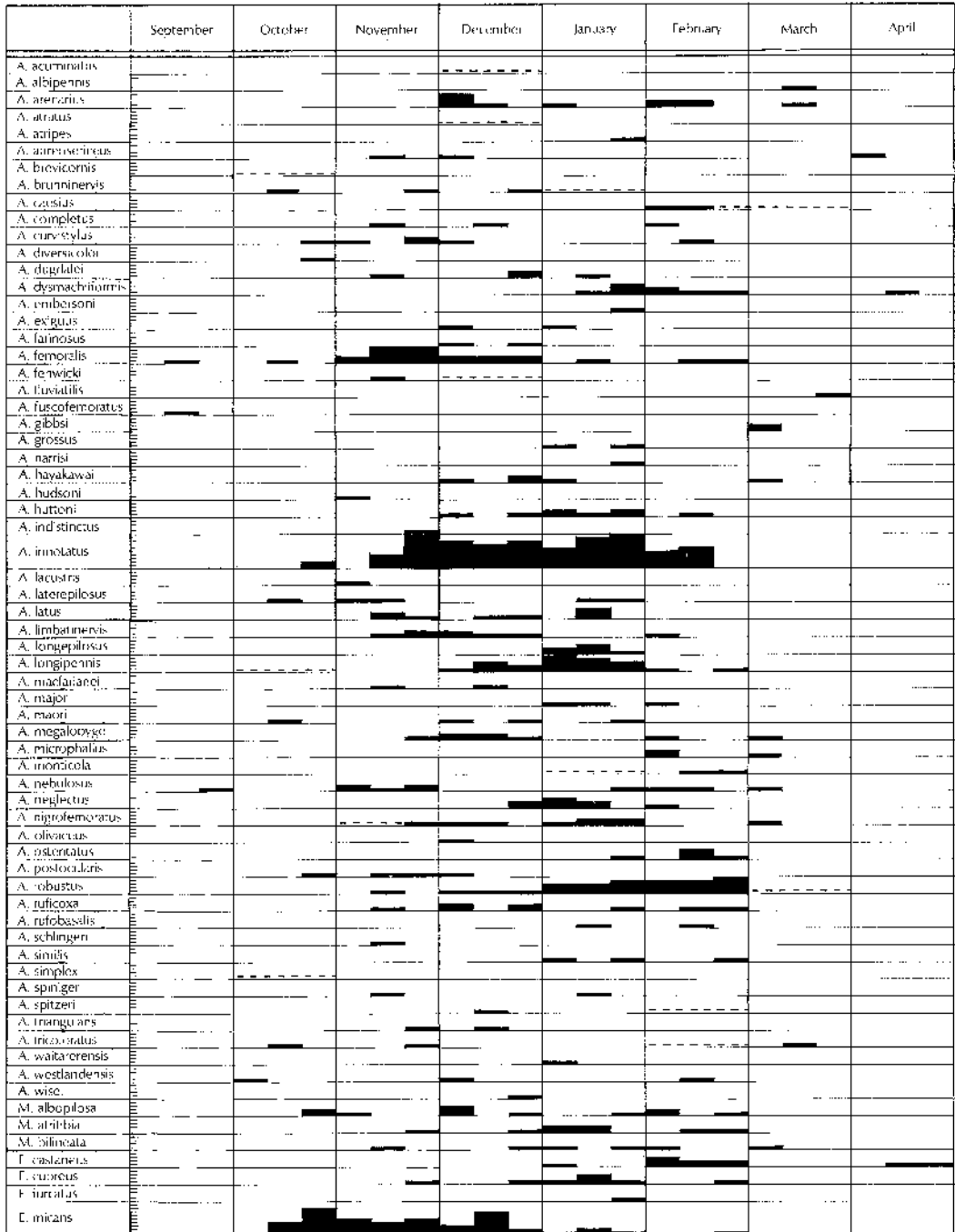

Text-fig. 2 Phenology of New Zealand Therevidae (genera *Anabarhynchus*, *Megathereva*, *Ectinorhynchus*). Each month is divided into 3 periods: 1st–10th, 11th–20th, and 21st–31st. A broken line is used when only the month is indicated. Each unit represents one record, regardless of number of specimens captured.

second day. In New Zealand, larvae collected in September and October could probably be reared without feeding.

Material has increased enormously in the 60 years since Kröber's 1932 paper. Many isolated places have been visited, resulting in small series of undescribed species with probably very restricted distributions. Further collecting will certainly yield several additional undescribed species.

Abbreviations. The two-letter code at the beginning of each record alludes to the areas of New Zealand designated by Crosby *et al.* (1976); see map on p. 137.

Abbreviations for repositories are after Watt (1979):

- AMNZ Auckland Institute and Museum, Private Bag, Auckland, New Zealand
- BMNH British Museum (Natural History), Cromwell Road, London SW7 5BD, England
- BPBM Bernice P. Bishop Museum, Honolulu, Hawaii 96818, U.S.A.
- CASC California Academy of Sciences, San Francisco, CA 94118, U.S.A.
- CISB California Insect Survey, University of California, Berkeley, CA 94720, U.S.A.
- CMNZ Canterbury Museum, Rolleston Ave, Christchurch, New Zealand
- CNCI Canadian National Collection of Insects, Biosystematics Research Institute, Agriculture Canada, Ottawa K1A 0C6, Canada
- CUIC Cornell University Insect Collection, Department of Entomology, Cornell University, Ithaca, NY 14850, U.S.A.
- IFPE Institut für Pflanzenschutzforschung, Abteilung Taxonomie der Insekten, 13 Eberswalde-Finow 1, Schicklerstrasse 5, Germany
- LCNZ Dept. of Entomology, Lincoln College (now Lincoln University), Canterbury, New Zealand
- NHMW Naturhistorisches Museum, Burggring 7, Wien (Vienna) 1, Austria
- NMNZ National Museum of New Zealand, Private Bag, Wellington, New Zealand
- NZAC New Zealand Arthropod Collection, Mt Albert Research Centre, Private Bag, Auckland, New Zealand
- OMNZ Otago Museum, Great King St, Dunedin, New Zealand
- USNM United States National Museum of Natural History, Smithsonian Institution, Washington, D.C. 20560, U.S.A.
- ZMKD Zoologisk Museum, Universitetsparken 15, 2100 København (Copenhagen), Denmark

KEY TO GENERA OF THEREVIDAE KNOWN FROM NEW ZEALAND

- 1 Prosternum with pile on slopes forming a median furrow 2
—Prosternum without pile on slopes forming a median furrow 3
- 2(1) Pile on hind femora uniform, composed of slender, erect to semi-erect, simple setae; middle coxae without pile on posterior surface; very large, heavily built therevids, 15–18 mm in total length *Megathereva*
—Pile on hind femora of 2 kinds: erect, slender hairs and whitish, appressed to semi-appressed, semi-scaly hairs; middle coxae with pile on posterior surface, but often represented by only a few hairs (part) *Anabarhynchus*
- 3(1) Hypopleuron behind posterior spiracle with a group of long, appressed setae which are directed anteriorly and slightly downwards (Fig. 5); pile on hind femora usually of 2 kinds: rather appressed, whitish, semi-scaly setae (especially distinct on dorsal surface) and more erect, usually black, simple setae; aedeagus with phallic part a simple, curved tube; segment 8 of female usually retracted into abdomen (possibly more exposed in copulo) (part) *Anabarhynchus*
—Hypopleuron behind posterior spiracle without setae; hind femora with a uniform pile composed of short to very short, semi-erect, usually black, simple setae; aedeagus with phallic part bulbous, bilobed distally; segment 8 of female fully extended *Ectinorhynchus*

KEY TO SPECIES OF ANABARHYNCHUS KNOWN FROM NEW ZEALAND

- 1 Vein R_1 with minute setae on dorsal surface, at least in section crossing stigma; wings usually with an area of dark microtrichia in centre of each cell; gonocoxite elongate, pointed, divergent 2
—Vein R_1 without setae on dorsal surface; if wing with darker areas, then these arranged as streaks bordering veins, leaving centre of cells more hyaline 6
- 2(1) Mesonotum grey with a pattern of brown stripes . 3
—Mesonotum uniformly grey 5
- 3(2) Femora with yellow-brown ground colour, concolorous with tibiae; mesonotum with tricoloured pattern; notopleural macrosetae 3 pairs; male —epandrium rela-

- tively short (Fig. 195), phallus relatively long (Fig. 197); female – S8 without a strong median posterior knob surrounded by deep incisions, and irregular in profile, lacking a deep impression (Fig. 291); pile differently arranged from other species of *nebulosus*-group (Fig. 290) *tricoloratus*
- Femora with grey-black ground colour; mesonotum with bicoloured pattern; notopleural macrosetae usually 4 pairs; female – S8 with a strong median posterior knob between deep, squarish incisions (Fig. 274) ... 4
- 4(3) Tibiae yellow-brown; frontal pile wholly or partly yellow; female tergites 2 and 3 with tomentum uniformly pale grey and pile exclusively yellow; male – hypandrium well developed (Fig. 157); female – S8 with posterior knob moderately developed (Fig. 274, 275) *nebulosus*
- Tibiae grey-black; frontal pile black; female tergites 2 and 3 with tomentum distinctly darker on anterior parts than along posterior margin, with black pile resulting in a banded appearance; male and female genitalia not clearly distinguishable from those of *nebulosus* *westlandensis*
- 5(2) Vein R₁ with minute setae over entire length; wing cells without darker areas in centre; male – hypandrium not discernible; inner style long relative to outer style (Fig. 52); female – S8 with posterior knob very large, strongly projecting (Fig. 218, 219) *completus*
- Vein R₁ with minute setae only in section crossing stigma; wing cells with 12 dark brown areas arranged in centre; genitalia practically as in *nebulosus*, i.e., with distinct hypandrium in male and a small posterior knob in female (as in Fig. 274, 275) *lacustris*
- 6(1) Prosternum with pile on slopes forming a median furrow 7
- Prosternum without pile on slopes forming a median furrow 13
- 7(6) Femora more or less yellow-brown, thinly white-grey tomentose; male – epandrium suddenly constricted around middle (Fig. 130), and aedeagus with phallic part strongly curved anteriorly (Fig. 132); female – S8 squarish, without a central depression (Fig. 258) *longipennis*
- Femora grey-black 8
- 8(7) A few short, pale or black setae on lateral parts of face; middle femora with from 1 pv seta to several in distal half *innotatus*
- Face without setae; middle femora without pv setae .. 9
- 9(8) Ventral surface of hind femora with pile of long, erect, pale and black or solely black setae at least as long as half femoral width 10
- Ventral surface of hind femora with pile of short, semi-appressed setae at most as long as one-fourth of femoral width 11
- 10(9) Pile of lower occiput, gena, prosternum, and pleura blackish; pile on ventral surface of hind femora composed of blackish setae about half as long as femoral width; male – outer style with apex awl-shaped, inner style with a subapical tooth (Fig. 34) *atratus*
- Pile of lower occiput, gena, prosternum, and pleura whitish; pile on ventral surface of hind femora composed of mixed whitish and blackish setae, some of them as long as femoral width; male – outer style with apex blunt-tipped, inner style without a subapical tooth (Fig. 128) *longepilosus*
- 11(9) Large, heavily built species about 12 mm long; wings practically uniform in coloration, at most with moderately distinct darker streaks along veins; occiput with more than 25 macrosetae on either side; male – outer style with a subapical tooth (Fig. 166), and aedeagus with phallic part suddenly and sharply curved (Fig. 167); female – S8 with a deep, transverse impression in posterior half and a row of normal lateral setae (Fig. 286) *robustus*
- Small, slenderly built species less than 9 mm long; wings with very distinct brown streaks along veins; occiput with less than 25 macrosetae on either side .. 12
- 12(11) Dorsocentral setae absent; mesonotal bands brownish and greyish; middle and hind tibiae usually paler (more brownish) than corresponding femora; male – epandrium heart-shaped (Fig. 111), and gonocoxite strongly extending beyond apex of outer style (Fig. 112); female – S8 as in Fig. 250, 251 *limbatinervis*
- Dorsocentral setae 1 pair; mesonotum with 3 broad, olive grey-yellow bands separated by white-grey stripes; upper parts of frons and occiput olive grey-yellow tomentose; tibiae deep black, concolorous with femora; female – S8 as in Fig. 278, 279 *olivaceus*
- 13(6) Fore femora with at least 1 posterodorsal seta. 14
- Fore femora without posterodorsal setae 34
- 14(13) Ground colour of fore femora blackish, but femora often lightened by grey tomentum and whitish pile; extreme femoral apex sometimes yellowish (i.e., knees yellow) 15

- Ground colour of fore femora more or less yellow-brown; dorsal surface of femora sometimes blackened; often a cover of white-grey tomentum present 32
- 15(14) Fore tibiae brownish, clearly differently coloured from blackish femora; middle coxae without pile on posterior surface 16
 —Fore tibiae blackish, concolorous with femora; middle coxae with pile on posterior surface (? except in *fenwicki*) 17
- 16(15) Halteres blackish; larger species 11–12 mm long, with well marked blackish tergal bands; male – cerci long and sharply pointed (Fig. 102), and hypandrial element with a group of setae (Fig. 103); female – S8 with a double, slightly impressed structure on posterior half, and pile uniform, rich, composed of weak setae (Fig. 248) *hayakawai*
 —Halteres yellow-brown; smaller species 8–9 mm long, with poorly marked darker tergal bands; male – cerci moderately long and pointed (Fig. 108), and hypandrial element without setae (Fig. 109); female – S8 with a single, horseshoe-shaped impression on posterior half, and pile as in *hayakawai*, but sparser (Fig. 246) *huttoni*
- 17(15) Males only (couplets 18–26) 18
 —Females only (couplets 27–31) 27
- 18(17) Basal abdominal tergites with distinct blackish anterior bands, strongly contrasting with white-grey posterior parts 19
 —Abdominal tergites totally white-grey tomentose .. 20
- 19(18) Eyes separated by about width of anterior ocellus; epandrium without a posterolateral lobe; cerci shorter; S11 fused with S10 (Fig. 81) *fenwicki*
 —Eyes separated by twice width of anterior ocellus; epandrium with a posterolateral lobe; cerci elongate; S11 minute, separate from pair of sclerites formed by S10 (Fig. 189) *spitzeri*
- 20(19) Aedeagus with phallic part 'hooded' (Fig. 47, 188) 21
 —Aedeagus with phallic part not 'hooded' 22
- 21(20) Eyes separated by twice width of anterior ocellus; ventral gonocoxal spurs strong, straight (Fig. 58); cerci short, broad (Fig. 45) *brunninervis*
 —Eyes separated by 1.5x width of anterior ocellus; ventral gonocoxal spurs narrow, sharp (Fig. 59); cerci long, slender (Fig. 186) *spiniger*
- 22(20) Eyes separated by 2.5–3.0x width of anterior ocellus; ventral gonocoxal spurs broad (Fig. 115) *indistinctus*
 —Eyes separated by at most width of anterior ocellus .. 23
- 23(22) Aedeagus with phallic part forming a strongly undulating tube (Fig. 161) *ostentatus*
 —Aedeagus with phallic part forming a simple, down-curved tube 24
- 24(23) Epandrium remarkably constricted posteriorly (Fig. 87); gonocoxite strongly projecting posterolaterally, the projection strongly overhanging outer and inner styles (Fig. 88) *fluviatilis*
 —Epandrium of more normal shape; gonocoxite not overhanging outer and inner styles 25
- 25(24) Frontal pile at least partly yellowish; macrosetae of legs at least partly demelanised; inner style without a dorsal lobe (Fig. 31) *arenarius*
 —Frontal pile blackish; macrosetae of legs black; inner style with or without a dorsal lobe 26
- 26(25) Eyes separated by less than width of anterior ocellus; upper anterior facets markedly enlarged; ocelli reduced; inner style with a large dorsal lobe (Fig. 100) *harrisi*
 —Eyes separated by width of anterior ocellus; upper, anterior facets not markedly enlarged; ocelli normally developed; inner style without a dorsal lobe (Fig. 148) *monticola*
- 27(17) Abdomen uniformly greyish; tergites sometimes appearing darker anteriorly than posteriorly, owing to appressed black pile 28
 —Abdominal tergites with black anterior bands, clearly darker anteriorly than on greyish tomentose posterior parts 30
- 28(27) S8 with a large, demelanised triangular area posteriorly; pile restricted to mid-posterior area (Fig. 284) *ostentatus*
 —S8 without a large, demelanised triangular area; pile distributed on most of surface 29
- 29(28) S8 with a pair of demelanised, slightly impressed areas posteriorly, arranged close to midline (Fig. 238) *fluviatilis*
 —S8 without demelanised areas (Fig. 244) *harrisi*
- 30(27) T2–4 with anterior bands divided around midline by greyish tomentum, forming pairs of spots; S8 very

- slightly impressed on middle, with pile restricted to posteromedial area (Fig. 206) *arenarius*
 —T2–4 with dark anterior bands undivided 31
- 31(30) S8 distinctly wider than long, with a pair of demelanised areas along posterolateral margin (Fig. 210) *brunninervis*
 —S8 about as wide as long, with a pair of demelanised, elongate, slightly impressed areas (Fig. 294) *spiniger*
- 32(14) Cell m_3 closed; frons markedly bicoloured, grey-black above and grey-yellow below; male – phallus short, only slightly curved (Fig. 152); female – S8 as in Fig. 268 *microphallus*
 —Cell m_3 open; frons unicolorous, tomentose 33
- 33(34) Occipital macrosetae black; hind femora yellow-brown, with dorsal surface blackened; male – eyes separated by twice width of anterior ocellus, epandrium ‘normal’ (Fig. 27), and outer style wider, with a large, blunt hook (Fig. 28); female unknown *albipennis*
 —Occipital macrosetae whitish; hind femora yellow-brown; male – eyes separated by 3x width of anterior ocellus, epandrium narrow and constricted towards posterior margin (Fig. 63), and outer style slender, with 2 subequal subapical teeth (Fig. 64); female – S8 narrow, with very few setae (Fig. 230) *exiguus*
- 34(13) Ground colour of fore femora blackish, often lightened by grey tomentum and whitish pile; femoral apex sometimes yellowish (i.e., knees yellow) 35
 —Ground colour of fore femora yellow-brown; dorsal surface sometimes blackened, and often with a cover of white-grey tomentum 54
- 35(34) Hind femora with long, whitish or blackish pile on ventral surface; some setae as long as femoral width, arranged nearly perpendicular to femoral axis 36
 —Hind femora with short pile on ventral surface; setae shorter than half femoral width, arranged at about 45° to femoral axis 40
- 36(35) Posterior surface of middle coxae with some pile 37
 —Posterior surface of middle coxae without pile (Fig. 4) 39
- 37(36) Prosternum with a pair of black macrosetae; ventral pile of hind femora whitish; scutellar setae 2 pairs; tergites not markedly banded; female – S8 as in Fig. 304, 305 *wisei*
- Prosternum without macrosetae 38
- 38(37) Ventral pile of hind femora whitish; scutellar setae 3 or 4 pairs; male – genitalia as in Fig. 66–68; female – tergites not markedly banded, and S8 as in Fig. 224, 225 *dugdalei*
 —Ventral pile of hind femora blackish; scutellar setae 2 pairs; male – genitalia as in Fig. 127–129; female – tergites markedly banded, and S8 as in Fig. 260, 261 *longepilosus*
- 39(36) Middle femora without macrosetae; all femora polished black; male – gonocoxites with posterior margin evenly rounded (Fig. 37), and outer style with rather long pilc apically (Fig. 37); female – S8 as in Fig. 208, 209 *atripes*
 —Middle femora with 2–4 strong anteroventral setae; all femora subshiny black, i.e., with thin tomentum; male – gonocoxites with a marked posteromedial extension (Fig. 181), and outer style with very short pile apically (Fig. 181); female – S8 as in Fig. 300, 301 ... *similis*
- 40(35) Upper half or more of frons subshiny blackish, markedly differently coloured from pale grey tomentose lower frons; male – cerci sharply pointed (Fig. 144), outer style with a minute tooth distant from apex (Fig. 145), and aedeagus as in Fig. 146; female – S8 subcircular, with 1 medial and 2 lateral demelanised, slightly impressed areas, and pile of anterior part remarkably long and outstanding (Fig. 266, 267) *maori*
 —Upper part of frons not markedly differently coloured from lower part, i.e., entirely tomentose in grey or grey-brown 41
- 41(40) Middle and hind femora markedly bicoloured, red-yellow in proximal half to three-quarters, blackish distally; male – epandrium shorter than wide and nearly equally wide throughout, cerci very large (Fig. 174), and aedeagus as in Fig. 176; female – S8 as in Fig. 292, 293 *rufobasalis*
 —Middle and hind femora coloured similarly to fore femora 42
- 42(41) Small species 5–9 mm long 43
 —Larger species 10–15 mm long 45
- 43(42) Halteres brown-black; 1st flagellar segment about as wide as long; frontal pile about twice as long as scape; male – outer style very slender, sharp-tipped, inner style with dorsal margin straight (Fig. 184) *simplex*

- Halteres mostly white-yellow, sometimes darker around base of knob; 1st flagellar segment about twice as long as wide; frontal pile about as long as scape 44
- 44(43) Halteres white-yellow; male – abdomen silvery white, epandrium about as wide as long (Fig. 162), outer style moderately thick-bodied, blunt-tipped, and inner style with a sharp dorsal tooth (Fig. 163); female – S8 with very sparse pilosity except on posterior lobe (Fig. 280) *nigrofemoratus*
—Halteres yellowish, with base of knob slightly darkened; male – abdomen with blackish bands, epandrium shorter along midline than wide (Fig. 198), outer style thick-bodied, sharp-tipped, and inner style with dorsal margin straight (Fig. 199); female – S8 more richly pilose (Fig. 306) *waitarerensis*
- 45(42) Frons rather narrow – distance between eyes in front of anterior ocellus 2.0–2.5x (male) or 3.0–4.0x (female) width of ocellus 46
—Frons wider – distance between eyes in front of anterior ocellus 4.0–4.8x (male) or 4.0–5.5x (female) width of ocellus 49
- 46(45) Frontal pile entirely or partly yellowish; abdomen indistinctly banded; male – cerci very large (Fig. 54), outer style remarkably large and elbow-shaped (Fig. 55), and aedeagus with phallic part nearly straight (Fig. 57); female – S8 with posterior half demelanised, less so in middle third (Fig. 222) *curvistylus*
—Frontal pile black; abdomen distinctly banded 47
- 47(46) Mesonotum with a pair of well marked whitish stripes separating 3 brown-black bands; male – outer style remarkably thick-bodied, with a sharp subapical tooth (Fig. 70); female – S8 with very coarse setae (Fig. 226) *dysmachiiformis*
—Mesonotum practically uniformly grey-brown tomentose, at most very indistinctly striped 48
- 48(47) Tergites extensively shiny black, leaving small posterolateral corners greyish tomentose; halteres with knob blackish; mesonotal pile black; male – cerci very sharp (Fig. 102), and outer style with a round-tipped subapical tooth (Fig. 103); female – S8 as in Fig. 248, 249 *hayakawai*
—Tergites with darker areas occupying middle third or so; halteres with knob yellowish, apex and base brownish; mesonotal pile composed of yellowish and blackish setae; male – cerci moderately sharp (Fig. 108), and outer style without a subapical tooth (Fig. 109); female – S8 as in Fig. 246, 247 *huttoni*
- 49(45) Hind femora with black, hair-like, semi-appressed to appressed setae on dorsal and anterior surfaces; dorsocentral macrosetae absent; male – epandrium with posterolateral corners sharply projecting (Fig. 96); female – S8 as in Fig. 242, 243 *grossus*
—Hind femora with predominantly whitish to yellowish, hair-like setae on dorsal and anterior surfaces, those on dorsal surface semi-scaly; dorsocentral macrosetae 1 or 2 pairs 50
- 50(49) Mesonotum with pile on disc composed of black and yellowish setae; male – cerci elongate, sharply pointed (Fig. 72), outer style very slender, with a sharp tooth some distance from apex (Fig. 73), and aedeagus with phallic part long, slender, strongly curved at base (Fig. 74); female – S8 as in Fig. 228, 229 *embersoni*
—Mesonotum with pile on disc black 51
- 51(50) Male – aedeagus with phallic part shaped as a short knifeblade (Fig. 125); female – S8 wider than long (Fig. 254) *latus*
—Male – aedeagus with phallic part tube-shaped; female – S8 about as wide as long 52
- 52(51) Male – gonocoxite with 2 extensions on posterior margin (Fig. 178), parameral apodeme elongate (Fig. 178), and aedeagus with phallic part thick-bodied (Fig. 179); female – S8 with a deep median depression and, anterior to this, a nasiform projection (Fig. 296) *schlingeri*
—Male – gonocoxite with a single extension posteriorly, parameral apodeme short, and aedeagus with phallic part slender; female – S8 with at most a moderate median depression 53
- 53(52) Male – cerci short, blunt-tipped (Fig. 24), and outer style with a reduced apical part (Fig. 25); female – S8 with pile restricted to posterior lobe and a multiserial lateral band (Fig. 204) *acuminatus*
—Male – cerci very long, sharp-tipped (Fig. 93), and outer style with apical part enlarged (Fig. 94); female – S8 with profuse cover of very fine setae (Fig. 240) *gibbsi*
- 54(34) Sternopleuron with long whitish pile on at least upper part 55
—Sternopleuron without pile 56
- 55(54) Frontal pile and occipital setae black; mesonotum practically uniformly coloured; male – epandrium about as wide as long (Fig. 105), and outer style more slender (Fig. 121); female unknown *hudsoni*

- Frontal pile and occipital setae demelanised; mesonotum markedly banded; male – epandrium much wider than long (Fig. 120), and outer style remarkably thick-bodied (Fig. 121); female – S8 as in Fig. 256, 257 *laterepilosus*
- 56(54) Pleura and lateral mesonotal areas with yellow-brown ground colour strongly contrasting with disc of mesonotum; halteres with knob blackish; 1st flagellar segment short relative to width; tergites with marked, shiny black bands; small species 6–8 mm long ... 57
- Pleura and lateral mesonotal areas with blackish ground colour, covered by grey tomentum; halteres with knob usually yellowish (brownish in *megalopyge*, blackish in *macfarlanei*); 1st flagellar segment relatively longer; tergites uniformly greyish tomentose, or at most with dull black bands; usually larger species 58
- 57(56) Frons narrow – eyes in front of anterior ocellus separated by 2.5–3.0x (male) to about 4x (female) width of ocellus; hind femora with stiff black pile on dorsal surface; male – gonocoxites not fused behind hypandrium (Fig. 40); female – S8 with a cup-shaped demelanised area provided with long, anteriorly directed, thin setae but no posteriorly directed lateral setae (Fig. 216) *brevicornis*
- Frons wide – eyes in front of anterior ocellus separated by 4.0–5.0x (male) to 5.2–6.0x (female) width of ocellus; hind femora with semi-scaly whitish pile on dorsal surface; male – gonocoxites fused for some distance behind hypandrium (Fig. 169); female – S8 without a demelanised area, and pile very sparse, comprising a few posteriorly directed lateral setae (Fig. 282) *postocularis*
- 58(56) Middle coxae with some pile on posterior surface 59
- Middle coxae without pile on posterior surface ... 62
- 59(58) Halteres brownish to blackish 60
- Halteres yellowish 61
- 60(59) Male – eyes separated by about 3.7x width of anterior ocellus, pile on ventral surface of hind femora long, erect, epandrium about twice as wide as its length along midline, and cerci short, wide (Fig. 133); female – S8 as in Fig. 262, 263 *macfarlanei*
- Male – eyes separated by 2.1–2.5x width of anterior ocellus, pile on ventral surface of hind femora short, semi-erect, epandrium slightly narrower than its length along midline, and cerci long, slender (Fig. 140); female – S8 as in Fig. 270, 271 *megalopyge*
- 61(59) Pile on ventral surface of hind femora short, semi-appressed, the whitish, hair-like setae as long as half femoral width; scutellar setae 2 pairs; male – outer style with apex simple, and ventral lobe very elongate (Fig. 43); female – S8 reduced, with irregular lateral margins and with pilosity more extended (Fig. 212) *aureosericeus*
- Pile on ventral surface of hind femora long, erect, some of the whitish, hair-like setae as long as femoral width; scutellar setae 3 pairs; male – outer style with a subapical tooth, and ventral lobe of normal size (Fig. 154); female – S8 of normal size, with pile restricted to posterolateral area (Fig. 276) *neglectus*
- 62(58) Ground colour of lateral parts of tergites more or less yellow-brown to yellow-red; sternites at least partly yellow-brown translucent 63
- Tergites and sternites grey-black to white-grey tomentose (except for pale yellow hind marginal seams) 70
- 63(62) Coxae more or less yellow-brown translucent, approaching in colour more the femora than the pleura; scape and pedicellus yellow-brown translucent; male – epandrium as in Fig. 171, cerci with parallel inner margins, and outer style with apex very sharp (Fig. 172); female – S8 as in Fig. 288, 289 *ruficoxa*
- Coxae greyish, as for pleura; scape and pedicellus grey-black to black 64
- 64(63) Middle femora with from 1 posteroventral macroseta to several 65
- Middle femora without posteroventral macrosetae 66
- 65(64) Larger species, wing length 9.0–10.5 mm; male – eyes separated by 2.0–2.5x width of anterior ocellus, and phallus a long, curved tube (Fig. 139); female – S8 as in Fig. 264, 265 *major*
- Smaller species, wing length less than 7 mm; male – eyes separated by over 3x width of anterior ocellus, and phallus very short, only slightly curved (Fig. 152); female – S8 as in Fig. 268, 269 *microphallus*
- 66(64) Thoracic tomentum markedly bicoloured, cinnamon-brown on mesonotum and upper third of mesopleuron, white-grey on remainder of pleura and on coxae; male – cerci elongate, pointed (Fig. 60), gonocoxites with a posteriorly directed extension (Fig. 61), and phallus straight (Fig. 62); female – S8 as in Fig. 220, 221 *diversicolor*
- Thorax in lateral view unicoloured, with tomentum of mesonotum and pleura grey to grey-brown 67

- 67(66) T2–5 in both sexes with continuous dark bands; male – cerci elongate, pointed (Fig. 192) *triangularis*
 —Male – T2–5 with dorsum entirely white-grey to silvery white tomentose, and cerci of normal length; female (*fuscofemoratus* and *flaviventris* unknown) – T2–5 with a pair of dull black spots 68
- 68(67) Male – tergites with dorsum silvery white tomentose, and gonocoxites forming a ventral synsclerite (Fig. 91); smaller species about 8 mm long; female unknown *fuscofemoratus*
 —Male – tergites with dorsum white-grey to grey tomentose, and gonocoxites separated ventrally (Fig. 79, 85); larger species about 10–11 mm long 69
- 69(68) Male – gonocoxite with a postcromedially directed extension (Fig. 79), epandrium short relative to width (Fig. 78), S10 without macrosetae, and aedeagus with phallic part gradually tapering from about middle (Fig. 80); female – S8 with a characteristic uniserial row of setae, directed mesad (Fig. 234) *femoralis*
 —Male – gonocoxite with a posteriorly directed extension (Fig. 85), epandrium longer relative to width (Fig. 84), S10 with a pair of strong macrosetae, and aedeagus with phallic part of even width nearly to apex (Fig. 86); female unknown *flaviventris*
- 70(62) Male – T2–5 dull to subshiny blackish on most of dorsum, eyes separated by 3x width of anterior ocellus, genitalia dark with black pilosity, outer style stout, and inner style with straight dorsal margin (Fig. 49); female – S8 as in Fig. 214, 215 *caesius*
 —Male – T2–5 uniformly greyish tomentose, eyes separated by twice width of anterior ocellus, genitalia yellowish with pale pilosity, outer style narrow, and inner style with a low tooth on dorsal margin (Fig. 76); female – S8 as in Fig. 232, 233 *farinosus*

KEY TO SPECIES OF MEGATHEREVA

- 1 Tibiae uniformly brown-black to black *atrutibia*
 —Tibiae markedly bicoloured, bright yellow-brown for more than proximal half, black distally 2
- 2(1) Pile on prosternum, mesopleuron, and hind femora whitish; scape about twice as long as wide at middle (Fig. 320) *albopilosa*
 —Pile on prosternum, mesopleuron, and hind femora blackish; scape about 3x as long as wide at middle (Fig. 322) *bilineata*

KEY TO SPECIES OF ECTINORHYNCHUS KNOWN FROM NEW ZEALAND

- 1 Thoracic setation: 5–8, usually 6 or 7, notopleural, (1 or 2) supra-alar, 1 postalar, several dorsocentral, and 2 scutellar macrosetae on either side; flagellar style composed of 2 segments plus a terminal spine; pleura uniformly tomentose all over 2
 —Thoracic setation: 3 or 4(–6) notopleural, 1 (or 2) supra-alar, 1 postalar, 0 dorsocentral, and 1 scutellar setae on either side; flagellar style composed of 1 segment plus a terminal spine; pleura more or less shiny, at least on lower mesopleuron 3
- 2(1) Femora unicolorous yellow-brown to brown; male with outer style a rather short, sharp awl solidly fused with gonocoxite, and gonocoxite simply rounded posteriorly (Fig. 325); female S8 as in Fig. 328 *castaneus*
 —Femora, especially fore and middle femora, blackish on dorsal surface and chestnut-brown on ventral surface; male with outer style absent, and gonocoxite with a very large, apically cleft, posterior extension (Fig. 334); (female unknown) *furcatus*
- 3(1) Pleura bicoloured, with a sharp line of demarcation running along upper edge of sternopleuron and further backwards, leaving mesopleuron and other areas above this line shiny brown to black, and areas below tomentose; lower frons shiny black; rather small species less than 9 mm in total length; male – outer style short, claw-shaped, articulated with gonocoxite, inner style very long and slender, and gonocoxite with a long posterior extension (Fig. 330); female – S8 narrow, parallel-sided, with sparse, weak pile (Fig. 332) *cupreus*
 —Pleura largely tomentose, only the mesopleuron with a shiny brown spot on lower part; frons entirely tomentose; larger species 10–12 mm in total length; male – outer style rather long, curved, with an exterior projection at base, partly beset with densely arranged, very short spines, articulated with gonocoxite, inner style large, broad, complicated in shape, and gonocoxite broadly truncate posteriorly (Fig. 338); female – S8 nearly circular in outline, deeply incised posteriorly (Fig. 341) *micans*

DESCRIPTIONS

Genus *Anabarhynchus* Macquart

Anabarhynchus Macquart, 1848: 231, 234. Type species *Anabarhynchus* [sic] *fasciatus* Macquart, 1848, by original monotypy; Tasmania.

Diagnosis. As currently defined, genus *Anabarhynchus* has very wide limits and includes several species-groups. Most of these are restricted to continental Australia and Tasmania. From preliminary examinations the sixty-two New Zealand *Anabarhynchus* species belong in a group which seems not to be represented in continental Australia, but has at least two Tasmanian representatives, *A. nudifemoratus* (Macquart) and *A. terrenus* White; there are also a number of Chilean species. The type species, *A. fasciatus*, does not belong in this group.

In the male terminalia of the *Anabarhynchus*-group embracing the New Zealand species, the outer styles (= gonocoxal processes) are arranged rather horizontally, are more or less finger-shaped, and have at most a sparse, simple apical pile. I regard this as representing the plesiomorphic character state. Consequently, it is not possible to demonstrate monophyly in the group outlined above.

The outer styles of the other Australian and Tasmanian *Anabarhynchus* species show a bewildering array of character states. They may: have strong spines at the apex; form strongly sclerotised, antler-like appendages; be ventrally bent (as in the type species); be strongly reduced; or even apparently be absent.

Description. Habitus as in Fig. 1.

Head (Fig. 3). Eyes in male separated by less than width of anterior ocellus to about 5x width of ocellus, in female by 2–6x width of ocellus. Frons in profile protruding in lower part, and sometimes also in upper part. Frontal pile of varying length. Frons usually tomentose, but partly shiny in *A. maori*. Occipital macrosetae black or demelanised, numbering about 20–50 on either side. Face with from 1 seta to about 10, but usually bare. Scape shorter than 1st flagellomere; flagellar style composed of 2 segments plus a terminal spine. Palpus 1-segmented, vermiform.

Thorax (Fig. 4–6) with great variation in number of macrosetae: np 3–8, sa 1–3, pa 1 or 2, dc 0–3, sc 2 or 3. Prosternum with or without pile in median furrow. Sternopleura with or without pile. Posterior surface of middle coxae with or without pile. (Although the coxae are strictly the basal leg segment, it is convenient here to describe their condition in conjunction with the ventral thorax.)

Legs. Fore femora nearly always with from 1 av macroseta to several; pd macrosetae present or absent. Middle femora without macrosetae, or with from 1 pv macroseta to

several. Hind femora with from 1 to several av and pv macrosetae at apex. Pile of hind femora variable, yielding important specific characters with regard to length of ventral pile and composition of normal and semi-scaly setae on dorsal surface.

Wings (Fig. 7) hyaline or greyish to brownish tinged, often darkened along veins or (*nebulosus*-group) at centre of cells. Vein R_1 with minute setae on dorsal surface in a few species (*nebulosus*-group). Cell m_3 broadly open.

Abdomen usually rather broadly built and densely pilose, in male either entirely white-grey tomentose or showing darker anterior bands (see Fig. 1), in female usually with darker anterior bands.

Male genitalia (Fig. 8–10). Epandrium variously shaped, from about as wide as long to nearly twice as wide as long; pile evenly distributed or more or less restricted in distribution. Cerci variable in shape, from short to very elongate. Ventral epandrial sclerite (= S10+11) usually sclerotised only in posterior section below cerci (= S11); anterior section (= S10) more or less membranous, lying flat under epandrium. Gonocoxites usually rounded posteriorly, but in some species with posterior projections, sometimes clearly separated ventrally, with more or less marked zones of fusion, and sometimes apparently forming a ventral synsclerite (see Fig. 131). A hypandrial element usually distinct as a triangular sclerotisation between anteroventral corners of gonocoxites, sometimes more or less amalgamated with gonocoxites (see Fig. 34), and sometimes apparently absent (see Fig. 55). Outer style (or gonocoxal process) inserted and articulated between dorsal margin of gonocoxite and gonostyle, usually shaped as a pointed finger, and offering important specific distinguishing characters; inner side of apex frequently showing various irregularities like warts or protuberances; pile at apex of outer style usually very sparse and minute, but more developed in *atripes* (see Fig. 37). Inner style (gonostyle) stick-shaped, specifically distinct in some species, as is ventral lobe. Aedeagus (Fig. 10) rather uniform in shape throughout all New Zealand *Anabarhynchus* species, composed of a tube-shaped phallic part, a short dorsal apodeme, a ventral apodeme, an ejaculatory apodeme, and a pair of basiphallic sclerites.

Female genitalia (Fig. 11, 12). Sternite 8 usually species-specific, often possessing 1, 2, or 3 demelanised areas which are usually also devoid of setae. Number, length, orientation, and arrangement of setae highly variable among species. Furca also with possibly species-specific differences, but not further investigated. A1 and A2 setae of tergite 10 varying in number and length among species (species descriptions include measurements of 3rd A1 seta, counted from dorsal end of row, and longest A2 seta).

For additional information, see pp. 12–13.

Anabarhynchus acuminatus new species

Figures 24–26, 204, 205

Male. Head. Eyes separated in front of anterior ocellus by 4.3–4.4X its width. Frons hardly protruding in upper part, gradually protruding towards antennal bases; tomentum pure greyish; pile black; setae about as long as scape. Face bare. Scape greyish; flagellum blackish; terminal flagellar segments together shorter than half length of 1st segment. Occiput with about 35 black macrosetae on either side. Pile of lower occiput and genae whitish. Palpi greyish brown.

Thorax. Macrosetae: np 3 or 4, sa 1 or 2, pa 1, dc 2, sc 2 or 3; all setae black, strong. Mesonotum uniformly dark greyish tomentose; pile moderately long, black on disc, with whitish hair-like setae intermixed laterally and posteriorly. Scutellum coloured like mesonotum, with long whitish pile. Prosternal furrow and sternopleura without pile. Posterior surface of middle coxae with some whitish pile. Pleura and coxae greyish tomentose.

Legs. Fore femora with 1 av macroseta; middle femora without macrosetae, or with 1 or 2 pv; hind femora with 2–4 av and 1 to several pv. Femora and tibiae uniformly grey-black. Pile on ventral surface of hind femora whitish, the setae hair-like, more than half as long as femoral width, on dorsal surface whitish, semi-scaly, with black setae intermixed.

Wings grey-brown hyaline, with pale brownish stigma and veins. Halteres yellowish brown, blackened around base of knob.

Abdomen. T2–5 greyish, indistinctly darkened anteriorly by a combination of slightly darker tomentum and appressed blackish pile; lateral parts of T2–5 and all of T6–7 with whitish pile. Segments 5–7 laterally compressed, with T5 about half as wide as T2. Sternites greyish with white-yellow pile.

Terminalia blackish with black pile. Epandrium (Fig. 24) 1.5X as wide as long; cerci small. Gonocoxites (Fig. 25) connected via a wide hyaline area; hypandrium large, discrete. Outer style with apex reduced and irregularly shaped. Aedeagus (Fig. 26) with phallic part narrow, of even width for a long distance, then tapering to sharp apex.

Female. As for male except as follows. Eyes separated by about 5X width of anterior ocellus. Frons in profile more protruding. Occiput with about 25 macrosetae on either side. One female paratype with 5 np macrosetae on either side, but none with more than 2 sc macrosetae per side. Fore femora often with 2 av macrosetae. Abdominal segments 5–7 with stiff black pile.

Terminalia. S8 in face view (Fig. 204) with a depressed area surrounded by a lateral group of posteromedially directed setae, in profile (Fig. 205) with a marked incurva-

tion of posterior half. Third A1 seta 5–6X as long as wide, narrowly blunt-tipped; 6 or 7 A1 setae per side. Longest A2 seta about 1.8X as long as 3rd A1 seta; 7 A2 setae per side.

Dimensions. Body length 10–12 mm, wing 9.3–9.9 mm.

Type data. Holotype: male, WD, Karangarua River, 12 December 1960, P. Kettle & J.J. Townsend (NZAC).

Paratypes: 1 female, same data as holotype (NZAC); 2 males, 3 females, WD, Makarora, 1000–2000 ft [300–600 m], December 1924, Fenwick Coll. (NMNZ, ZMKD).

Material examined. Type series only.

— / WD / —

Remarks. *A. acuminatus* is clearly a derivative of the widely distributed and more plesiomorphic *A. robustus*, and seems to be very limited in occurrence. The main diagnostic characters separating it from *robustus* are: (a) frons wider; (b) prosternal pile absent; (c) pile of lower occiput, genae, and scutellum whitish (not blackish); (d) abdomen grey tomentose; (e) apex of outer style reduced.

Anabarhynchus albipennis new species

Figures 27–29

Male. Head. Eyes separated in front of anterior ocellus by about twice its width. Frons not protruding, entirely white-grey tomentose; pile of pale-coloured setae shorter than scape. Face bare. Scape grey-white; (flagellum missing). Occiput with about 40 black macrosetae on either side. Pile of lower occiput and genae whitish. Palpi yellowish.

Thorax. Macrosetae: np 4, sa 2, pa 1, dc 2, sc 2; all setae black, strong. Mesonotum with 3 broad, grey-black to grey-brown bands on a pale grey tomentose background; pile black on disc; whitish, hair-like setae predominant anteriorly and posteriorly. Scutellum greyish with brown-black disc; pile whitish, short. Prosternal furrow, sternopleura, and posterior surface of middle coxae without pile. Fore coxae brownish translucent, especially in frontal view; other coxae and pleura greyish tomentose.

Legs. Fore femora with 1 pd macroseta, 1 or 2 av, and 1 pv; middle femora with 2 pv; hind femora with 1 av and 1 pv. Femora mostly yellow-brown, but hind femora blackened on dorsal surface, fore and middle femora less so, and only in apical part. Pile on ventral surface of hind femora whitish, semi-appressed, about half as long as femoral width, that on dorsal surface whitish, semi-scaly, with short, black, normal setae intermixed in distal third.

Wings whitish hyaline with traces of brown along veins; stigma and veins pale brownish. Halteres pale yellowish.

Abdomen. Tergites white-grey tomentose, with weak traces of grey-brown anterior bands on T2-4; lateral parts brownish translucent; pile whitish, short, appressed. Sternites brownish; pile whitish.

Terminalia brownish with white-yellow pile. Epandrium (Fig. 27) 1.4x as wide as long; cerci coarse. Gonocoxites (Fig. 28) broadly rounded posteriorly, fused with large triangular hypandrial element. Outer style with a blunt subapical projection. Aedeagus (Fig. 29) of a generalised type.

Female. Unknown.

Dimensions. Body length about 10 mm, wing 7.5 mm.

Type data. Holotype: male, MK, Lake Pukaki, 20 March 1964, W.J. Thompson (ZMKD).

Material examined. Holotype only.

— / MK / —

Remarks. *A. albipennis* may be the sister-species to *A. hayakawai*; both have an internal subapical projection on the outer style (cf. Fig. 28 and Fig. 103). *A. hayakawai* is in several respects more plesiomorphic, with blackish femora and with pile on the hypandrium.

***Anabarhynchus arenarius* new species**

Figures 30-32, 206, 207

Male. Head. Eyes separated in front of anterior ocellus by less than its width. Frons white-grey tomentose on lower part, dark brownish on upper part; pile restricted to lower frons, shorter than scape, yellowish and/or blackish. Face usually with a few pale setae. Scape white-grey; flagellum black; terminal flagellar segments together about 0.4x as long as 1st segment. Occiput with fewer than 20 macrosetae on either side; setae weak, black or pale, when demelanised difficult to distinguish from other occipital setae. Pile of lower occiput and genae whitish. Palpi grey-brown.

Thorax. Macrosetae: np 3 or 4, sa 2, pa 1, dc 1, sc 2; all setae black, rather strong. Mesonotum variably patterned, either with 3 broad, uniformly grey-brown bands on a pure greyish ground colour, the 2 lateral bands interrupted at notopleural furrow, or midline and lateral areas of the 2 lateral bands with darker brown coloration than the rest. Mesonotal pile rather long, composed of blackish and whitish setae. Scutellum greyish; pile whitish, long. Prosternal furrow and sternopleura without pile; posterior surface of middle coxae with dense whitish pile. Pleura and coxae white-grey tomentose.

Legs. Fore femora with 1 or 2 pd and av macrosetae;

middle femora with 1 or 2 av and pv; hind femora with from 2 to several av, but pv absent or at most weak and hair-like; all femoral and tibial macrosetae black, or pale, or a combination. Femora blackish, with moderate greyish tomentum. Pile on hind femora uniformly whitish, moderately long, appressed to semi-appressed. Tibiae brownish.

Wings grey-brown hyaline with more or less distinct brownish streaks along veins, especially around discal cell; veins brown-black, paler in basal part; stigma brownish. Halteres yellow-brown, blackish around base of knob.

Abdomen white-grey tomentose; pile whitish.

Terminalia mostly grey-black, but epandrium partly brownish; pile whitish. Epandrium (Fig. 30) about as wide as long; cerci about half as long as epandrium. Gonocoxites (Fig. 31) fused together for a long distance; hypandrial element minute. Outer style very slender, its apex sharp. Aedeagus (Fig. 32) of a generalised type.

Female. As for male except as follows. Eyes separated by up to 6x width of anterior ocellus. Frons slightly protruding in lower half; tomentum more or less brownish-tinged on upper part; pile short. Femora often with more av macrosetae than in male. Abdominal dorsum with pairs of blackish spots on T2-4, otherwise greyish tomentose; pile whitish on T1-4, blackish on remaining tergites.

Terminalia. S8 in face view (Fig. 206) with a slight impression on middle of posterior half, in profile (Fig. 207) with a very slight incurvation around middle; pile uniform, rather long, unmodified. Third A1 seta about 6.5x as long as wide, moderately blunt-tipped; 6 A1 setae per side. Longest A2 seta about as long as 3rd A1 seta; only 4 or 5 A2 setae per side.

Dimensions. Body length 8-10 mm, wing 6.8-7.4 mm.

Type data. Holotype: male, DN, Warrington Beach, sand dune area, 3 December 1977, E.I. Schlinger (NZAC).

Paratypes: 1 female, AK, Papakura, 13 February 1973, H. Hayakawa (ZMKD); 1 male, NC, wooded beach nr Kaiapoi, 13 March 1974, ? collector (NZAC); 1 male, MC, Waimairi Co., Spencerville, sandy dunes, 1 December 1974, R.P. Macfarlane (NZAC); 1 male, MC, Christchurch, February 1919, ? collector (ZMKD); 2 males, MC, Christchurch, New Brighton, upper beach, 4 January 1974, R.P. Macfarlane (NZAC); 1 male, MC, Christchurch, Brighton, sand dunes, 6 February 1975, R.P. Macfarlane (NZAC); 10 males, MC, Christchurch, South Brighton, sand dunes, 8 February 1975, R.P. Macfarlane (NZAC); 5 males, MC, Christchurch, Sth Brighton, dunes, 8 December 1974, R.P. Macfarlane (NZAC); 4 males, MC, Christchurch, Taylors Mistake, 13 December 1973, R.L.C. Pilgrim & D.S. Horning (NZAC); 1 male, CO, Kurow River,

Otago, 10 December 1988, A.C. Harris (OMNZ); 1 female, CO, Kurow, 10 December 1988, A.C. Harris & S. Strachn (OMNZ); 1 male, CO, Maniototo Co., Mt Ida, 19 February 1922, ? coll. (AMNZ); 21 males, 11 females, same data as holotype (CISB, NZAC, ZMKD); 1 female, DN, Dunedin, ? date, C.-C. Fenwick (BMNH).

Material examined. Type series only.

— / AK / NC, MC, CO, DN / —

Remarks. *A. arenarius* males are easily recognised by their very narrow frons and the usual demelanisation of the frontal pile, occipital macrosetae, and most femoral and tibial macrosetae.

This seems to be a common species on beaches around Christchurch and Dunedin, but is also known from inland habitats. The sole North Island record is based on a single discoloured female; the genitalia agree with females from Christchurch and Warrington.

At least in the Christchurch area (Brighton sand dunes), *A. arenarius* occurs together with the externally very similar *A. completus*. This is distinguishable from *arenarius* by the minute setae on R_1 , wider frons in the male, absence of pile on the hind surface of the middle coxae, black frontal pile, black macrosetae on the occiput and legs, and characteristically pointed, divergent gonocoxites.

Anabarhynchus atratus new species

Figures 33–35

Male. Head. Eyes separated in front of anterior ocellus by 4.5x its width. Frons brownish tomentose on middle of upper part, greyish tomentose on lower part and along eye margin of upper part; pile black, stiff, erect, rather long. (Antennae missing.) Face bare. Occiput with about 40 short but strong black macrosetae on either side. Pile of lower occiput and genae black. Palpi brown-black.

Thorax. Macrosetae: np 4, sa 2, pa 1, dc 0, sc 2; all setae black, strong. Mesonotum brown-black, subshiny, with 2 narrow, ill marked greyish stripes; pile black, erect, rather long. Scutellum grey-black; pile black. Prosternal furrow with stiff black pile. Sternopleura and posterior surface of middle coxae without pile. Pleura and coxae dark greyish; pile black.

Legs. Right fore femur with 1 av macroseta; left fore femur and middle femora without macrosetae; hind femora with 1 short pv at apex. Femora and other parts of legs blackish; pile blackish. Pile on ventral surface of hind femora erect, longer than half femoral width, on dorsal surface semi-erect, with no appressed semi-scaly setae.

Wings grey-brown hyaline, with narrow brownish streaks

along veins of proximal half; veins and stigma dark brownish. Halteres dirty yellow-brown, blackish around base of knob.

Abdomen. T2–6 with blackish, subshiny anterior bands occupying 65–75% of tergal length, narrowing strongly laterally and leaving entire lateral parts of tergites blue-grey tomentose; pile black. Sternites grey-black; pile yellowish.

Terminalia blackish; pile black. Epandrium (Fig. 33) about 1.5x as wide as long; cerci short. Gonocoxites (Fig. 34) simply rounded posteriorly, intimately fused with hypandrial element. Outer style with apex very sharp; inner style with a low dorsal tooth near apex. Aedeagus (Fig. 35) with phallic part relatively short; basiphallic sclerites remarkably large.

Female. Unknown.

Dimensions. Body length about 10 mm, wing 7.5 mm.

Type data. Holotype: male, NC–WD, Arthurs Pass, 2500' [750 m], 25 December 1922, J. Muggeridge (NZAC).

Material examined. Holotype only.

— / NC–WD / —

Remarks. *A. atratus* probably represents a plesiomorphic branch of *Anabarhynchus*, close to the ancestral New Zealand form. It may be the sister-species to the group formed by *atripes* and *similis*. The holotype was identified as *Anabarhynchus maori* Hutton by Kröber.

Anabarhynchus atripes new species

Figures 36–38, 208, 209

Male. Head. Eyes separated in front of anterior ocellus by twice its width. Frons grey-brown tomentose, narrowly protruding in lower part; pile black, erect; setae longer than scape. Face bare. Scape grey-black; flagellum black; terminal flagellar segments together about half as long as 1st segment. Occipital setae numerous, mostly weak and hair-like, only some of the upper ones macrosetae. Pile of lower occiput and genae mainly whitish, but some blackish pile present below eyes. Palpi grey-black.

Thorax. Macrosetae: np 4 or 5, sa 2, pa 1, dc 0, sc 3 (or 4); all macrosetae black, relatively weak, those on scutellum irregularly arranged. Mesonotum and scutellum practically uniformly grey-brown tomentose, with weak traces of 2 paler stripes on mesonotum; pile long, black, erect. Prosternal furrow, sternopleura, and posterior surface of middle coxae without pile. Pleura and coxae dark grey

tomentose, with a tinge of brownish.

Legs. Fore and middle femora without macrosetae; hind femora with 1 or 2 av at apex. Entire legs polished black, without tomentum. Pile on ventral surface of hind femora long, erect, black, the setae standing nearly at right angles to femoral axis, and as long as femoral width, on dorsal surface more whitish, also long and erect.

Wings dark grey hyaline, with blackish stigma and brown-black veins. Halteres black.

Abdomen. T2 and T3 with polished black anterior bands occupying slightly more than half tergal length, posterior parts white-grey tomentose. T4 almost entirely polished black, but with small posterolateral corners of white-grey tomentum. T5 and T6 with narrower, polished black anterior bands. Sternites greyish. Abdominal pile rather short and sparse, black on dark tergal areas, white on remainder.

Terminalia brown-black with blackish pile. Epandrium (Fig. 36) short relative to its width, with remarkably small, triangular cerci. S11 very wide. Gonocoxites broadly rounded posteriorly (Fig. 37), fused via a hyaline area; hypandrium triangular, showing narrow zones of fusion with gonocoxites, with a triangular window in middle, and bearing about 10 hair-like setae. Outer style slender-bodied, with extraordinarily distinct setae apically. Aedeagus (Fig. 38) of a generalised type.

Female. As for male except as follows. Eyes separated by 4.5x width of anterior ocellus. Frons in profile markedly protruding over entire length. Mesonotal tomentum with a more distinct brownish tinge.

Terminalia. S8 in face view (Fig. 208) remarkably wide posteriorly, with rather weak, unmodified, hair-like setae, in profile (Fig. 209) with a very low incurvation on posterior half. Third A1 seta about 6x as long as wide, blunt-tipped; 7 A1 setae per side. Longest A2 seta about twice as long as 3rd A1 seta; 7 or 8 A2 setae per side.

Dimensions. Body length 11–14 mm, wing 7.8–9.0 mm.

Type data. Holotype: male, FD, Tempest Spur, W. Olivine Range, 1219–1463 m, 29 January 1975, J.S. Dugdale (NZAC).

Paratypes: 1 male, 2 females, same data as holotype except one female labelled 30 January (NZAC).

Material examined. Type series only.

— / FD / —

Remarks. Polished black legs distinguish *A. atripes* from all other New Zealand *Anabarhynchus*. Its sister-species is undoubtedly *A. similis*; synapomorphic characters are the remarkably small cerci and lack of dorsocentral setae.

Anabarhynchus aureosericeus Kröber

Figures 42–44, 212, 213

aureosericeus Kröber, 1932: 136 (*Anabarrhynchus*). Lecto-type male, New Zealand.

Male. Head. Eyes separated in front of anterior ocellus by 3.5x its width. Frons slightly raised over entire length; setae black, weak, shorter than scape. Face bare. Head intensely golden yellow tomentose. Scape yellow-grey tomentose; flagellum blackish; terminal flagellar segments together about three-quarters as long as 1st segment. Occiput with about 40 macrosetae on either side, the dorsal ones black, the remainder yellowish. Pile on lower occiput and on genae golden yellowish. Palpi yellowish.

Thorax. Macrosetae: np 4, sa 2, pa 1, dc 1, sc 2; all setae black. Mesonotum with unpatterned, dull brown-grey tomentum; pile composed of erect black setae and appressed golden yellow setae, the latter dominating anteriorly, laterally, and posteriorly. Scutellum with long golden-yellow pile. Pleura and coxae grey-yellow tomentose. Prosternal furrow and sternopleura without pile; hind surface of middle coxae with a little pile.

Legs. Fore and middle femora without macrosetae; hind femora with 1 av and 1 pv at apex. Hind femoral pile nearly exclusively composed of golden-yellow hair-like setae; some very short black setae apparent on dorsal surface towards apex; length of pile on ventral surface half femoral width; semi-scaly pile apparent on dorsal surface. Femora and tibiae entirely yellow-brown.

Wings grey-brown hyaline; veins pale brownish; stigma indistinctly darkened. Halteres yellowish.

Abdomen grey to white-grey tomentose, with golden-yellow pilosity.

Terminalia yellow-brown with yellowish pile. Epandrium (Fig. 42) about 1.6x as wide as long; cerci three-quarters as long as epandrium. Gonocoxites (Fig. 43) forming a ventral synsclerite, with zones of fusion hardly recognisable; a minute, button-shaped sclerite, probably representing the hypandrium, enclosed in midline. Outer and inner styles unmodified; ventral lobe strongly modified, sickle-shaped, elongate, with a serrate inner margin. Aedeagus (Fig. 44) of a generalised type; sensorial field on proximal section of aedeagal apodeme well developed.

Female. As for male except as follows. Eyes separated by 5x width of anterior ocellus. Frontal pile weaker, sparser. Occipital macrosetae fewer, all yellowish. Entire body with a uniform golden yellow-brown tomentum, slightly greyish-tinged on pleura and sternites.

Terminalia. S8 in face view (Fig. 212) much reduced, so furca apparent both anteriorly and posteriorly, with lateral margins irregular and setae arranged in a bow, in profile as

in Fig. 213. Third A1 seta about 7x as long as wide, rather sharply pointed; 7 A1 setae per side. Longest A2 seta about twice as long as 3rd A1 seta; 5 or 6 A2 setae per side.

Dimensions. Body length 8.5–9.0 mm, wing about 7 mm.

Type data. Kröber described *Anabarrhynchus aureosericeus* on the basis of one male and one female. These syntypes (BMNH) are in reasonably good condition. Both are labelled "Te Wairoa / 15.xi.19" and carry Kröber's identification labels. I hereby designate the male as lectotype, and have labelled it accordingly.

Material examined. Lectotype and paralectotype (BP, Te Wairoa, J. Muggeridge), plus 2 non-type males, HB, Puketitiri, Little Bush, 10 Dec 1981 and 1 Apr 1982, T.H. & J.M. Davies (NZAC).

— / BP, HB / —

Remarks. This remarkable species has three obvious autapomorphic characters in the terminalia: (a) the male has an elongate, serrate ventral 'lobe' to the gonocoxite (Fig. 43); (b) the male has a ventral synsclerite incorporating a minute, button-shaped hypandrial element (Fig. 43); and (c) the female has S8 reduced (Fig. 212). The relationships are unclear, but *aureosericeus* could represent the derived sister-species to *A. femoralis*; they have nearly identical S8 setation in the female, and the male of *femoralis* has a moderately serrate ventral 'lobe' (Fig. 79).

Anabarrhynchus brevicornis new species

Figures 39–41, 216, 217

Male. Head. Eyes separated in front of anterior ocellus by 2.5–3.0x its width. Frons protruding in lower half, grey-brown to dark brown tomentose; pile black, very long, twice as long as scape. Face bare. A brownish fascia present at antennal level. Scape brown-black; 1st flagellar segment thick-bodied, about twice as long as combined length of terminal segments, its basal part red-brown; sub-basal setae of 1st flagellar segment remarkably strong. About 20 black occipital macrosetae on either side, the upper 3 or 4 slightly elongate, hair-like. Lower occiput and genae with long whitish pile. Palpi dirty yellowish.

Thorax. Macrosetae: np 3 or 4, sa 2, pa 1, dc 0 or 1, sc 2; dc and sc setae weak, hair-like, the former not always clearly distinguishable from the long black mesonotal pile. Disc of mesonotum brown-black, with 2 narrow, indistinct greyish stripes; humeri, notopleura, and supra-alar and postalar areas red-yellow to red-brown. Scutellum brown-black, with anterolateral corners red-yellow and posterior

margin grey; pile whitish. Pleura and coxae red-yellow to red-brown, with a thin cover of grey tomentum; lower part of sternopleura darkened. Prosternal furrow, sternopleura, and posterior surface of middle coxae without pile.

Legs. Fore femora with 1–3 av macrosetae at middle; middle femora without macrosetae or with a single pv at distal third; hind femora with 1 or 2 av and 1 or 2 pv at apex. Femora yellow-brown to chestnut-brown; dorsal surface of fore and middle femora extensively blackened, with a very thin white-grey tomentum. Hind femora with nearly exclusively blackish pile; some ventral setae longer than half femoral width; semi-sealy setae absent from dorsal surface. Tibiae dirty yellow-brown, darkened towards apex.

Wings very dark grey-brown; veins coarse, blackish, though Sc and basal section of R_1 more pale brownish; dark streaks present along veins; stigma brown-black; a hyaline area present in cell r, proximal to stigma. Halteres blackish.

Abdomen. T2–6 on disc with marked, shiny black bands reaching posterior tergal margin for a considerable distance, laterally yellow-brown to red-brown, partly with a thin whitish tomentum; sternites yellow-brown. Pile black on black tergal bands and on all of segments 5–7, whitish on remainder.

Terminalia brownish with a blackish pile. Epandrium as in Fig. 39. Gonocoxites (Fig. 40) simply rounded posteriorly, fused for a very short distance; hypandrial element wider than in *postocularis* (cf. Fig. 169), and outer style with a sharper apex. Aedeagus with phallic part (Fig. 41) curved for about 45° to longitudinal axis of aedeagus.

Female. As for male except as follows. Eyes separated by about 4x width of anterior ocellus. Femora appearing less blackened on dorsal surface.

Terminalia. S8 in face view as in Fig. 216; posterior half with a cup-shaped, demelanised, hardly depressed area provided with long, weak, anteriorly directed setae; setae forming pile on posterior lobe very thin; S8 in profile as in Fig. 217. Third A1 seta about 4x as long as wide, blunt-tipped; 6 A1 setae per side. Longest A2 seta about 3x as long as 3rd A1 seta; 7 or 8 A2 setae per side.

Dimensions. Body length 5.8–7.9 mm, wing 5.2–6.0 mm.

Type data. Holotype: male, MC, Banks Peninsula, Mt Evans, October 1962, P.M. Johns (LCNZ).

Paratypes: 6 males, 5 females, same data as holotype (LCNZ, NZAC, ZMKD).

Material examined. Type series only.

— / MC / —

Remarks. *A. brevicornis* is probably the sister-species to

A. postocularis. Both are characterised by small size (less than 8 mm in total length), a tendency to formation of elongate, forward-directed postocular setae (not otherwise seen in New Zealand *Anabarhynchus*), and extensive yellowish coloration of the pleura, coxae, and lateral parts of the tergites.

Anabarhynchus bruninervis Kröber

Figures 45–47, 58, 210, 211

bruninervis Kröber, 1932: 128 (*Anabarrhynchus*). Holotype female, New Zealand.

Male. Head. Eyes separated in front of anterior ocellus by about twice its width. Frons very slightly protruding in lower part; pile black or black and white, shorter than scape; tomentum grey to grey-brown. Face with a few short, pale setae. Scape grey-black; flagellum blackish; terminal flagellar segments together about half as long as 1st segment. Occiput with 35–40 strong macrosetae on either side, all black or lower ones demelanised. Pile of lower occiput and genae whitish. Palpi grey-brown.

Thorax. Macrosetae: np 4, sa 2, pa 1, dc 1 or 2, sc 2; all setae black, strong. Disc of mesonotum with 3 broad dark brown bands separated by narrow pale grey to yellow-grey stripes; mesonotum ash-grey tomentose anteriorly and laterally; pile rather short, composed of both black and white-yellow setae. Scutellum uniformly pale grey; pile white-yellow. Pleura and coxae ash-grey tomentose; pile whitish. Prosternal furrow and sternopleura without pile; posterior surface of middle coxae with some pile.

Legs. Fore femora with 2–4 av macrosetae and 4 or 5 pd; middle femora with 1 av and 2–4 pv; hind femora with 2 or 3 av and 1 pv. Femora and tibiae grey-black, knees brownish. Pile of hind femora uniformly whitish, semi-appressed to appressed, not semi-scaly.

Wings grey-brown hyaline, with distinct dark brownish streaks along veins, widest in proximal half of wing, thus 1st basal cell wholly brownish; veins brown-black; stigma not distinguishable from brownish streaks. Halteres brown-black, darkest around base of knob.

Abdomen whitish-grey tomentose; pile whitish.

Terminalia grey-black; pile mostly whitish. Epandrium (Fig. 45) with cerci characteristically egg-shaped in outline. Gonocoxites (Fig. 46, 58) with a broad, blunt-tipped posterior extension, fused together for a short distance; hypandrium rather discrete. Outer and inner styles strong, the latter with a dorso-exterior lobe. Aedeagus (Fig. 47) with a dorsal 'hood' covering proximal part of phallic tube; ventral aedeagal apodeme angularly bent.

Female. As for male except as follows. Eyes separated by

4.5–5.0x width of anterior ocellus. Frons brownish tomentose, paler grey-brown below, with a pair of darker brown spots on middle. Mesonotum much paler, uniformly grey-brown tomentose. Middle femora with an additional weak pd seta. T2–4 with distinct brown-black anterior bands, leaving posterior margins narrowly white-grey tomentose on T2 and T3, and more widely so on T4; lateral areas white-grey tomentose.

Terminalia. S8 in face view (Fig. 210) wide, in profile (Fig. 211) with a very slight incurvation around middle; pile sparse, composed of long, simple setae. Third A1 seta about 5x as long as wide, blunt-tipped; 7 A1 setae per side. Longest A2 seta about as long as 3rd A1 seta; 6 or 7 A2 setae per side.

Dimensions. Total length 10–11 mm, wing 7.7–7.9 mm.

Type data. Kröber described *A. bruninervis* on the basis of a single female. The holotype (BMNH) is in reasonably good condition and bears, among others, a label "Oh. 2/20", agreeing with the information given in the description: "Ohakume [sic] II.20 (J. Muggeridge leg.)."

Material examined. Holotype (RI, Ohakune) plus 4 non-type examples; 1 male, ND, Waipoua, coastal scrub and dunes, 13 Oct 1967, J.S. Dugdale (NZAC); 1 male, TO, Taupo, 28 Nov 1931, J.S. Armstrong (NZAC); 1 female, TO, Taupo, garden, 24 Dec 1922, ? coll. (NZAC); 1 male, RI, Ohakune, Jan 1912, G.V. Hudson (BMNH).

— / ND, TO, RI / —

Remarks. *A. bruninervis* and *A. spiniger* have a strong synapomorphy in the dorsal 'hood' to the phallic part of the aedeagus. A larger, probably monophyletic group is formed by *bruninervis*, *spiniger*, *indistinctus*, and *ostentatus* (possibly also *stuvaitilis*); they are characterised by a posterior extension of the gonocoxite and a strongly developed inner style bearing a rounded dorsal lobe.

Anabarhynchus caesius Kröber

Figures 48–50, 214, 215

caesius Kröber, 1912: 219 (*Anabarrhynchus*). Holotype male, New Zealand.

Male. Head. Eyes separated in front of anterior ocellus by 3x its width. Frons suddenly and markedly raised from just below ocellus, grey-brown tomentose; pile black; longest setae as long as scape. Face bare. Scape grey-black; flagellum black; terminal flagellar segments together slightly longer than half length of 1st segment. Occiput with over 50 strong black macrosetae on either side. Pile of lower

occiput and genae white-yellow. Palpi slightly dilated towards apex, yellow, becoming greyish apically.

Thorax. Macrosetae: np 4, sa 2, pa 1, dc 2, sc 2; all setae black. Mesonotum brownish grey tomentose, with 5 dark brown longitudinal stripes — a very narrow median stripe, and 2 pairs of slightly wider lateral stripes, interrupted at notopleural furrow. Scutellum extensively brown-black on disc. Mesonotal and scutellar pile moderately long, black; additional long, pale hair-like setae along posterior margin of scutellum. Prosternal furrow, sternopleura, and posterior surface of middle coxae without pile. Pleura and coxae uniformly white-grey tomentose.

Legs. Fore and middle femora without macrosetae or with 1 av; hind femora with 1 or 2 av and 1 pv. Femora red-brown, darker towards apices, and darker dorsally than on ventral surface. Pile of hind femora composed of white-yellow and blackish hair-like setae, the latter dominating in distal half and dorsally; white, semi-scaly pile on dorsal surface; length of ventral pile at base nearly half femoral width. Tibiae concolorous with femora, not markedly darker towards apices.

Wings with a characteristic pattern: costa to outrun of R_{2+3} and subcosta yellowish, other veins brownish black; ground colour brownish, but basal areas of subcostal and 1st radial cells whitish hyaline, strongly contrasting with brown-black stigma. Halteres yellowish, darkened dorsally and around base of knob.

Abdomen. T2–5 with large, ill marked, dull grey-black areas, nearly reaching posterior tergal margins in strict dorsal view, leaving posterolateral areas of all tergites gradually more ash-grey tomentose; in lateral view tergites and sternites appearing ash-grey tomentose. Pile short, rather sparse, black on darkened tergal areas, white elsewhere.

Terminalia. Epandrium and gonocoxites blackened; cerci red-yellow. Epandrium (Fig. 48) about 1.3x as wide as long; pile black, restricted; cerci coarse, button-shaped, nearly as long as epandrium. Gonocoxites (Fig. 49) fused for a short distance; hypandrium large, rather discrete, with wide, dark zones of fusion with gonocoxites. Outer style with a sharp subapical tooth and a few minute setae at apex; inner style with dorsal margin straight (when viewed laterally). Aedeagus (Fig. 50) of a generalised type.

Female. As for male except as follows. Eyes separated by 3.5x width of anterior ocellus. Frontal pile shorter than scape. Thorax sometimes with up to 5 or 6 np macrosetae on either side. Mesonotal and scutellar pile shorter. Fore and middle femora without macrosetae; hind femora with 1 av macroseta and 1 pv. Ventral pile of hind femora shorter than one-fourth of femoral width. Tergal bands more distinctly delimited from grey tomentose areas by their darker brown-black colour; pile shorter.

Terminalia. S8 in face view (Fig. 214) moderately setose, in profile as in Fig. 215. Third A1 seta about 6x as long as wide, blunt-tipped; 6 A1 setae per side. Longest A2 seta about twice as long as 3rd A1 seta; 6 or 7 A2 setae per side.

Dimensions. Body length 9.5–10.4 mm, wing 9.0–10.6 mm.

Type data. Kröber described *caesius* from a single male specimen from "Neuseeland" collected February 1882. The holotype (NHMW) is labelled "N. Sceld./1882.II", "Type", and "Anabarhynchus caesius Kröber /det. Kröber 1911". It is in reasonably good condition, although the right foreleg and both middle legs are missing.

Material examined. Holotype, plus 5 non-type examples: 4 females, BR, Punakaiki Scen. Res., Bullock Ck, 20 m, 8–17 Feb 1983, Malaise trap, G.R. Champness (LCNZ); 1 male, WD, Westland N.P. adj. Canavan's Knob, 140 m, Feb–Mar 1982, Malaise trap, A.B. Miller (LCNZ).

— / BR, WD / —

Anabarhynchus completus new species

Figures 51–53, 218, 219

Male. Head. Eyes separated in front of anterior ocellus by about 3.5x its width. Frons grey-brown tomentose, slightly protruding in lower part; pile black; longest setae as long as scape. Face bare. Scape greyish; flagellum blackish; terminal flagellar segments together 0.6x as long as 1st segment. Occiput with 45–50 strong black macrosetae on either side. Lower occiput and genae with whitish pile. Palpi grey-brown.

Thorax. Macrosetae: np 4 or 5, sa 2, pa 1, dc 2, sc 2; setae strong, black. Mesonotum uniformly greyish tomentose; pile nearly exclusively blackish; scutellum greyish with whitish pile. Prosternal furrow, sternopleura, and posterior surface of middle coxae without pile. Pleura and coxae greyish tomentose.

Legs. Fore femora with 2 pd macrosetae, 2 av, and 1 small pv; middle femora with 1 or 2 pv; hind femora with 1 or 2 av, sometimes also 1 pv. Femora and tibiae grey-black. Pile of hind femora whitish, uniform, appressed to semi-appressed.

Wings white-grey hyaline, unpatterned; veins and stigma pale brown; dorsal surface of R_1 with minute setae over entire length, i.e., from fork with other radial veins. Halteres brown-black.

Abdomen. Tergites and sternites indefinitely grey-brown-black, slightly darker anteriorly than posteriorly but not distinctly banded; pile composed of black and white setae.

Terminalia brownish; pile whitish and blackish. Epan-drium (Fig. 51) about 1.5x as wide as long; cerci short, broad. Gonocoxites (Fig. 52) pointed, characteristically divergent, forming a synsclerite anteriorly; hypandrial element not discernible. Outer style appearing short and wide basally, relative to inner style. Aedeagus as in Fig. 53.

Female. As for male except as follows. Eyes separated by 4.5x width of anterior ocellus. Frons protruding over entire length. Veins blackish. Tergites greyish tomentose except for yellowish-grey tomentose lateral areas of T2+3.

Terminalia. S8 in face view (Fig. 218) with a paired incision into posterior margin, in profile (Fig. 219) with a very deep incision around middle due principally to the very protruding posterior lobe. Lateral parts of posterior lobe with long pile directed anterolaterally to posterolaterally, overlying anteromedially directed pile of sclerite 'below'. Third A1 seta about 6x as long as wide, blunt-tipped; 8 A1 setae per side. Longest A2 seta about 1.5x as long as 3rd A1 seta; 8 or 9 A2 setae per side.

Dimensions. Total length 9–10 mm, wing 7.1–7.4 mm.

Type data. Holotype: male, KA, Puketa, beach area, 18 November 1977, E.I. Schlinger (NZAC).

Paratypes: 1 male, 5 females, same data as holotype (CISB, NZAC, ZMKD).

Material examined. Type series, plus 9 non-type males, MC, Christchurch, Brighton, sand dunes, 18 Dec 1974 and 8 Feb 1975, R.P. Macfarlane (NZAC); see Remarks below and under *A. arenarius*.

— / KA, MC / —

Remarks. *A. completus* belongs in the *nebulosus*-group and is unique among these species in having minute setae over the entire length of R₁ together with unpatterned wings; see also Remarks under *A. nebulosus*.

The males from Brighton differ slightly from the type series. The eyes are separated by about 3x the width of the anterior ocellus; the mesonotum is indistinctly striped with brown-grey tomentum; the mesonotal pile is composed of both black and pale setae; and the tergites are entirely greyish tomentose, with exclusively whitish pile. There are no essential differences in the male terminalia, however.

***Anabarhynchus curvistylus* new species**

Figures 54–57, 222, 223

Male. Head. Eyes separated in front of anterior ocellus by 2.0–2.2x its width. Frons moderately protruding in lower

part, grey, yellow-grey, or white-grey tomentose; pile either entirely pale or with at least some pale setae on lower frons; setae shorter than scape. Face bare. Scape greyish; flagellum blackish; terminal flagellar segments together about 0.7x as long as 1st segment. Occiput with over 60 macrosetae on either side, sometimes all black but usually upper ones black and remainder demelanised. Pile of lower occiput and genae whitish yellow. Palpi dirty yellowish.

Thorax. Macrosetae: np 4–6, sa 2, pa 1, dc 2, sc 2; all setae black. Mesonotum grey to white-grey tomentose, with 3 dark brownish tomentose stripes; pile moderately long, composed of black and whitish or yellowish hair-like setae. Scutellum grey; pile long, whitish. Prosternal furrow and sternopleura without pile; posterior surface of middle coxae with some whitish pile. Pleura and coxae whitish-grey tomentose.

Legs. Fore femora without macrosetae, or with 1 strong av at middle, and frequently also 1 or 2 weaker av; middle femora without macrosetae, or with 1 or 2 av and pv; hind femora with 2–4 av and 1 pv; one or more macrosetae sometimes demelanised. Femora grey-black, with extreme apices yellow-brown. Pile on ventral surface of hind femora composed of semi-erect, whitish setae up to half as long as femoral width; pile on dorsal surface appressed, semi-scaly. Tibiae yellow-brown, slightly darkened at apices.

Wings grey-brown hyaline; stigma and veins dark brownish. Halteres brown-black.

Abdomen white-grey tomentose, with whitish pile.

Terminalia coloured as remainder of abdomen. Epan-drium (Fig. 54) shorter in midline than wide; cerci broad, nearly as long as epan-drium. Gonocoxites in external ventral view characteristically approximated for a long distance, posteriorly with a bare, polished black area, and terminating in a demelanised apex; no hypandrial element discernible (Fig. 55). Outer style (Fig. 56) heavily built, elbow-shaped, usually easily observable without dissection. Aedeagus (Fig. 57) with phallic part only slightly curved, gradually tapering to sharp apex.

Female. As for male except as follows. Eyes separated by about 3.4x width of anterior ocellus. Frons protruding over entire length; pile shorter, yellowish. Occipital macrosetae fewer, shorter, weaker, often only a few upper ones black, remainder pale. Abdomen greyish tomentose, with whitish appressed pile on T2–3 and blackish erect pile on T4–7.

Terminalia. S8 in face view (Fig. 222) irregularly squar-ish, with posterior half demelanised, less so on middle third, in profile (Fig. 223) with a postmedian incurvation. Pile short, rather weak. Third A1 seta about 9x as long as wide, sharp-tipped; 8 or 9 A1 setae per side. Longest A2 seta about as long as 3rd A1 seta; 6 or 7 A2 setae per side, all demelanised.

Dimensions. Body length 11–12 mm, wing 9.1–10.2 mm.

Type data. Holotype: male, NN, Abel Tasman N.P., Totaranui Bay, beach area, 25 November 1977, E.I. Schlinger (NZAC).

Paratypes: 2 males, WI, Wanganui Beach, 28 October 1968, J.S. Dugdale (NZAC); 1 male, WI, camp S of Turakina Beach, 9 November 1977, E.I. Schlinger (CISB); 1 male, WN, Waikanae Beach, 17 February 1977, G.W. Gibbs (ZMKD); 3 males, 3 females, NN, same data as holotype (CISB); 1 male, 1 female, BR, Charleston, Nile River, 26 November 1977, E.I. Schlinger (CISB); 1 female, WD, Ship Creek N of Haast, 8 December 1977, E.I. Schlinger (CISB).

Material examined. Type series only.

— / WI, WN / NN, BR, WD / —

Remarks. The relationships of *A. curvistylus* are unclear, though the very coarse, enlarged cerci may represent a synapomorphy with *A. rufobasalis* (cf. Fig. 174). The male is easily recognised by the enlarged, elbow-shaped outer style and a peculiar approximation of the gonocoxites (see description and figures). As with other species frequenting beach areas, it shows tendencies towards demelanisation of the frontal pile and macrosetae of occiput and legs.

Anabarhynchus diversicolor new species

Figures 60–62, 220, 221

Male. Head. Eyes separated in front of anterior ocellus by about twice its width. Frons markedly protruding from just below anterior ocellus, yellow-brown-grey tomentose (as on mesonotum); pile black; some setae as long as scape. Face bare. Scape grey-black; flagellum blackish; terminal flagellar segments together about half as long as 1st segment. Occiput with about 45 strong black macrosetae on either side. Pile of lower occiput and genae whitish. Palpi yellowish.

Thorax. Macrosetae: np 4 or 5, sa 2, pa 1, dc 2, sc 2; setae black. Mesonotal tomentum cinnamon-brown, unpatterned; similar tomentum covering dorsal part of mesopleuron; remainder of pleura and entire coxae white-grey tomentose, strongly contrasting with mesonotal tomentum. Mesonotal pile relatively long, composed mainly of brownish setae; a few black setae intermixed around middle. Scutellum with tomentum and pile as on mesonotum. Prosternal furrow, sternopleura, and posterior surface of middle coxae without pile.

Legs. Fore femora with 1 av macroseta; middle femora without macrosetae; hind femora with 1 or 2 av and 1 pv.

Femora and tibiae yellow-brown. Pile on hind femora composed mainly of yellowish setae, but short, black setae intermixed dorsally; pile on dorsal surface semi-scaly and appressed, on ventral surface normal and semi-appressed; length of pile about one-quarter of femoral width.

Wings grey-brown, darkest in broad streaks along veins; stigma and veins dark brownish. Halteres yellow.

Abdomen. Tergites dull grey-black in dorsocaudal view, white-grey tomentose in dorsofrontal view; lateral parts red-yellow; pile long, whitish. Sternites red-yellow, with slight white-grey tomentum and long whitish pile.

Terminalia red-yellow with pale pilosity. Epandrium (Fig. 60) wider than long; cerci about half as long as epandrium. Gonocoxites (Fig. 61) with well marked zones of fusion with each other and with hypandrium. Outer style with a subapical tooth similar to apical tooth. Aedeagus (Fig. 62) with phallic part of even width for a long distance, then terminating in a very short, narrow apex.

Female. As for male except as follows. Eyes separated by 3.2x width of anterior ocellus. Frontal pile a little shorter, and frontal tomentum dark brownish, darker than in male. Occiput with only about 35 macrosetae on either side. Thoracic macrosetae: 4 np on either side. Mesonotum with same dark brownish tomentum as on frons, strongly contrasting with greyish pleura. Femora a little brownish dorsally at apex. Tergites dull brown-black on disc, not clearly red-yellow laterally but with yellow-grey tomentum. Pile whitish yellow on T2–4, blackish on T5–7.

Terminalia. S8 in face view (Fig. 220) rather ovoid, in profile (Fig. 221) with a low postmedian incurvation; pile short, rather restricted. Third A1 seta about 5x as long as wide, blunt-tipped to slightly spatulate; 8 A1 setae per side. Longest A2 seta about twice as long as 3rd A1 seta; 7 A2 setae per side.

Dimensions. Body length about 8.0 mm, wing about 7.5 mm.

Type data. Holotype: male, BR, Punakaiki, 30 October 1970, Ento. Dept. Field Trip (LCNZ).

Paratypes: 1 female, same data as holotype (LCNZ).

Material examined. Type specimens only.

— / BR / —

Remarks. *A. diversicolor* is probably closely related to *A. flaviventris*. Both have yellow-brown legs, and the phallic part of the aedeagus is of even width and nearly straight for a long distance.

Anabarrhynchus dugdalei new species

Figures 66–68, 224, 225

Male. Head. Eyes separated in front of anterior ocellus by about 5x its width. Frons dark grey tomentose, protruding over entire length; pile black, erect; setae longer than scape. Face with long setae laterally. Scape grey-black; flagellum blackish; terminal flagellar segments together slightly less than half as long as 1st segment. Occiput with about 30 strong black macrosetae on either side. Pile on lower occiput and genae whitish. Palpi grey-brown.

Thorax. Macrosetae: np 5 or 6, sa 3, pa 1, dc 2, sc 4; all setae black. Mesonotum uniformly dark greyish tomentose; pile moderately long, black, erect. Scutellum grey-black; pile mainly blackish. Prosternal furrow and sternopleura without pile; posterior surface of middle coxae with some pile. Pleura and coxae greyish tomentose.

Legs. Fore femora with 2 av macrosetae; middle femora without macrosetae; hind femora with 3 or 4 av and 1 or 2 weak pv. Femora grey-black; tibiae brownish. Pile on ventral surface of hind femora whitish, as long as femoral width; pile on dorsal surface whitish, not scaly.

Wings grey-brown hyaline, darker brown-black along veins and on stigma. Halteres brown-black.

Abdomen appearing dull grey-black owing to discoloration; pile composed of both whitish and blackish setae.

Terminalia blackish; pile black. Epandrium (Fig. 66) twice as wide as long; cerci short, wide. Gonocoxites (Fig. 67) broadly rounded posteriorly, fused via a semi-hyaline area for a short distance posteriorly; hypandrial element rather discrete, with some setae. Outer style rather blunt-tipped, with a few relatively long setae apically. Aedeagus (Fig. 68) heavily built; phallic part thick-bodied, with apex short, upcurved.

Female. As for male except as follows. Frontal tomentum with a brownish tinge. Thoracic macrosetae: np 3–5, sa 2 or 3, pa 1 or 2, dc 1 or 2, sc 3 or 4. Mesonotal tomentum brownish-tinged laterally. Scutellum with whitish pile along posterior margin. Fore femora without macrosetae or with 1 av. Tergites uniformly grey-black. Pile on disc of T2–4 appressed, black, on lateral areas whitish and more erect. Pile on T5–7 coarse, stiff, black. Sternites greyish, with whitish pile on S2–4, blackish pile on S5–7.

Terminalia. S8 in face view (Fig. 224) widest around middle, with a deep demelanised area, in profile (Fig. 225) with a deep incurvation at middle third; pile coarse, partly posteriorly directed. Third A1 seta about 5.5x as long as wide, blunt-tipped; 8 A1 setae per side. Longest A2 seta about 1.6x as long as 3rd A1 seta; 7 or 8 A2 setae per side.

Dimensions. Body length 13–15 mm, wing 10.4–11.6

mm.

Type data. Holotype: male, NN, Iron Hill, 1361–1676 m, 18 November 1972, K.J. Fox & J.S. Dugdale (NZAC).

Paratypes: 1 female, MB, Black Birch Range, Altimarlack, 1432–1554 m, 15 January 1973, J.S. Dugdale (NZAC); 1 female, OL, Lake Luna, 2600' [780 m], 21 December 1919 (NZAC); 1 female, OL, Tooth Peaks, 1500' [450 m], 24 December (1918 or 1919), ? coll. (NZAC).

Material examined. Type series only.

— / NN, MB, OL / —

Anabarrhynchus dysmachiiformis Kröber

Figures 69–71, 226, 227

dysmachiiformis Kröber, 1932: 129 (*Anabarrhynchus*).

Lectotype male, New Zealand.

Male. Head. Eyes separated in front of anterior ocellus by 2.2–2.5x its width. Frons moderately protruding in lower half, brown-grey to greyish tomentose; pile black; most setae shorter than scape. Face bare. Scape grey-black; flagellum blackish; terminal flagellar segments together about half as long as 1st segment. Occiput with over 60 strong black macrosetae on either side. Pile of lower occiput and genae whitish. Palpi yellowish brown.

Thorax. Macrosetae: np 5 or 6, sa 2 or 3, pa 1, dc 2, sc 2; all setae strong, black. Mesonotum slightly hump-backed, with a very distinct pattern formed by 3 brown-black bands on pale yellow-grey tomentose ground colour. Mesonotal pile short and black on disc, with longer, paler setae intermixed laterally and posteriorly. Scutellum brown-black on disc, with posterior margin yellow-grey tomentose; pile moderately long, whitish, bushy; mainly black setae on brown-black disc. Prosternal furrow, sternopleura, and posterior surface of middle coxae without pile. Pleura and coxae greyish.

Legs. Fore femora with 1–3 strong av macrosetae, frequently also some weak pv at apex; middle femora with 1–3 pv; hind femora with 1–3 av and 1 or 2 pv. Femora blackish, only slightly tomentose. Pile on ventral surface of hind femora long, semi-erect, whitish, the hair-like setae sometimes longer than half femoral width; pile on dorsal surface semi-scaly, appressed, whitish, at apex mainly black. Fore tibiae blackish; middle tibiae brownish with distal one-fourth or so blackish; hind tibiae brown-black in proximal half to two-thirds, blackish distally.

Wings grey-brown hyaline, with streaks along veins slightly more intensely coloured; stigma and veins dark brown to brown-black. Halteres yellowish, darkened around base of knob and on stem.

Abdomen. T2–7 blackish on disc, greyish tomentose posterolaterally (lectotype a little brownish translucent on T2 and T3). Pile black and appressed on blackish areas, whitish and more erect on greyish areas. Sternites greyish, with a broad darker median stripe; pile white-yellow.

Terminalia blackish with black pile. Epandrium (Fig. 69) wider than long, with dense cover of short setae; cerci large, moderately sharply pointed. Gonocoxites (Fig. 70) with wide zones of fusion with hypandrial element. Outer style remarkably stout, with sharp apex and a lamellate subapical tooth. Aedeagus (Fig. 71) of a generalised type.

Female. As for male except as follows. Eyes separated by 3.5–3.8x width of anterior ocellus, with a more or less distinct inverted V-shaped brownish mark on middle; upper part pure greyish tomentose, lower part more yellow-grey tomentose. T2–6 subshiny to shiny brown-black on dorsum, pale grey tomentose laterally; line of demarcation more or less parallel to longitudinal axis of abdomen. T7 polished black. Abdominal pile black and appressed on blackish parts of T2–4 but whitish laterally, on T5 long and black, and on T6 and T7 shorter, black, and more erect. Sternites grey-yellow with a darker middle band.

Terminalia. S8 in face view (Fig. 226) with a circular depression at middle, in profile (Fig. 227) with a premedian incurvation; pilosity restricted in distribution, composed of strong setae, also on posterior lobe. Third A1 seta 5–6x as long as wide, blunt-tipped; 8 A1 setae per side. Longest A2 seta about 3x as long as 3rd A1 seta; 6 A2 setae per side.

Dimensions. Body length 10–13 mm, wing 8.5–9.8 mm.

Type data. Kröber (1932, p.129) described *dismachiiiformis* from two syntypes, a male and a female; both are deposited in the BMNH and are well preserved. The male is labelled "New Zealand / J. Muggeridge" and "Anabarhynchus dismachiiiformis [sic] Krb./det. Kröber 1931", and is hereby designated as lectotype. The female is labelled "Oh 2/30" (probably Ohakune, RI), "New Zealand / J. Muggeridge", and "Anabarhynchus dismachiiiformis [sic] Krb. / det. Kröber 1931"; I have labelled this as a paralectotype. Both syntypes are probably topotypic, collected on the same date at Ohakune.

Material examined. Type specimens, plus 8 non-type examples: 1 male, WO, Ruakura, 21 Jan 1960, G. Cairns (NZAC); 1 female, BP, Tauranga, 14 Jan 1950, G.W. Ramsay (NMNZ); 1 male, TO, Taupo, 22 Jan 1957, J.S. Armstrong (NZAC); 1 male, TO, Taupo, Aratiatia rapids, 14 Feb 1943, J.S. Armstrong (NZAC); 1 male, TO, National Park, 22 Feb 1947, ? coll. (NZAC); 1 male, WN, Waitarere, Levin, 16 Apr 1960, R.G. Ordish (NMNZ); 1

male, NN, Abel Tasman N.P., 4 Feb 1981, J.B. Waller (LCNZ); 1 female, BR, Nelson Lakes N.P., L. Rototoi Lodge, 31 Jan – 3 Feb 1972, R. Welsh (LCNZ).

— / WO, BP, TO, RI, WN / NN, BR / —

Remarks. *A. dismachiiiformis* is easily recognised by its very well marked mesonotal stripes and slightly hump-backed mesonotum; the outer style is very heavy. Its relationships are uncertain.

Anabarhynchus emersoni new species

Figures 72–74, 228, 229

Male. Head. Eyes separated in front of anterior ocellus by 4x its width. Frons moderately protruding over entire length, golden grey-brown tomentose; pile black; setae about as long as scape. Face bare. Scape greyish; (remainder of antennae missing in holotype). Occiput with about 30 strong black macrosetae on either side. Pile of lower occiput and genae pale yellow. Palpi yellowish.

Thorax. Macrosetae: np 4, sa 2, pa 1, dc 2, sc 2; all setae strong, black. Mesonotum practically uniformly grey-black; pile moderately long, composed of erect black setae and more appressed yellowish setae. Scutellum greyish with yellowish pile. Prosternal furrow and sternopleura without pile; posterior surface of middle coxae with some pile. Pleura and coxae greyish.

Legs. Fore femora with 2 av macrosetae; middle femora with 0 or 1 av and 1–3 pv; hind femora with 1 av and 1 pv. Femora blackish, only thinly tomentose. Pile on ventral surface of hind femora very short, yellowish, on dorsal surface comprising semi-scaly, appressed, yellow-white setae and erect, short, black setae. Fore tibiae blackish, indistinctly brownish basally; middle and hind tibiae brownish, with distal third of middle tibiae and distal half of hind tibiae more blackish but not sharply demarcated.

Wings grey-brown hyaline, with pale brownish stigma and brown to brown-black veins. Halteres yellowish, with apex and base of knob brownish.

Abdomen entirely discoloured in holotype (see description of female).

Terminalia. Epandrium (Fig. 72) slightly narrower than long; cerci long, pointed. Gonocoxites (Fig. 73) with very marked zones of fusion with each other and with hypandrium. Outer style long, slender, with a sharp tooth at a distance from apex. Aedeagus (Fig. 74) of a generalised type.

Female. As for male except as follows. Eyes separated by 4.6x width of anterior ocellus. Frons more protruding. Occiput with about 20 macrosetae on either side. Mesonotum with indistinct traces of 2 brownish stripes. Abdo-

men practically uniformly grey-black tomentose; pile of T2–4 composed of both yellowish and blackish setae, but from T5 onwards only black. Sternites greyish with yellowish pile.

Terminalia. S8 in face view (Fig. 228) with 2 oval, slightly depressed demelanised areas, in profile (Fig. 229) with a very slight incurvation at middle; pile rich, arranged as in Fig. 228. Third A1 seta about 5X as long as wide, broadly blunt-tipped to slightly spatulate; 7 A1 setae per side. Longest A2 seta about 2.3X as long as 3rd A1 seta; 7 A2 setae per side.

Dimensions. Body length 10–12 mm, wing 9.5 mm.

Type data. Holotype: male, NC, Craigieburn, Mt Wall, 3500' [1050m], 25 January 1972, R.M. Emberson (LCNZ).

Paratypes: 1 female, same data as holotype (LCNZ).

Material examined. Type specimens only.

— / NC / —

Remarks. *A. embersoni* is probably closely related to *A. gibbsi*. Both have elongate, sharp-tipped cerci, elongate outer and inner styles, and the female S8 with a doubled demelanised structure.

Anabarhynchus exiguus Hutton

Figures 63–65, 230, 231

exiguus Hutton, 1901: 26 (*Anabarhynchus*). Lectotype male, New Zealand.

novazealandiae Kröber, 1932: 140 (*Neothereva*). Lectotype male, New Zealand.

Male. Head. Eyes separated in front of anterior ocellus by 3.0–3.5X its width. Frons protruding in lower half, yellow-brown tomentose; pile black; setae as long as scape. Face bare. Scape grey-brown; flagellum blackish, with proximal third of 1st segment yellowish; terminal flagellar segments together about half as long as 1st segment. Occiput with about 35–40 demelanised, rather short but strong macrosetae on either side. Lower occiput and genae with whitish pile. Palpi yellowish.

Thorax. Macrosetae: np 4, sa 2, pa 1, dc 2, sc 2; all setae black, rather strong. Mesonotum and scutellum grey-brown tomentose, with traces of 3 narrow darker stripes; pile rather long, composed of both pale and black setae. Pleura greyish to grey-brown; coxae yellow-brown, with slight greyish tomentum basally. Prosternal furrow, sternopleura, and posterior surface of middle coxae without pile.

Legs. Fore femora with 1 pd macroseta, 1 or 2 av, and 2 to several pv; middle femora with several pv; hind femora

with 1–4 av and 1 or 2 pv. Legs yellowish. Pile of hind femora uniformly yellowish, semi-croct to rather appressed.

Wings grey-brown hyaline; veins pale yellow in basal and anterior parts, blackish in posterior part; stigma pale yellow. Halteres yellow.

Abdomen. Tergites uniformly white-grey tomentose; pile whitish. Sternites more brownish.

Terminalia brownish with mainly whitish pile. Epanthrium (Fig. 63) narrower than long, its pile long and rich; cerci slightly elongate. Gonocoxites (Fig. 64) with a long, narrow zone of fusion; hypandrial element minute. Outer style with a weak preapical tooth. Aedeagus (Fig. 65) of a generalised type.

Female. As for male except as follows. Eyes separated by about 5X width of anterior ocellus. T2–4 grey-black, with only slight tomentum; remaining tergites becoming increasingly yellow-brown posterad; pile black from T4 onwards.

Terminalia. S8 in face view (Fig. 230) ovoid, with a deep incision into anterior margin, in profile (Fig. 231) with a slight postmedian incurvation; pile very restricted. Third A1 seta about 5X as long as wide, blunt-tipped; 8 A1 setae per side. Longest A2 seta about twice as long as 3rd A1 seta; 8 A2 setae per side.

Dimensions. Total length 7–9 mm, wing 5.5–5.8 mm.

Type data. Hutton described *A. exiguus* from a pair taken at Christchurch, MC. Both syntypes (CMNZ) are in good condition. The male (labelled "Type") is hereby designated as the lectotype, and has been labelled accordingly. The female, labelled "Paratype", has been labelled as paralectotype.

The syntypic series of *Neothereva novazealandiae* (BMNH) comprises a male and a female from Christchurch. The male is hereby designated as the lectotype.

Material examined. Type specimens, plus 4 non-type examples: 1 male, MC, Banks Peninsula, Birdlings Flat, 7 Jan 1976, J.K. Barnes (NZAC); 1 female, no data, Wakefield Coll. (CMNZ); 1 male, 1 female, CO, Clutha R. bank 4 km E of Clyde, 6 Dec 1977, E.J. Schlinger (CISB).

— / MC, CO / —

Anabarhynchus farinosus new species

Figures 75–77, 232, 233

Male. Head. Eyes separated in front of anterior ocellus by twice its width. Frons moderately raised in lower half, grey (above) to white-grey (below) tomentose; pile composed

of black and whitish setae, the latter predominating on lower part; longest frontal setae as long as scape. Face bare. Scape grey-black; flagellum black; terminal flagellar segments together half as long as 1st segment. Occiput with more than 50 strong, black macrosetae on either side. Pile of lower occiput and genae whitish. Palpi slightly dilated towards apex, yellowish.

Thorax. Macrosetae: np 5, sa 2, pa 1, dc 1, sc 2; all setae black. Mesonotum indistinctly banded in white-grey and darker grey tomentum, the latter forming a medial band occupying nearly one-third of mesonotal width, and with a narrow, dark brown median stripe; also a pair of darker streaks on the dark grey lateral bands. Scutellum grey, with a small brownish spot at middle. Mesonotal and scutellar pile rather long, composed of whitish and blackish hair-like setae. Prosternal furrow, sternopleura, and posterior surface of middle coxae without pile. Pleura and coxae uniformly white-grey tomentose.

Legs. Fore femora with 1 strong av macroseta; middle femora without macrosetae; hind femora with 1 or 2 av and 1 pv. Femora yellowish; fore femora extensively grey-black on posterodorsal surface, except for extreme base. Pile of hind femora composed of white and black hair-like setae, the latter short and very sparsely distributed. White, semi-scaly setae present on dorsal surface; length of pile on ventral surface half femoral width. Tibiae yellow, not darkened at apices.

Wings whitish hyaline; veins brownish to dark brownish; stigma indistinctly marked. Halteres with knob pale yellowish.

Abdomen. Tergites and sternites white-grey tomentose; pile whitish.

Terminalia yellowish; pile whitish. Epandrium (Fig. 75) wider than long; pile very short and sparse; cerci less than half as long as epandrium. Gonocoxites (Fig. 76) forming dark fusion zones, posteriorly with each other, anteriorly with hypandrium. Outer style remarkably slender towards apex, with a weak subapical tooth; inner style with a low dorsal tooth near middle. Aedeagus (Fig. 77) of a generalised type.

Female. As for male except as follows. Eyes separated by 3.5–3.8x width of anterior ocellus. Frontal tomentum greyish brown; pile a little shorter, all black. Occiput with about 35 macrosetae on either side. Thoracic macrosetae: 4 np and 2 (or 3) dc. Mesonotal tomentum greyish brown (as on frons). Darkening of posterodorsal surface of fore femora less pronounced. Abdomen appearing darker, with T2–5 showing gradually diminishing areas of dull grey-black colour; distinct anterior bands not formed. Pile short, pale, appressed on T2–4, black and more erect on subsequent tergites. Sternites grey with pale, erect pile.

Terminalia. S8 in face view (Fig. 232) squarish, with sparse pile, in profile (Fig. 233) with a low incurvation around middle. Third A1 seta about 7.5x as long as wide, blunt-tipped; 6 A1 setae per side. Longest A2 seta about twice as long as 3rd A1 seta; 6 A2 setae per side, plus some smaller setae.

Dimensions. Total length 9.5–10.0 mm, wing 8.5–9.0 mm.

Type data. Holotype: male, DN, Warrington Beach, sand dune area, 3 December 1977, E.I. Schlinger (CISB).

Paratypes: 2 females, same data as holotype (CISB, NZAC); 2 males, SL, New River, 7 and 21 December 1902, ? coll. (NZAC).

Material examined. Type series only.

— / DN, SL / —

Anabarhynchus femoralis Kröber

Figures 78–80, 234, 235

femoralis Kröber, 1932: 135 (*Anabarrhynchus*). Holotype female, New Zealand.

innotatus Walker var. *luridus* Schiner (*Anabarhynchus*). Kröber, 1932: 131.

caesius Kröber, 1932: 131, 142 (*Anabarrhynchus*); not Kröber, 1912.

Male. Head. Eyes separated in front of anterior ocellus by 3x its width. Frons distinctly raised from below anterior ocellus, white-grey to grey tomentose; pile black; longest setae as long as scape or longer. Face bare. Scape grey-black; flagellum black; terminal flagellar segments together about one-third as long as 1st segment. Occiput with about 50 black macrosetae on either side. Pile of lower occiput and genae white. Palpi yellow, slightly dilated at apex.

Thorax. Macrosetae: np 4–6 (–8), sa 2, pa 1, dc 2, sc 2; all setae black. Mesonotum with a pattern of white-grey and dark grey tomentum, the latter forming a medial band occupying one-fourth of mesonotal width, and with a dark brown pattern consisting of 3 narrow, continuous stripes, one in midline and a pair along outer margin of dark grey band; more laterally 2 additional, slightly wider brown stripes, interrupted at notopleural suture, and behind suture forming horseshoe-shaped spots; pile with mixed whitish and blackish setae. Scutellum brown-black on disc; pile long, whitish. Prosternal furrow, sternopleura, and posterior surface of middle coxae without pile. Pleura and coxae white-grey tomentose.

Legs. Fore femora with no macrosetae or 1 av; middle

femora without macrosetae; hind femora with 1 or 2 av and 1 or 2 pv. Femora yellow-brown, blackened to varying degrees on dorsal surface, especially towards apices. Hind femora with long, erect, whitish pile on ventral surface, some setae reaching or exceeding femoral width; white semi-scaly setae and short black setae present on dorsal surface. Tibiae yellow-brown.

Wings uniformly grey-hyaline; veins brownish, but Sc yellowish, and R_1 nearly blackish; stigma brown-black. Halteres pale yellowish.

Abdomen. Dorsum white-grey tomentose in strict dorsal view; in lateral view, lateral areas of tergites more or less distinctly yellow-brown or red-brown translucent, as for sternites. Abdominal pilosity whitish.

Terminalia brownish, with both epandrium and gonocoxites partly blackened; pile composed of black and yellowish setae. Epandrium (Fig. 78) tapering posteriorly, wider than long; cerci half as long as epandrium, broadly rounded apically. Gonocoxites (Fig. 79) characteristically extended posteromedially (easily observed without dissection), just touching ventrally; hypandrium large, reasonably discrete. Outer style sharply pointed; inner style with a low dorsal lobe. Aedeagus (Fig. 80) of a generalised type.

Female. As for male except as follows. Eyes separated by 4.5–4.7x width of anterior ocellus. Frontal tomentum often somewhat brownish-tinged; pile shorter. Mesonotum with greyish tomentum more or less intensely brownish-tinged (and some specimens with intense brown tomentum); pile shorter. In strict dorsal view T2–5 dull blackish, with posterior margin and a diffusely demarcated median stripe greyish, thus apparently with a double row of blackish spots; pile pale, but black on T5. T6 and T7 brown-black with black pile. In lateral view all tergites yellow-brown to red-brown along lateral margin, with some covering of white-grey tomentum.

Terminalia. S8 in face view as in Fig. 234, with a characteristic uniserial row of setae flanking a transverse, saddle-shaped depression on posterior half, in profile as in Fig. 235. Third A1 seta about 4x as long as wide, blunt-tipped to slightly spatulate; 6–8 A1 setae per side. Longest A2 seta about 3x as long as 3rd A1 seta; 6–9 A2 setae per side.

Dimensions. Body length 8–12 mm, wing 7.4–9.0 mm.

Type data. *A. femoralis* was described from a single female (BMNH) labelled: "Type", "Anabarhynchus / femoralis Krb. / det. Kröber 1931" and "New Zealand / J. Muggeridge". The holotype has lost both flagella, both wings, and parts of the legs, but is otherwise in good condition, i.e., not discoloured.

Material examined. Holotype, plus 53 non-type examples (29 males, 24 females; AMNZ, CISB, CMNZ, CNCI, IFPE, LCNZ, NZAC, OMNZ, ZMKD).

— / NN, MC, SC, OL, CO, DN / —

Anabarhynchus fenwicki new species

Figures 81–83, 236, 237

Male. Head. Eyes separated at narrowest point by slightly less than width of anterior ocellus. Frons not protruding, grey to white-grey tomentose; pile black; some setae as long as scape. Face bare. Scape greyish; flagellum blackish; terminal flagellar segments together about 0.4x as long as 1st segment. Occiput with about 50 black, rather weak macrosetae on either side; a few upper postoculars elongate; tomentum of upper occiput bluish grey. Lower occiput and genae with white pile. Palpi grey-brown, spatulate in distal half. Upper facets distinctly enlarged, rather sharply demarcated from smaller facets of lower part of eye.

Thorax. Macrosetae: np 3, sa 1 or 2, pa 1, dc 0, sc 2; all setae black, weak. Mesonotum and scutellum uniformly grey tomentose; pile on disc of mesonotum long, black; whitish setae intermixed laterally and posteriorly; scutellum with exclusively whitish pile. Prosternal furrow, sternopleura, and posterior surface of middle coxae without pile. Pleura and coxae white-grey tomentose.

Legs. Fore femora with 1 pd macroseta and 1 weak av; middle femora without macrosetae; hind femora with 2 av and 1 pv. Legs grey-black, with white pile; pile of hind femora uniform, semi-erect.

Wings uniformly grey-brown hyaline; veins and stigma brown-black. Halteres blackish.

Abdomen. T2 and T3 subshiny brown-black on anterior half, white-grey tomentose on posterior half and laterally. T4 brown-black, with posterolateral corners white-grey. T5 and T6 white-grey, with T5 narrowly brown-black along anterior margin. Pile of dorsum long, black on blackish areas, white on remainder. Sternites greyish with whitish pile.

Terminalia grey-black with blackish pile. Epandrium (Fig. 81) about twice as wide as long; cerci nearly as long as epandrium. Gonocoxites (Fig. 82) truncated posteriorly, fused for a long distance; hypandrial element small. Outer style relatively narrow and short; inner style with a large dorsal tooth on proximal half. Ventral lobe of gonocoxite remarkably large (best observed in caudal view). Aedeagus (Fig. 83) of a generalised type.

Female. As for male except as follows. Eyes separated by about 5x width of anterior ocellus, distinctly protruding over entire length; pile shorter, sparser. Occiput with about

30 weaker macrosetae on either side. Middle femora with 1 pv macroseta.

Terminalia. S8 in face view (Fig. 236) uniformly melanised, in profile (Fig. 237) slightly convex; pile restricted, simple, nearly absent from posterior lobe. Third A1 seta about 5X as long as wide, blunt-tipped; 6 A1 setae per side. Longest A2 seta about 1.5X as long as 3rd A1 seta; 5 or 6 A2 setae per side.

Dimensions. Body length about 7 mm, wing 6.5 mm.

Type data. Holotype: male, OL, Makarora, 1000–2000 ft [300–600 m], December 1924, Fenwick Coll. (NMNZ).

Paratype: 1 female, CO, Matukituki River, sand, 18 November 1989, A.C. Harris (OMNZ).

Material examined. Type specimens only.

— / CO, OL / —

Remarks. *A. fenwicki* is distinctive, and is probably the sister-species to *A. spitzeri*. Synapomorphic characters may be the marked blackish abdominal bands in the male, the remarkable difference in size of the outer and inner styles, and the low number of thoracic macrosetae.

Anabarhynchus flaviventris new species

Figures 84–86

Male. Head. Eyes separated in front of anterior ocellus by about twice its width. Frons slightly raised over a little more than lower half, grey-brown tomentose; pile black; setae as long as scape. Face bare. Scape brown-black; flagellum black; terminal flagellar segments together about half as long as 1st segment. Occiput with about 50 black macrosetae on either side. Pile on lower occiput and genae whitish. Palpi yellowish.

Thorax. Macrosetae: np 4, sa 1 or 2, pa 1, dc 2, sc 2; all setae black. Mesonotum and scutellum uniformly grey-brown tomentose, not patterned; pile rather long, composed of black and white-yellow hair-like setae; scutellar pile pale. Prosternal furrow, notopleura, and posterior surface of middle coxae without pile. Pleura and coxae greyish, the latter partly yellowish on external surface.

Legs. Fore and middle femora without macrosetae; hind femora with 1 or 2 av and 1 short pv. Femora yellow-brown, very slightly darkened at apices, owing partly to blackish pile. Pile of hind femora composed of whitish and blackish hair-like setae; whitish semi-scaly setae present on dorsal surface; length of pile on ventral surface one-third of femoral width. Tibiae yellow-brown, as for femora, not darkened towards apices.

Wings hyaline, with a more or less distinct yellowish tinge on basal part; veins pale yellow-brown, appearing nearly translucent; stigma darker brownish. Halteres yellow.

Abdomen. Tergites in dorsal view appearing greyish tomentose with narrow yellow-brown to yellow-red lateral areas; sternites yellow-brown to yellow-red. Pile mainly whitish.

Terminalia yellow-brown with pale pilosity. Epandrium (Fig. 84) slightly wider than long; cerci about half as long as epandrium. S10 with a pair of remarkably strong setae. Gonocoxites (Fig. 85) weakly fused for some distance; weak zones of fusion also between gonocoxites and hypandrium. Outer style with apex strongly curved, carrying minute setae. Aedeagus (Fig. 86) with phallic part thick-bodied, nearly parallel-sided, becoming very thin at apex.

Female. Unknown.

Dimensions. Body length about 10.5 mm, wing 8.4 mm.

Type data. Holotype: male, WN, Wellington, 1906, "154", G.V. Hudson (BMNH).

Material examined. Holotype only.

— / WN / —

Remarks. A male labelled "S.Is./Andrew's Str./Arthur's Pass N.P./XI-30-1977/E.I. Schlinger" (CISB) has genitalia practically identical with those of the holotype of *flaviventris*, except that S10 does not have a pair of setae. It is also very similar in external characters, except for a few pale setae posteriorly on the middle coxae. It may represent a distinct species, but a description should await further material.

Anabarhynchus fluviatilis new species

Figures 87–89, 238, 239

Male. Head. Eyes separated at narrowest point by less than half width of anterior ocellus. Frons not protruding, white-grey (below) to dark grey (above) tomentose; short black pile restricted to lower part; setae about half as long as scape. Face with a few pale setae. Scape white-grey; flagellum blackish; terminal flagellar segments together about half as long as 1st segment. Occiput with about 30–35 rather short black macrosetae on either side. Lower occiput and genae with white pile. Palpi grey-black.

Thorax. Macrosetae: np 4, sa 2, pa 1, dc 1, sc 2; all setae black. Mesonotum and scutellum bluish white-grey tomentose, unpatterned; pile composed of rather short black

and white setae. Prosternal furrow and sternopleura without pile; posterior surface of middle coxae with whitish pile. Pleura and coxae white-grey tomentose.

Legs. Fore femora with 2 or 3 pd macrosetae and 2 or 3 av; middle femora with 2 av and 3 pv; hind femora with 2 av and 2 pv. Femora and tibiae uniformly grey-black. Pile of hind femora exclusively whitish, on ventral surface semi-erect, half as long as femoral width, on dorsal surface longer, appressed to semi-scaly.

Wings greyish hyaline; veins blackish; stigma dark brown. Halteres blackish.

Abdomen uniformly white-grey tomentose, with short whitish pile.

Terminalia. Epandrium (Fig. 87) arched in both directions, strongly constricted towards posterior margin; pile short, sparse; cerci heavily sclerotised, arranged in a nearly dorsoventral position. Gonocoxites (Fig. 88) just touching ventrally, with a long, spatulate lateral extension and a shorter ventral extension bearing some strong setae. Outer style awl-shaped; inner style strong, complex, with dorso-basal and lateromedian lobes. Aedeagus (Fig. 89) with phallic part short, strongly S-curved.

Female. As male except as follows. Eyes separated by 6x width of anterior ocellus. Upper part of frons with a low furrow in midline; areas lateral of furrow slightly protruding in profile. Abdomen discoloured, but apparently T2 and T3 uniformly greyish tomentose and whitish pilose, and T4-7 subshiny grey with short, erect, black pile.

Terminalia. S8 in face view (Fig. 238) with a pair of slightly demelanised but not depressed areas on posterior half, in profile (Fig. 239) evenly convex; pile long, erect, not particularly strong, distributed to near anterior margin. Third A3 seta about 6x as long as wide, blunt-tipped; 7 A1 setae per side. Longest A2 seta about as long as 3rd A1 seta; 7 or 8 A2 setae per side.

Dimensions. Body length 10-12 mm, wing 7.8-9.8 mm.

Type data. Holotype: male, KA, Kowhai River, Kaikoura, 31 March 1974, D.I. Vanev (NZAC).

Paratypes: 1 female, same data as holotype (NZAC).

Material examined. Type specimens only.

— / KA / —

Anabarhynchus fuscifemoratus new species

Figures 90-92

Male. Head. Eyes separated in front of anterior ocellus by 2.5x its width. Frons markedly protruding in lower half,

grey-brown (above) to grey (below) tomentose; pile very long, with some setae 1.5x as long as scape. Face bare. Scape greyish; flagellum blackish; terminal flagellar segments together less than half as long as 1st segment. Occiput with about 70 black macrosetae on either side. Pile of lower occiput and genae whitish. Palpi yellowish.

Thorax. Macrosetae: np 4, sa 2, pa 1, dc 2, sc 2; all setae black, extraordinarily long and strong. Mesonotum (partly discoloured) with a pattern of grey-brown and dark brown tomentum on disc, laterally pure greyish; pile long, composed of black and whitish setae. Disc of scutellum dark brown; pile whitish. Prosternal furrow, sternopleura, and posterior surface of middle coxae without pile. Pleura and coxae greyish tomentose.

Legs. Fore and middle femora each with 1 av macroseta; hind femora with 1 av and 1 pv. Femora brownish grey; tibiae yellowish brown. Pile of hind femora whitish; setae on ventral surface about half as long as femoral width.

Wings greyish hyaline, with veins and stigma brownish. (Halteres missing.)

Abdomen white-grey tomentose; lateral parts of tergites and entire sternites slightly brownish translucent; pile whitish, long.

Terminalia yellowish with whitish pile. Epandrium (Fig. 90) about as wide as long; cerci small, less than half as long as epandrium. Gonocoxites (Fig. 91) forming a ventral synsclerite, i.e., with no distinct zone of fusion; hypandrial element with distinct zones of fusion. Outer and inner styles short, simple. Aedeagus (Fig. 92) of a generalised type.

Female. Unknown.

Dimensions. Body length about 9 mm, wing 6.8 mm.

Type data. Holotype: male, DN, Dunedin, Portobello, 19 September 1975, A.C. Harris (OMNZ).

Material examined. Holotype only.

— / DN / —

Anabarhynchus gibbsi new species

Figures 93-95, 240, 241

Male. Head. Eyes separated in front of anterior ocellus by 4.4x its width. Frons slightly protruding in lower part, grey-brown tomentose; pile black; setae about as long as scape. Face bare. Scape grey-black; flagellum blackish; terminal flagellar segments together about half as long as 1st segment. Occiput with about 60 strong black macrosetae on either side. Pile of lower occiput and genae white-yellow. Palpi greyish at apex and base, brownish at middle.

Thorax. Macrosetae: np 5 or 6, sa 2, pa 1, dc 2, sc 2; all setae black, very strong. Mesonotum on disc dark brown tomentose, with 2 paler grey and 3 darker brown stripes, laterally pale greyish tomentose; pile moderately long, black. Scutellum brown-black, with posterior margin pale greyish; pile black on disc, whitish along margin. Prosternal furrow, sternopleura, and posterior surface of middle coxae without pile. Pleura and coxae greyish.

Legs. Fore femora with 3 av macrosetae; middle femora with 3 pv; hind femora with 2 av and 1 pv. Femora blackish, only slightly tomentose. Pile on ventral surface of hind femora white-yellow, semi-erect, with longest setae about as long as half femoral width; dorsal surface with erect black setae and appressed, white-yellow, semi-scaly setae. Tibiae brownish with apical parts blackened.

Wings grey-brown hyaline; stigma and veins brown-black. Halteres yellowish, in part blackened.

Abdomen. Disc of tergites dull blackish with appressed black pile, lateral parts greyish tomentose with longer, more erect whitish pile; demarcation line almost parallel to abdominal margin. Sternites greyish with whitish pile.

Terminalia brown-black with black pile. Epandrium (Fig. 93) about as wide as long, with dense pile; cerci about two-thirds as long as epandrium, sharply pointed. Gonocoxites (Fig. 94) with distinct zones of fusion with each other and with hypandrial element. Outer style with apical part club-shaped, and with a sharp tooth some distance from apex. Aedeagus (Fig. 95) of a generalised type.

Female. As for male except as follows. Eyes separated by about 5x width of anterior ocellus. Femora with fewer macrosetae: 2 av on fore femora, 1 pv on middle femora, and 1 av on hind femora.

Terminalia. S8 in face view (Fig. 240) with a large, slightly depressed, V-shaped demelanised area, in profile (Fig. 241) with a very slight incurvation at middle; pile very rich, composed of relatively weak setae. Third A1 seta about 8x as long as wide, narrowly blunt-tipped; 7 A1 setae per side. Longest A2 seta about 1.4x as long as 3rd A1 seta; 6 or 7 A2 setae per side.

Dimensions. Body length 13–15 mm, wing 10.4–11.5 mm.

Type data. Holotype: male, NN, Farewell Spit, 8 March 1981, G.W. Gibbs (NZAC).

Paratypes: 1 female, same data as holotype (NZAC); 1 female, ND, Omamari Beach N of Dargaville, 5 March 1969, J.E. Tobler (CASC).

Material examined. Type specimens only.

— / ND / NN / —

Remarks. *A. gibbsi* is probably related to *A. embersoni* (q.v.). The collection dates suggest occurrence of adults rather late in the summer.

Anabarhynchus grossus new species

Figures 96–98, 242, 243

Male. Head. Eyes separated in front of anterior ocellus by 4x its width. Frons markedly protruding over entire length, greyish tomentose, in part with a brownish tinge; pile black; setae about as long as scape. Face bare. Scape grey-black; (Flagella missing in holotype). Occiput with about 50 strong black macrosetae on either side. Pile of lower occiput and genae white-yellow. Palpi greyish-brown.

Thorax. Macrosetae: np 4–6, sa 2 or 3, pa 1, dc 0, sc 2; all setae strong, black. Mesonotum dark greyish tomentose, with traces of 5 dark brown stripes; pile long, exclusively black. Scutellum grey with black pile. Prosternal furrow, sternopleura, and posterior surface of middle coxae without pile. Pleura and coxae greyish tomentose.

Legs. Fore femora with 1 or 2 av macrosetae; middle femora without macrosetae, or with 1 weak pv; hind femora with 1 or 2 av and 2 or 3 pv. Femora blackish, only slightly tomentose. Pile on ventral surface of hind femora semi-erect, pale, the setae about one-third as long as femoral width; pile on dorsal and anterior surfaces blackish, appressed. Tibiae blackish.

Wings grey-brown hyaline, most intensely coloured in brown-black streaks along veins and on stigma. Halteres brown-black.

Abdomen. Tergites greyish black and subshiny on disc; pile blackish, appressed; posterolateral corners greyish tomentose with white-yellow pile. Sternites greyish with white-yellow pile.

Terminalia brownish black; pile black. Epandrium (Fig. 96) about 1.5x as wide as long, with posterolateral corners projecting; cerci about half as long as epandrium. Gonocoxites (Fig. 97) with a posteromedially directed extension, fused for some distance, with hypandrial element incorporated. Outer style slender, curved, sharply pointed at apex, with remarkably long, fine setae in apical part. Aedeagus (Fig. 98) of a generalised type; basiphallitic sclerite minute.

Female. As for male except as follows. Eyes separated by 5x width of anterior ocellus. Frons with a distinct brownish tinge of tomentum on middle third. Occiput with about 35 macrosetae on either side. Wings with more distinct brown streaks along veins. Abdomen with pile nearly all blackish.

Terminalia. S8 in face view (Fig. 242) showing 2 deep depressions separated by a sharp keel, in profile (Fig. 243)

with a deep incurvation of posterior half; a group of about 12 rather strong, medially directed setae at posterolateral corner of each depression, and some anteriorly directed setae on posterior part of median keel. Third A1 seta about 4.5X as long as wide, broadly blunt-tipped; 8 A1 setae per side. Longest A2 seta about 2.5X as long as 3rd A1 seta; 8 A2 setae per side.

Dimensions. Body length about 14 mm, wing about 11.5 mm.

Type data. Holotype: male, WD, Waiho Gorge, S.W. [South Westland], 22 January 1924, E. Richardson (NMNZ).

Paratypes: 1 female, OL, Wallace Cn., end 5th arm Lake Te Anau, 3 January 1925, Kepler (AMNZ).

Material examined. Type specimens only.

— / WD, OL / —

Anabarhynchus harrisi new species

Figures 99–101, 244, 245

Male. Head. Eyes separated at narrowest point by about half width of anterior ocellus. Frontal pile restricted to lower area; setae black, shorter than scape. Face laterally with a few short black setae. Antennae discoloured; terminal flagellar segments together about half as long as 1st segment. Occiput with about 10 short black macrosetae on either side. Lower occiput and genae with whitish pile. Upper facets strongly enlarged. Ocelli slightly elevated.

Thorax. Macrosetae: np 4, sa 2, pa 1, dc 0, sc 2; all setae black, weak. Mesonotum discoloured (but see female, below); pile composed of black and white setae. Prosternal furrow and sternopleura without pile; posterior surface of middle coxae with some pile.

Legs. See description of female; legs of holotype discoloured, and setae rubbed off.

Wings with a characteristic whitish yellow tinge; veins and stigma blackish. Halteres blackish.

Abdomen entirely discoloured in holotype.

Terminalia. Epandrium (Fig. 99) 1.2X as wide as long; cerci small. Gonocoxites (Fig. 100) truncated posteriorly, fused for a long distance, with no trace of a hypandrial element. Outer style short, slender, blunt-tipped; inner style with a very large, rounded lobe proximally. Aedeagus (Fig. 101) of a generalised type.

Female. As for male except as follows. Eyes separated by about 10X width of anterior ocellus (ocelli unusually small). Frontal tomentum greyish; pile short, black, restricted.

Antennae blackish. Mesonotum appearing uniformly pale greyish tomentose. Fore femora with 1 or 2 pd macrosetae and 1 or 2 av; middle femora with 0 or 1 av and 1–3 pv; hind femora with 1 or 2 av. Femora and tibiae grey-black. Dorsum of abdomen appearing uniformly greyish tomentose (in male perhaps silvery grey-white).

Terminalia. S8 in face view (Fig. 244) without impressed or demelanised areas, in profile (Fig. 245) nearly straight; pile unmodified, evenly distributed. Third A1 seta 8–9X as long as wide, blunt-tipped; 8 A1 setae per side. Longest A2 seta as long as 3rd A1 seta; 5 or 6 A2 setae per side.

Dimensions. Body length 8–10 mm, wing 7.5–8.2 mm.

Type data. Holotype: male, MK, Blue Stream, ex larva 25 January 1989, A.C. Harris (OMNZ).

Paratypes: 2 females, same data as holotype (OMNZ).

Material examined. Type specimens only.

— / MK / —

Remarks. *A. harrisi* is coloured like the small grey and white pebbles on which it occurs. The fly is about when the sphecid *Podagritys cora* and *P. albipes* are stocking their nests in sandy soil with mayflies and caddisflies. The larva of *A. harrisi* moves through the sandy soil and devours the contents of the sphecid cells. It eats also paralysed spiders (mainly Lycosidae) with which *Priocnemis (Trichocurgus) nitidiventris* provisions its underground cells (A.C. Harris, pers. comm.).

Anabarhynchus hayakawai new species

Figures 102–104, 248, 249

Male. Head. Eyes separated in front of anterior ocellus by twice its width. Frons slightly protruding in lower part, grey-brown to cinnamon-brown tomentose; pile black; longest setae about as long as scape. Face bare. Scape grey-black; flagellum blackish; terminal flagellar segments together longer than half length of 1st segment. Occiput with about 50–60 black macrosetae on either side. Pile of lower occiput and genae whitish. Palpi grey-black.

Thorax. Macrosetae: np 4 or 5, sa 2, pa 1, dc 2, sc 2; all setae black, strong. Mesonotum partly discoloured in holotype, but apparently uniformly brown-grey tomentose; pile short, black; longer, yellowish, hair-like setae intermixed laterally and posteriorly. Scutellum brown-black on disc, greyish along posterior margin; pile yellowish. Prosternal furrow, sternopleura, and posterior

surface of middle coxae without pile. Pleura and coxae greyish tomentose.

Legs. Fore femora with 1 or 2 pd macrosetae and 1 or 2 av; middle femora with 1 pv; hind femora with 1 av and 1 or 2 pv. Femora grey-black. Pile on ventral surface of hind femora short, whitish, the setae at most one-third as long as femoral width; pile on dorsal surface composed of appressed, semi-scaly, whitish setae and erect black setae. Tibiae yellow-brown.

Wings grey-black hyaline, with veins brown-black and stigma pale brownish. Halteres blackish.

Abdomen. Tergites with very marked, subshiny blackish anterior bands nearly reaching posterior margin in midline; posterolateral areas white-grey tomentose. Pile black and appressed on dark areas, white and semi-erect on white-grey areas. Sternites greyish with whitish pile.

Terminalia. Epandrium (Fig. 102) about as wide as long; cerci two-thirds as long as epandrium, pointed. Gonocoxites (Fig. 103) touching for a short distance, showing very marked zones of fusion with hypandrial element, this being rather irregular and bearing a few short setae; a V-shaped hyaline area is formed. Outer style with apex blunt and with a blunt-tipped subapical tooth. Aedeagus (Fig. 104) of a generalised type.

Female. As for male except as follows. Eyes separated by 3x width of anterior ocellus. Hind femora with up to 4 av macrosetae. T5 and succeeding tergites with strong black pile.

Terminalia. S8 in face view (Fig. 248) with a complete transverse depression, in profile (Fig. 249) with a marked incurvation of posterior half; pile weak, with all setae anteriorly directed. Third A1 seta 4–5x as long as wide, blunt-tipped; 8 or 9 A1 setae per side. Longest A2 seta about 1.8x as long as 3rd A1 seta; 7 A2 setae per side.

Dimensions. Body length 10–12 mm, wing 9.2–10.3 mm.

Type data. Holotype: male, TO, Tongariro National Park, Waihothonu Track, 9 January 1965, J.S. Armstrong (NZAC).

Paratypes: 1 female, CL, Coromandel, 4 March 1973, H. Hayakawa (ZMKD); 1 male, BP, Mamaku, 28 December 1920, Clarke Coll. (ZMKD); 1 male, 1 female, TO, Taupo, Palmers Bush, 31 December 1933, J.S. Armstrong (NZAC); 1 female, same data as holotype; 1 male, GB, Urewera National Park, Lake Waikaremoana, 9–10 December 1972, I.M. Mackerras & G.B. Fairchild (ZMKD).

Material examined. Type series only.

— / CL, BP, TO, GB / —

Anabarhynchus hudsoni new species

Figures 105–107

Male. Head. Eyes separated in front of anterior ocellus by about 3x its width. Frons white-grey tomentose, markedly protruding on lower part; pile black; setae about as long as scape. Face bare. Scape grey-black; flagellum black; terminal flagellar segments together about two-fifths as long as 1st segment. Occiput with about 4.5 black macrosetae on either side. Pile of lower occiput and genae whitish. Palpi yellow-brown.

Thorax. Macrosetae: np 4–6, sa 2, pa 1, dc 2, sc 2; all setae black. Mesonotum greyish tomentose, with 3 weak traces of brown longitudinal stripes; pile short, black; paler pile present laterally and posteriorly. Scutellum grey with disc brownish; pile whitish. Prosternal furrow without pile; sternopleura with some whitish pile on upper part; posterior surface of middle coxae with a few whitish setae. Pleura and coxae uniformly white-grey tomentose.

Legs. Fore femora without macrosetae on right side, with a weak av on left side; middle femora without macrosetae; hind femora with 1 av and 1 pv. Femora yellow-brown, with slight white tomentum. Tibiae yellow-brown. Pile of hind femora whitish, short.

Wings uniformly grey-brown hyaline; veins and stigma brown-black. Halteres blackish.

Abdomen. Tergites greyish, but T2–5 with ill marked, darker, paired spots due to combination of dark tomentum and black pile. Sternites white-grey with whitish pile.

Terminalia brown-black, with a mixture of blackish and pale setae. Epandrium (Fig. 105) about as wide as long; cerci small, roundish; ventral epandrial sclerite (= S10+11) with deep lateral rims. Gonocoxites (Fig. 106) broadly rounded posteriorly, fused for some distance behind the narrow, triangular hypandrial element. Outer style remarkably short and stumpy, with a sharp interior corner. Aedeagus (Fig. 107) with phallic part suddenly downcurved, gradually narrowing apicad.

Female. Unknown.

Dimensions. Body length about 7.5 mm, wing 5.9 mm.

Type data. Holotype male: WN, karaka [*Corynocarpus laevigatus*] grove beyond Ohiro Bay, 2 November 1921, G.V. Hudson (Hudson Coll. no. 419a, NMNZ).

Material examined. Holotype only.

— ; WN / —

Remarks. *A. hudsoni* and *A. laterepilosus* are the only New Zealand *Anabarhynchus* with long whitish pile on the

sternopleura. Whether this is a plesiomorphic character state or represents a synapomorphy for these two species seems unclear.

Anabarhynchus huttoni new species

Figures 108–110, 246, 247

luridus Schiner (*Anabarhynchus*). Hutton, 1901: 25 (part).

Male. Head. Eyes separated in front of anterior ocellus by 2.1–2.4x its width. Frons golden brown-grey tomentose, slightly protruding on lower part; pile sometimes black, but usually with some setae pale brownish or all pale; setae shorter than scape. Face bare. Scape grey-black; flagellum blackish; terminal flagellar segments together slightly more than half as long as 1st segment. Occiput with 50–60 strong black macrosetae on either side. Pile of lower occiput and genae whitish. Palpi yellow-brown.

Thorax. Macrosetae: np 4 or 5, sa 2, pa 1, dc 2, sc 2; all setae black, strong. Mesonotum yellowish grey-brown tomentose, with 3 darker bands and traces of darker brown stripes; pile short, composed of erect blackish setae and more appressed pale brownish setae. Scutellum grey-brown on disc, grey along margin; pile pale brownish. Prosternal furrow, sternopleura, and posterior surface of middle coxae without pile. Pleura and coxae with a greyish tomentum.

Legs. Fore femora with 1 or 2 av macrosetae; middle femora usually with 1 or 2 av; hind femora with 1 or 2 av and 1 or 2 pv. Femora blackish, moderately tomentose. Pile of hind femora white-yellow; hair-like setae on ventral surface semi-erect, in length about half femoral width; setae on dorsal surface appressed, semi-scaly. Tibiae yellow-brown.

Wings grey-brown hyaline, with stigma pale brownish and veins brown to brown-black. Halteres yellowish brown.

Abdomen. Tergites mostly greyish to yellowish-grey tomentose, with more or less distinct, semicircular, grey-black or blackish anterior areas, most distinct on T2–4. Posterolateral areas of T2 and T3 usually slightly brownish translucent. Tergal pile mostly whitish to yellowish; black appressed setae present on blackish areas. Sternites more or less yellow-brown translucent; pile white-yellow.

Terminalia brownish with yellowish pile. Epandrium (Fig. 108) slightly wider than long; cerci moderately elongate and pointed. Gonocoxites (Fig. 109) with marked zones of fusion with each other and with hypandrial element. Outer style moderately stout, with apex simple, sharp. Aedeagus (Fig. 110) of a generalised type.

Female. As for male except as follows. Eyes separated by 2.9–3.3x width of anterior ocellus. Pile on ventral surface of hind femora shorter. Dark bands on T2–4 blackish

pilose, nearly reaching posterior margin in midline; lateral and posterolateral areas of T2–4 grey tomentose, with hair-like, yellowish, appressed pile. T5–7 subshiny grey-black medially and anteriorly, more grey tomentose laterally and posteriorly; pile stiff, semi-erect, black.

Terminalia. S8 in face view (Fig. 246) with an oval, slightly depressed and demelanised area, in profile (Fig. 247) with a moderate incurvation at middle; pile restricted, rather weak. Third A1 seta about 6x as long as wide, blunt-tipped; 7 or 8 A1 setae per side. Longest A2 seta about 1.6x as long as 3rd A1 seta; 7 or 8 A2 setae per side.

Dimensions. Body length 9–10 mm, wing 8.0–9.1 mm.

Type data. Holotype: male, without data, labelled “*Anabarhynchus luridus* Schin. / F.W. Hutton det.” (CMNZ).

Paratypes: 1 male, BP, Tauranga, 10 January 1950, G.W. Ramsay (NMNZ); 1 female, TO, Taupo, 6 January 1964, J.S. Armstrong (NZAC); 1 female, TO, Taupo, 30 January 1984, W.W. Middlekauff (CASC); 1 male, TO, Taupo, 24 December 1932, J.S. Armstrong (NZAC); 1 female, NN, Rabbit I., February 1973, A.K. Walker (NZAC); 2 males, MC, Christchurch, Sth Brighton dunes, 8 December 1974, R.P. Macfarlane (NZAC); 1 male, MC, Christchurch, Bromley, 11 January 1964, W.P. Thomas (NZAC); 1 male, MC, Christchurch, Woolston, 16 February 1964, W.P. Thomas (NZAC); 1 male, DN, Taieri Is, Otago, 30 January 1955, B.A. Holloway (NZAC).

Material examined. Type series only.

— / BP, TO / NN, MC, DN / —

Anabarhynchus indistinctus new species

Figures 114–116

Male. Head. Eyes separated in front of anterior ocellus by 2.4x its width. Frons dark grey tomentose, not protruding in lateral view; pile black, with setae strong, about as long as scape. Face with a few pale setae. Scape greyish; flagellum blackish; terminal flagellar segments together slightly shorter than half length of 1st segment. Postocular area with about 45 black macrosetae on either side. Pile of lower occiput and genae whitish. Palpi grey-brown.

Thorax. Macrosetae: np 3, sa 1 or 2, pa 1, dc 1, sc 2; all setae black, relatively weak. Mesonotum and scutellum uniformly dark greyish tomentose; mesonotal pile long, black; whitish setae intermixed laterally and posteriorly; scutellar pile long, whitish. Prosternal furrow and sternopleura without pile; posterior surface of middle coxae with whitish pile. Pleura and coxae greyish tomentose.

Legs. Fore femora with 1 pd macroseta and 2 av; middle

femora with 1 av; hind femora with 1–3 av and 1 pv. Legs blackish; femora with a slight greyish tomentum. Pile on hind femora whitish, semi-erect on ventral surface, appressed on dorsal surface.

Wings uniformly grey-brown hyaline; veins and stigma brown-black. Halteres black.

Abdomen uniformly greyish tomentose; pile whitish, long.

Terminalia greyish-black, with black pile. Epandrium (Fig. 114) slightly wider than long; cerci about half as long as epandrium, moderately pointed. Gonocoxites (Fig. 115) with a sharp posterior projection, fused for a short distance in midline, and with zones of fusion with hypandrial element. Outer style very slender-bodied; inner style at base with a large, rounded dorsal lobe. Aedeagus (Fig. 116) of a generalised type.

Female. Unknown.

Dimensions. Body length about 7 mm, wing 6.4 mm.

Type data. Holotype: male, NC-WD, Arthurs Pass National Park, Andrews Stream, 30 November 1977, E.I. Schlinger (CISB).

Material examined. Holotype only.

— / NC-WD / —

***Anabarhynchus innotatus* (Walker)**

Figures 117–119, 252, 253

innotata Walker, 1856: 455 (*Thereva*). Holotype female, New Zealand.

luridus Schiner, 1868: 148 (*Anabarhynchus*) new synonymy. Holotype female, New Zealand.

modestus Kröber, 1932: 132 (*Anabarhynchus*) new synonymy. Holotype female, New Zealand.

Male. Head. Eyes separated in front of anterior ocellus by about 3.5x its width. Frons grey-yellow to grey-brown tomentose, slightly protruding in lower part; pile black, erect (some lower setae occasionally demelanised); setae shorter than scape. Face with 2–7 black or pale setae. Scape grey to grey-brown; flagellum black; terminal flagellar segments together longer than half length of 1st segment. Occiput with 35–40 strong black setae on either side. Pile of lower occiput and genae white-yellow. Palpi grey-brown to greyish.

Thorax. Macrosetae: np 4–6, sa 2, pa 1, dc 2 or 3, sc 2; all setae black, strong. Mesonotum brown-grey, with an indistinct pattern of 5 darker brown stripes; pile black on disc; yellow-brown setae present laterally and posteriorly.

Scutellum dark brown on disc, grey to grey-brown along margin; pile composed of both pale and blackish setae. Prosternal furrow with dense whitish pile; sternopleura without pile; posterior surface of hind coxae usually with a slight pile. Pleura and coxae greyish tomentose, with a tinge of brownish on upper parts.

Legs. Fore femora with 1 or 2 av macrosetae; middle femora with a few (usually 2 or 3) pv, sometimes very weak; hind femora with 1 or 2 av and 1 or 2 pv at apex. Femora blackish (but knees yellowish), intensely greyish tomentose. Pile of hind femora short, pale, appressed to semi-erect; additional short, black, erect setae present on dorsal surface. Tibiae yellowish brown, gradually darker apicad.

Wings with a rather intense brown-grey tinge, especially in streaks along veins; veins and stigma brownish. Halteres with knob brown-black.

Abdomen. T2–4 nearly entirely shiny black in strict dorsal view, with only narrow posterolateral areas appearing greyish, laterally entirely greyish; remaining tergites blackish dorsally and tomentose posteriorly and laterally. Pile black on darker areas, pale on tomentose areas. Sternites greyish with pale pilosity.

Terminalia blackish, with posterior epandrial margin and cerci usually more or less brownish. Epandrium (Fig. 117) slightly wider than long; cerci about one-third as long as epandrium. Gonocoxites (Fig. 118) simply and broadly rounded posteriorly, fused for some distance, and fused with rather discrete hypandrium. Outer style moderately thick-bodied, shorter than inner style, with a sharp apex. Aedeagus (Fig. 119) of a generalised type.

Female. As for male except as follows. Eyes separated by 4.2–4.5x width of anterior ocellus. Occiput with less than 30 macrosetae on either side.

Terminalia. S8 in face view (Fig. 252) with a very deep, oval to circular depression on posterior half covering about half of sternal width, in profile (Fig. 253) with a marked incision around middle; pile composed of irregularly, biserially arranged strong setae laterad of depression and a restricted short pile on posterior lobe. Third A1 seta about 5x as long as wide, blunt-tipped; 7–9 A1 setae per side. Longest A2 seta about twice as long as 3rd A1 seta; 6 or 7 A2 setae per side.

Dimensions. Body length 9–12 mm, wing 8.6–11.4 mm.

Type data. Walker described *Thereva innotata* from a single female. The holotype (BMNH) is in reasonably good condition; it originates from the W.W. Saunders Collection. There is no information on provenance, but it probably came from the Auckland area.

Schiner described *Anabarhynchus luridus* from one female specimen (not a male as stated in the description). The head and right middle femur of the holotype (NHMW) are missing, but it is otherwise in good condition, and is clearly conspecific with *A. innotatus*. According to the description it originates from the Auckland area.

Kröber described *A. modestus* from one female specimen labelled "Rangitoto 21.XII." The frons and mesonotum of the holotype (BMNH) are greasy, but the specimen is otherwise in good condition and easily recognisable as being conspecific with *A. innotatus*.

Material examined. Type series, plus 155 non-type examples (80 males, 75 females; AMNZ, BMNH, CASC, CISB, CMNZ, CNCI, LCNZ, NMNZ, NZAC, OMNZ, USNM, ZMKD).

—/ND, AK, WO, TO, HB, RI, WI, WN, WA/NN, BR, KA, NC, MC, MK, CO, OL /—

Remarks. The taxon proposed here has the following combination of characters: (a) prosternum with pile in median furrow, (b) lateral part of face with some pile (2–7 short, pale or black setae on either side); (c) middle femora with from one to several pv macrosetae; and (d) female S8 with a deep, oval to circular depression on posterior half (Fig. 252). Character 'a' is easily observable, and probably represents a plesiomorphy, as does character 'b' (note that these small facial setae are easily rubbed off). Characters 'c' and 'd' both represent apomorphic conditions.

This is by far the commonest and most widely distributed therevid in New Zealand. It seems to be represented by a number of allopatric 'microspecies', for which the names *innotatus* Walker, *luridus* Schiner, and *modestus* Kröber are available. Type examinations have shown that these are synonyms, and all apply to the population occurring in the Auckland area. The above description is based solely on material from the Auckland and Taupo areas.

There is considerable variation in certain characters between the various populations. The topotypic series has yellowish-brown tibiae and intense brownish frontal and mesonotal tomentum. In other populations the tibiae are extensively darkened, and the tomentum may be pure grey. The depression in the female S8 varies in width, from one-third to nearly two-thirds of the sternal width.

Anabarhynchus lacustris new species

Not figured

Male. Head. Eyes separated in front of anterior ocellus by 2.6–2.8x its width. Frons dark grey-brown tomentose, the tomentum forming 2 small, brown lateral spots on middle,

slightly protruding in lower part; pile stiff, black; most setae as long as scape. Face bare. Scape grey-black; flagellum blackish; terminal flagellar segments together about one-third as long as 1st segment. Occiput with 45–50 strong black macrosetae on either side. Lower occiput and genae with whitish pile. Palpi greyish.

Thorax. Macrosetae: np 4–6, sa 2, pa 1, dc 2, sc 2 or 3; all setae black, strong. Mesonotum uniformly greyish tomentose, unpatterned, but tomentum often with a slight brownish tinge; pile moderately long, composed of both pale and blackish setae. Scutellum greyish with white pile. Prosternal furrow, sternopleura, and posterior surface of middle coxae without pile. Pleura and coxae uniformly greyish tomentose.

Legs. Fore femora with 1 or 2 pd macrosetae and 1 or 2 av; middle femora without macrosetae or with 1 or 2 pv; hind femora with 1 av and 1 pv. Femora and tibiae grey-black. Pile of hind femora moderately long, appressed to semi-erect.

Wings whitish hyaline, with 12 more or less distinct areas of dark microtrichia; veins and stigma brown-black; a few minute setae present dorsodistally on R₁, in section crossing stigma. Halteres with knob whitish yellow, blackened around base.

Abdomen stumpy. Tergites dark greyish, appearing slightly darkened on anterior part of T2 and T3; pile short, appressed to semi-erect, composed mainly of pale setae, but black setae present on dark areas of T2 and T3. Sternites greyish with pale pilosity.

Terminalia practically identical with those of *A. nebulosus* (see Fig. 156–158), but epandrium apparently more constricted towards posterior margin, cerci smaller, and hypandrial element less evident than shown in Fig. 156.

Female. As for male but eyes separated by about 4.5x width of anterior ocellus.

Terminalia. S8 and setae of ovipositor as for *nebulosus* (see Fig. 274, 275).

Dimensions. Body length 7–9 mm, wing 6.1–6.8 mm.

Type data. Holotype: male, GB, E side Lake Waikaremoana, beach in picnic area, 700 m, 6 November 1977, E.I. Schlinger (CISB).

Paratypes: 23 males, 4 females (including 3 pairs taken in copulo), same data as holotype (CISB, NZAC, ZMKD).

Material examined. Type series only.

—/GB /—

Remarks. *A. lacustris* belongs in the clearly monophyletic *nebulosus*-group, which is discussed under *A. nebulosus*.

Anabarhynchus laterepilosus new species

Figures 120–122, 256, 257

Male. Head. Eyes separated in front of anterior ocellus by 3.1–3.3x its width. Frons uniformly pale grey-brown tomentose, markedly protruding over entire length; pile soft, pale; setae longer than scape. Face bare. Scape greyish; flagellum blackish; terminal flagellar segments together about one-third as long as 1st flagellar segment. Postocular macrosetae numerous, weak, demelanised. Pile of lower occiput and genae whitish. Palpi yellowish.

Thorax. Macrosetae: np 3–5 (the anteriormost often demelanised), sa 2, pa 1, dc 1 or 2, sc 2. Mesonotum with 3 broad, grey-brown to dark brown bands separated by 2 white-grey stripes; pile long, pale. Scutellum grey-brown to grey; pile whitish. Prosternal furrow without pile; sternopleuron and posterior surface of middle coxae with yellowish pilosity. Pleura and coxae greyish tomentose.

Legs. Fore femora with 2–4 av macrosetae and 1 or 2 pv; middle femora with 2 or 3 pv; hind femora with 1 or 2 av and 1 or 2 pv. Femora brownish, with thin grey-white tomentum. Pile of hind femora rather short, semi-appressed, pale. Tibiae brownish.

Wings white-grey hyaline, with slight brownish streaks along veins; veins brown-black, very strong; stigma pale brownish. Halteres yellowish.

Abdomen greyish tomentose, with anterior parts of all tergites dull grey-brown; pile whitish.

Terminalia grey-brown with whitish pile. Epandrium (Fig. 120) about twice as wide as long; pile very weak, evenly distributed; cerci about two-thirds as long as epandrium. Gonocoxites (Fig. 121) not fused but connected via a hyaline area, each with a rectangular posterior extension; hypandrium remarkably discrete. Outer style sharply pointed; inner style with a dorsomedian lobe. Aedeagus (Fig. 122) with phallic part remarkably long and slender.

Female. As for male but eyes separated by about 3.6x width of anterior ocellus.

Terminalia (Fig. 256, 257). S8 in face view (Fig. 256) with 2 small desclerotised areas at posterior margin, in profile (Fig. 257) with a slight incurvation of posterior half; pile very weak, uniform, with all setae directed posterad. Third A1 seta 12–14x as long as wide, sharp-pointed; 8 A1 setae per side. Longest A2 seta about as long as 3rd A1 seta; 6 or 7 A2 setae per side.

Dimensions. Body length 8–10 mm, wing 7.6–8.1 mm.

Type data. Holotype: male, WN, 2 km S of Paekakariki, 13 November 1977, E.I. Schlinger (CISB).

Paratypes: 1 male, ND, Ahipara Beach, on sand, 13 January 1988, K.A.J. Wise (AMNZ); 1 male, 2 females, ND, Waimamaku Beach, coastal scrub and dunes, 15 October 1967, J.S. Dugdale (NZAC); 1 male, AK, S end of Muriwai Beach, on sand, 25 January 1988, K.A.J. Wise (AMNZ); 1 male, CL, Ohui, N of Waihi, sand dune area, 2 November 1977, E.I. Schlinger (CISB); 9 males, 9 females (3 pairs in copulo), same data as holotype (CISB, NZAC, ZMKD).

Material examined. Type series only.

— / ND, AK, CL, WN / —

Remarks. *A. laterepilosus* is the only New Zealand species with a uniform pale pilosity over the entire surface of the sternopleuron; I regard this as a plesiomorphic character. The separate gonocoxites and discrete hypandrium of the male and the uniform pile of the female S8 may also be plesiomorphic characters. See also *A. hudsoni*.

Anabarhynchus latus new species

Figures 123–126, 254, 255

Male. Head. Eyes separated in front of anterior ocellus by about 4x its width. Frons greyish to grey-brown tomentose, moderately protruding for most of its length; pile black; some lower setae as long as scape. Face bare. Scape greyish; flagellum blackish; terminal flagellar segments together only about one-third as long as 1st segment. Occiput with 45–55 black macrosetae on either side. Pile of lower occiput and genae whitish. Palpi greyish brown.

Thorax. Macrosetae: np 3–5, sa 2, pa 1, dc 1–3, sc 2; all setae black, strong. Mesonotum greyish tomentose, practically unpatterned, or at most with very weak traces of brown stripes; pile moderately long, usually exclusively black, but if pale setae intermixed then these restricted to lateral and posterior parts. Scutellum uniformly greyish, with exclusively black setae or a mixture of blackish and yellowish setae. Prosternal furrow, sternopleura, and posterior surface of middle femora without pile. Pleura and coxae greyish.

Legs. Fore femora with 1 av macroseta; middle femora usually with 1 weak pv; hind femora with 1 or 2 av and 1 or 2 pv. Femora blackish, only slightly tomentose. Pile of hind femora short, composed mainly of white-yellow setae, with only a few black setae intermixed; pile on ventral surface shorter than one-quarter of femoral width. Tibiae dark brownish to brown-black.

Wings grey-brown hyaline, with veins and stigma brown-black. Halteres blackish.

Abdomen. Tergites grey-black on disc, pure greyish laterally and posterolaterally. Short, dense, appressed black pile on disc, longer, sparser, more erect yellow-white pile laterally. Sternites greyish with pale pile.

Terminalia blackish; pile black. Epandrium (Fig. 123) wider than long; cerci about one-third as long as epandrium. Gonocoxites (Fig. 124) broadly rounded posteriorly, fused via a narrow hyaline strip; hypandrial element discrete. Outer style rather thick-bodied, irregularly shaped apically. Aedeagus (Fig. 125) with phallic part knifeblade-shaped; orifice at apex (Fig. 126); proximal part of phallus remarkably sharp-edged.

Female. As for male except as follows. Eyes separated by about 4.5X width of anterior ocellus. T5–7 with remarkably coarse, black setae.

Terminalia. S8 in face view (Fig. 254) with a transverse depressed area surrounded posterolaterally by a field of strong, anteromedially directed setae, in profile (Fig. 255) with a marked incurvation at middle. Third A1 seta about 5X as long as wide, blunt-tipped; 7 A1 setae per side. Longest A2 seta about twice as long as 3rd A1 seta; 7 A2 setae per side.

Dimensions. Body length 10–12 mm, wing 8.8–9.8 mm.

Type data. Holotype: male, MC, W of Staveley, *Nothofagus* forest, 2 December 1977, E.I. Schlinger (CISB).

Paratypes: 1 male, 1 female, Thames, Kauaeranga R., 29 November 1953 (NZAC); 1 male, TO, Mt Ruapehu, Whakapapa Camp, 12 January 1967, K.A.J. Wise (AMNZ); 1 male, TK, Mt Egmont, 17 January 1955, G.W. Ramsay (NZAC); 3 males, 3 females, WN, Akatarawa, river bed, 22 December 1935, J.T. Salmon (NMNZ); 2 males, 1 female, WN, Wellington, 4 December 1919, H. Hamilton (NMNZ); 2 males, 1 female, SD, Opouri, 15 January 1969, J.S. Dugdale (NZAC); 1 female, MB, Pelorus Bridge Scenic Reserve SW of Havelock, 19 November 1977, E.I. Schlinger (CISB); 1 female, NN, Anisced Valley, 1–4 December 1923, A. Tonnoir (NZAC); 1 male, 1 female, NN, Oparara, November 1957, J.I. Townsend (NZAC); 3 males, 2 females, NN, Luna Hut, Karama R., 10 December 1972, A.K. Walker (NZAC); 4 females, NN, Crow R. Hut, Upper Karama R., 17–20 December 1972, A.K. Walker (NZAC); 1 female, NN, Owen R., 20 November 1957, E.S. Gourlay (NZAC); 2 females, BR, Reefton, Inangahua R. bed, 1 December 1969, J.S. Dugdale (NZAC); 6 males, 18 females, same data as holotype (CISB, NZAC, ZMKD).

— / CL, TO, TK, WN / SD, MB, NN, BR, MC / —

Anabarhynchus limbatinervis Kröber

Figures 111–113, 250, 251

limbatinervis Kröber, 1932: 133 (*Anabarrhynchus*). Holotype female, New Zealand.

Male. Head. Eyes separated in front of anterior ocellus by 3.2–3.4X its width. Frons above brown to brown-grey, below pure white-grey, or entirely grey tomentose, clearly protruding over most of its length; pile black, erect; most setae longer than scape. Face bare. Scape pale greyish; flagellum blackish; terminal flagellar segments together more than half as long as 1st segment. Occiput with 20–25 black macrosetae on either side. Pile of lower occiput and genae whitish. Palpi yellow-brown.

Thorax. Macrosetae: np 3 or 4, sa 2, pa 1, dc 0, sc 2; all setae black, strong. Mesonotum extensively dark grey-brown tomentose with 5 darker, brown-black, irregular stripes and with narrow strips of pure grey tomentum (in male from Banks Peninsula pale grey with 5 narrow brown stripes). Pile long, erect, black, with pale setae intermixed laterally and posteriorly. Scutellum dark brown (in Banks Peninsula male greyish with disc dark brown); pile long, pale. Prosternal furrow and posterior surface of middle coxae with pile; sternopleura without pile. Pleura and coxae greyish tomentose; mesopleura brownish tinged.

Legs. Fore and middle femora without macrosetae (but one specimen with 1 av on one side); hind femora with 1 av and 1 pv. Femora and tibiae grey-black. Pile of hind femora uniform, pale, moderately long, appressed to semi-erect.

Wings grey-brown with extensive dark brownish streaks along veins, especially distinctly developed around discal cell; stigma and veins brown-black. Halteres yellow-brown.

Abdomen. Tergites silvery white-grey tomentose; T2 and T3 with small areas of brown tomentum anterolaterally; pile whitish, moderately long. Sternites greyish with pale pilosity.

Terminalia greyish with pale setae. Epandrium (Fig. 111) characteristically narrowed posteriorly, forming a heart-shaped sclerite; cerci small. Gonocoxites (Fig. 112) with a finger-shaped extension, fused for some distance with each other and with hypandrial element. Outer style slender-bodied, with apex rounded. Aedeagus (Fig. 113) of a generalised type.

Female. As for male except as follows. Eyes separated by 5–6X width of anterior ocellus. Frons markedly protruding in lateral view; setae not longer than scape. Occiput with 15–20 macrosetae on either side. Pale grey stripes on mesonotum more distinct. T2–5 dull brown-black on more than anterior half; posterior parts thinly white-grey tomentose.

Terminalia. S8 in face view (Fig. 250) with a very weak impression, in profile (Fig. 251) with a slight incurvation

near middle; pile weak, sparsely distributed on most of surface. Third A1 seta about 4X as long as wide, blunt-tipped to slightly spatulate; 6 A1 setae per side. Longest A2 seta about 1.8X as long as 3rd A1 seta; 6 A2 setae per side.

Dimensions. Body length 6–7 mm, wing 5.3–6.1 mm.

Type data. Kröber described *A. limbatinervis* from a female specimen originating from Ohakune, RI. The holotype (BMNH) is in perfect condition. A male and a female in the BMNH, both labelled "Ohakune, XI. 1923, T.R. Harris", were probably collected along with the type specimen, but as Kröber described only the female sex these cannot be accorded paratypic status with any confidence.

Material examined. Holotype female, plus 12 non-type examples: 1 male, 1 female, TO, Taupo, lake shore, 11 Nov 1934, J.S. Armstrong (NZAC); 1 male, TO, Taupo, 4 Dec 1935, J.S. Armstrong (NZAC); 1 male, TO, Tokaanu, 22 Nov 1911 (NMNZ); 1 male, 1 female, RI, Ohakune, Nov 1923, T.R. Harris (BMNH); 1 female, HB, Puketitiri, 27 Nov 1934, J.S. Armstrong (NZAC); 1 male, HB, Hastings, Bridge Pa, 10 Feb 1981, T.H. & J.M. Davies (NZAC); 1 female, NN, Aniseed Vly, 1–4 Dec 1923, A. Tonnoir (NZAC); 1 male, 1 female, MC, Banks Pen., Little River, 13 Dec 1977, E.I. Schlinger (CISB); 1 male, FD, Pcm-broke, 23 Dec 1923 (AMNZ).

— / TO, RI, HB / NN, MC, FD / —

Anabarhynchus longepilosus new species

Figures 127–129, 260, 261

Male. Head. Eyes separated in front of anterior ocellus by 4.3–4.5X its width. Frons brownish (above) to greyish (below) tomentose, markedly protruding over entire length; pile long, black; setae up to twice as long as scape. Scape greyish; flagellum blackish; terminal flagellar segments together about half as long as 1st segment. Face bare. Occiput with over 50 black macrosetae on either side; lower setae hair-like. Pile of lower occiput and genae whitish. Palpi brown-grey.

Thorax. Macrosetae: np 4 or 5, sa 2 or 3, pa 1, dc 2–4, sc 3–5; all setae black, long, relatively weak. Mesonotum dull brown-black, on disc with an indistinct stripe of golden-grey tomentum, laterally greyish; pile black, long. Scutellum grey-brown on disc, paler grey along margin; pile pale, long. Prosternal furrow with long pile; sternopleuron without pile; posterior surface of middle coxae with a little pile. Pleura and coxae greyish.

Legs. Fore femora with 0–3 av macrosetae; middle fem-

ora without macrosetae; hind femora with 1 or 2 av and 1 pv. Femora greyish black. Pile on ventral surface of hind femora erect, black, with some basal setae as long as femoral width, on dorsal surface a mixture of whitish and black setae. Fore tibiae brown-black to nearly black apically; middle and hind tibiae paler brownish, apically blackish.

Wings grey-brown hyaline, with veins and stigma brownish. Halteres brownish to brown-black.

Abdomen. T2–5 with brown-black anterior bands occupying slightly more than half tergal length; posterior and lateral parts greyish tomentose; pile black on anterior bands, pale on remainder. Sternites greyish with pale pile.

Terminalia blackish with black pile. Epandrium (Fig. 127) 1.5X as wide as long; cerci rather coarse, about half as long as epandrium. Gonocoxites (Fig. 128) partly fused; hypandrium remarkably discrete; bridge to dorsal apodeme of aedeagus well developed. Outer style moderately thick-bodied, blunt-tipped. Aedeagus (Fig. 129) of a generalised type.

Female. As for male except as follows. Eyes separated by 5–6X width of anterior ocellus. Frontal pile shorter, with setae about as long as scape. Occiput with 25–30 macrosetae on either side. Mesonotum with more extensive yellow-grey tomentum. Prosternal furrow frequently without setae or with at most 2 pale setae.

Terminalia. S8 in face view (Fig. 260) with a moderately deep depression for most of sternal width, in profile (Fig. 261) with distinct incurvation around middle; pile long, unmodified, with setae mostly anteriorly directed. Third A1 seta about 4X as long as wide, blunt-tipped; 8 A1 setae per side. Longest A2 seta about twice as long as wide; 7 A2 setae per side.

Dimensions. Body length 11–14 mm, wing 9.6–10.8 mm.

Type data. Holotype: male, FD, Turret Range, West Arm, Manapouri, 4000' [1200 m], 16 January 1970, J.S. Dugdale (NZAC).

Paratypes: 1 female, FD, L. Manapouri, 4000' (1200 m), ? date, S. Lyndsay (BMNH); 2 females, FD, Turret Ra., Manapouri, 3500–4150' (1050–1245 m), 9 January 1970, J.S. Dugdale (NZAC); 1 male, FD, Turret Ra., Manapouri, Wolfburn Flats, 3200' (960 m), 10 January 1970, J.S. Dugdale (NZAC); 1 female, FD, Turret Ra., West Arm, Manapouri, 3500–4150' (1050–1245 m), 12 January 1970, J.S. Dugdale (NZAC); 1 female, same data as holotype; 1 female, FD, Mt Cleughearn, 13 January 1916 (NZAC); 1 male, FD, Cleughearn, 3500' (1050 m), 22 January 1914, ? coll. (NZAC).

— / FD / —

Anabarhynchus longipennis Kröber

Figures 130–132, 258, 259

longipennis Kröber, 1932: 135 (*Anabarhynchus*). Holotype male, New Zealand.

Male. Head. Eyes separated in front of anterior ocellus by 2.6–2.8X its width. Frons grey to grey-brown tomentose, slightly protruding in lateral view; pile black; longest setae as long as scape. Face bare. Scape greyish; flagellum blackish; terminal flagellar segments together about one-third as long as 1st segment. Occiput with 40–45 black macrosetae on either side. Pile of lower occiput and genae whitish. Palpi brownish yellow.

Thorax. Macrosetae: np 4 or 5, sa 2, pa 1, dc 1 or 2, sc 2; all setae black, strong. Mesonotum greyish tomentose, with 5 more or less distinct grey-brown stripes; pile composed of mixed black and pale setae, the latter dominating laterally and posteriorly. Scutellum grey-brown on disc, pale greyish along margin; pile whitish. Prosternum with pile in central depression; sternopleura and posterior surface of middle coxae without pile. Pleura and coxae pale greyish tomentose.

Legs. Fore and middle femora usually without macrosetae, or fore femora rarely with 1 weak av; hind femora with 1 weak av and 1 pv. Femora with ground coloration yellow-brown, usually more or less infuscated with grey tomentum, especially dorsally and apically. Tibiae yellow-brown. Pile of hind femora uniform, rather long (about half femoral width), pale, semi-erect.

Wings grey-brown hyaline; veins and stigma brown-black. Halteres with knob brown-black.

Abdomen. Tergites greyish; T₂–5 with paired, ill marked, blackish anterior areas; pile short, black on blackish areas, whitish on remainder. Sternites greyish, sometimes more or less distinctly yellow-brown translucent; pile whitish.

Terminalia brownish; pile yellowish and blackish. Epandrium (Fig. 130) wider than long, suddenly constricted at middle; cerci about one-third as long as epandrium. Gonocoxites (Fig. 131) simply rounded posteriorly, fused together, forming a synsclerite; hypandrial element a minute strip fused with synsclerite. Outer style moderately thick-bodied, sharply pointed; inner style with a small, dentate dorsal process. Aedeagus (Fig. 132) with phallic part long, curved, strongly anteriorly directed.

Female. As for male except as follows. Eyes separated by 3.0–3.6X width of anterior ocellus. Femora usually more extensively tomentose; av macrosetae more often present on fore and middle femora. Abdomen darker; T₂–4 extensively blackish, with narrow, greyish tomentose posterior borders; lateral areas greyish tomentose, often more or less brownish translucent.

Terminalia. S8 in face view (Fig. 258) subrectangular, without a depression, but with lateral rows of medially directed setae, in profile (Fig. 259) straight. Third A1 seta about 5X as long as wide, blunt-tipped; 8 A1 setae per side. Longest A2 seta about 2.5X as long as 3rd A1 seta; 7 or 8 A2 setae per side.

Dimensions. Body length 7–10 mm, wing 7.7–8.9 mm.

Type data. The holotype male (BMNH) is in good condition. It carries, among others, a label "New Zealand / J. Muggridge"; in the description the type locality is given as Wellington.

Material examined. Holotype male, plus 25 non-type examples (11 males, 14 females; AMNZ, BMNH, LCNZ, NZAC, ZMKD).

— / ND (Poor Knights Is), AK, CL (Little Barrier I.), TO, WN / SD (Stephens I., Trio I.), NN, BR, MC / —

Remarks. *A. longipennis* is easily recognised by the combination of presence of prosternal pile and yellow-brown colour of femora. It is externally similar to *A. femoralis*, which however lacks prosternal pile and has a much longer, very erect pile on the ventral surface of the hind femora. There are also genital differences between the two species (see illustrations).

Anabarhynchus macfarlanei new species

Figures 133–135, 262, 263

Male. Head. Eyes separated in front of anterior ocellus by 3.7X its width. Frons grey to brown-grey tomentose, moderately protruding in lower half; pile black, as long as scape. Face bare. Scape grey-black; flagellum black; terminal flagellar segments together about two-thirds as long as 1st segment. Occiput with about 45–50 strong black macrosetae on either side. Pile of lower occiput and genae whitish. Palpi yellowish.

Thorax. Macrosetae: np 5, sa 2, pa 1, dc 2, sc 2; all setae black. Mesonotum pale grey-brown tomentose, darker grey in a broad median band; 7 dark brown stripes or series of longitudinal spots. Mesonotal pile moderately long, blackish. Scutellum dark brown on disc, greyish along posterior margin; pile mainly whitish; black setae intermixed on disc. Prosternal furrow and sternopleura without pile; posterior surface of middle coxae with a little whitish pile. Pleura and coxae grey tomentose.

Legs. (Forelegs missing.) Middle femora without macrosetae; hind femora with 1 av and 1 pv. Middle and hind

femora yellow-brown, with dorsal surface towards apices gradually blackened. Pile on dorsal surface of hind femora composed of short, stiff, black setae and longer, semi-scaly, appressed, whitish, hair-like setae, on ventral surface long, erect, whitish; some setae as long as femoral width. Tibiae brownish, clearly darker than yellowish parts of femora.

Wings grey-brown hyaline, with very indistinct traces of darker streaks along veins; veins brown-black; stigma dark brownish. Halteres blackish.

Abdomen. In dorsal view tergites appearing dull black with yellow-red posterolateral areas, in frontal view grey tomentose. Sternites extensively greyish tomentose. Abdominal pile nearly all whitish; some black appressed setae on disc of tergites.

Terminalia mostly brownish, but epandrium with black pile and gonocoxites with pale pile. Epandrium (Fig. 133) very short relative to width, about twice as wide as long; cerci about as long as epandrium. Gonocoxites (Fig. 134) fused for a short distance posterior to the reasonably discrete hypandrium. Outer style with a sharp tooth some distance from the sharp apex. Aedeagus as in Fig. 135; phallic part with proximal section nearly straight and of nearly even width (cf. *neglectus*).

Female. As for male except as follows. Eyes separated by about 4x width of anterior ocellus. Frontal pile weaker, shorter. Occiput with fewer macrosetae. Thoracic macrosetae: 6 np on either side, and 3 sa (not 2) on one side. Halteres with knob not quite as dark as in male, but at least brownish black on convex upper side. Fore femora with 2 av macrosetae. Abdomen appearing brownish with a double row of roundish, greyish spots.

Terminalia. S8 in face view (Fig. 262) with about 12 setae on either side, arranged in posterolateral corners, in profile (Fig. 263) with a very deep, narrow, saddle-shaped depression at posterior third. Third A1 seta about 6x as long as wide, blunt-tipped; 7 A1 setae per side. Longest A2 seta about 2.4x as long as 3rd A1 seta; 6 A2 setae per side.

Dimensions. Body length 10.0–10.4 mm, wing 8.9–9.5 mm.

Type data. Holotype: male, NC, Waipara Co., Nape Nape, 16 November 1974, R.P. Macfarlane (NZAC).

Paratypes: 1 female, SD, Stephens I., Cook Strait, 15–19 December 1956, G.W. Ramsay (NZAC).

Material examined. Type specimens only.

— / SD, NC / —

Anabarhynchus major new species

Figures 136–139, 264, 265

Male. Head. Eyes separated in front of anterior ocellus by about 2.5x its width. Frons grey-brown to dark brown tomentose, slightly protruding in lower part; pile black, long, with many setae exceeding length of scape. Face bare. Scape grey-black; flagellum blackish; terminal flagellar segments together about two-thirds as long as 1st segment. Occiput with about 50 strong black macrosetae on either side. Pile of lower occiput and genae whitish. Palpi dirty yellowish.

Thorax. Macrosetae: np 4–6, sa 2, pa 1, dc 1 or 2, sc 2; all setae black. Mesonotal pattern dominated by 3 broad grey-brown bands, separated by grey-yellow tomentose stripes. Mesonotal pile mainly blackish, rather short; many longer brownish setae intermixed anteriorly, laterally, and posteriorly. Scutellum brown-black; posterior margin greyish; pile pale brownish. Prosternal furrow, sternopleura, and posterior surface of middle coxae without pile. Pleura and coxae white-grey tomentose.

Legs. Fore femora with 1 av macroseta; middle femora with 3 or 4 rather weak pv; hind femora with 1 av and 1–3 rather weak pv. Femora yellow-brown; fore femora darkened on dorsal surface over entire length; middle and hind femora slightly darkened dorsally at extreme apices. Pile of hind femora nearly all whitish, but short, black setae intermixed dorsally with semi-scaly whitish setae; length of ventral pile one-quarter to one-third of femoral width. Tibiae yellow-brown.

Wings grey-brown, most intensely coloured along veins; proximal areas of cells sc and r₁ hyaline; stigma indistinctly darker brownish. Halteres yellowish.

Abdomen. Tergites grey-black on disc, with mid-anterior part of each appearing darker owing to short, black, appressed pile; lateral areas yellow-red translucent through a thin grey tomentum; sternites similarly yellow-red translucent through greyish tomentum; pile whitish.

Terminalia brownish yellow; epandrium with mainly blackish pile; gonocoxites with pale pile. Epandrium (Fig. 136) about as long as its maximal width; cerci about one-third as long as epandrium. Gonocoxites (Fig. 137) forming well marked zones of fusion with hypandrial element, less extended (cf. *megalopyge*, Fig. 141). Outer style with apex heavy, sharp; inner style (Fig. 138) with a low but rather sharp tooth on dorsal surface. Aedeagus (Fig. 139) with phallic part moderately long, much wider than in *megalopyge* (cf. Fig. 143).

Female. As for male except as follows. Eyes separated by 3–4x width of anterior ocellus. Frontal pile shorter, with only a few setae as long as scape. One paratype with 3 dc

on one side only. Tergites shiny blackish on disc; postero-lateral corners of T2–5 white-grey tomentose; T6+7 red-yellow on more extensive posterolateral areas, and T5 also sometimes with slight red-yellow coloration. T2–4 with black, appressed pile on blackish areas, whitish pile on greyish areas; lateral pile on T4 and pile on T5–7 black, more erect. Sternites greyish; S6+7 sometimes more red-yellow translucent, and this coloration sometimes also appearing on lateral parts of other sternites and on over-turned margins of tergites.

Terminalia. S8 in face view (Fig. 264) with a large, circular, slightly demelanised and depressed area, and with setae arranged mainly outside that area, in profile (Fig. 265) nearly straight. Third A1 seta about 5X as long as wide, blunt-tipped; 6 or 7 A1 setae per side. Longest A2 seta about 2.5X as long as 3rd A1 seta; 7 or 8 A2 setae per side.

Dimensions. Body length 9.6–12.3 mm, wing 8.4–11.8 mm.

Type data. Holotype: male, BR, Lake Rotoiti, 610 m, 16 January 1976, to light, A.K. Walker (NZAC).

Paratypes: 1 male, 2 females, same data as holotype (NZAC, ZMKD); 1 female, BR, Nelson Lakes N.P., Mt Robert, 4000' [1200 m], 2 February 1972, swept ex tussock, R.A. Harrison (LCNZ); 1 male, 1 female, OL, Queenstown, Ben Lomond, 1000 m, 1 January 1990, A.C. Harris (OMNZ).

Material examined. Type series only.

— / BR, OL / —

Anabarhynchus maori Hutton

Figures 16–18, 22, 144–146, 266, 267

maori Hutton, 1901: 25 (*Anabarhynchus*). Lectotype female, New Zealand.

frontalis Kröber, 1932: 137 (*Anabarhynchus*). Holotype male, New Zealand.

Male. Head. Eyes separated in front of anterior ocellus by about 2.8X its width. Frons markedly protruding from about middle, subshiny black on upper two-thirds, white-grey tomentose on lower third, with a sharp line of demarcation; pile black; some setae about as long as scape. Face bare. Scape grey-black; flagellum black; terminal flagellar segments together about one-third as long as 1st segment. Occiput with about 35–40 strong black macrosetae on either side. Pile of lower occiput and genae whitish. Palpi brown-black.

Thorax. Macrosetae: np 3–5, sa 2, pa 1, dc 2 or 3, sc 2; all setae black. Mesonotum with 3 shiny brown-black

bands separated by narrower white-grey stripes; lateral mesonotal areas white-grey tomentose. Mesonotal pile moderately long, mainly black, with whitish setae predominant laterally and posteriorly. Scutellum greyish with disc brown-black; pile whitish. Prosternal furrow, sternopleura, and posterior surface of middle coxae without pile. Pleura and coxae white-grey tomentose.

Legs. Fore femora with 1 or 2 av macrosetae at middle; middle femora with 1 pv; hind femora with 1 or 2 av and 1 pv. Femora blackish, only slightly tomentose. Pile on ventral surface of hind femora shorter than one-third of femoral width, composed of whitish and blackish hair-like setae. Tibiae brown-black to black.

Wings dark greyish hyaline, with veins and stigma brown-black. Halteres blackish.

Abdomen. Tergites with shiny black anterior bands reaching posterior margin in middle, strongly contrasting with white-grey tomentose postrolateral areas. Pile of dark areas black, appressed, that of white-grey areas white, semi-erect. Sternites greyish with white-yellow pile.

Terminalia blackish with black pile. Epandrium (Fig. 144) about as wide as long, constricted from about middle; cerci long, sharply pointed. Gonocoxites (Fig. 145) connected via a hyaline area; hypandrium discrete, with a few setae. Outer style with a minute subapical thorn. Aedeagus (Fig. 146) with phallic part of even width for some distance, strongly curved, ending in a sharp apex.

Female. As for male except as follows. Eyes separated by 3.1–3.2X width of anterior ocellus. Lower frons more grey-brown tomentose. Wings more grey-brown. Abdominal tergites with more extensive blackish coloration and nearly exclusively blackish pile.

Terminalia. S8 in face view (Fig. 268) semicircular, with 3 small, oval, depressed, slightly demelanised areas, in profile (Fig. 267) with a slight incurvation of posterior half and with remarkably long erect setae on anterior half. Third A1 seta about 6X as long as wide, gradually tapering, moderately blunt-tipped; 7 or 8 A1 setae per side. Longest A2 seta about 1.8X as long as 3rd A1 seta; 7 A2 setae per side.

Dimensions. Body length 9–10 mm, wing 8.6–9.3 mm.

Type data. The type material (CMNZ) consists of one female and one male. The female syntype is labelled "Wellington or Christchurch", "*Anabarhynchus maori* Hutt. / F.W. Hutton det.", "Type" and "I. 513". The male bears the same four labels, with the exception of "Paratype" instead of "Type". These type labels are later additions probably intended to indicate what should be considered lectotype and paralectotype. As these have not been for-

mally published, I hereby designate the female labelled "Type" as lectotype; it has been labelled accordingly. The male is another species, *Anabarhynchus latus*.

The holotype of *frontalis* (BMNH) is a male with the data "Ohakume" [sic], 2-5 December 1919.

Material examined. Lectotype of *maori*, holotype of *frontalis*, and 4 non-type examples: 1 male, New Zealand, bred from larva, Nov 1885, G.V. Hudson (BMNH, 1923-323); 1 female, WN, Wellington, 23 Jan 1911, F.W. Hutton (BMNH, 1911-503); 1 male, WN, Wilton's Bush, 29 Dec 1922, G.V. Hudson (NMNZ); 1 male, MC, Kaituna Vly, 17 Oct 1973, with pupal skin, R.O. Welsh (LCNZ).

— / RI, WN / MC / —

Remarks. Hudson (1950, p. 63) describes and illustrates the larva under the name *Anabarhynchus frontalis*. He found it "amongst powdery decayed wood, or under logs in an advanced stage of powdery decay." His notebook entry No. 157a indicates that the larva was found during November [18]85. The male in the BMNH was probably bred from this larva or from one collected concurrently. The pupal exuviae is illustrated in Fig. 16-18 and 22.

The statement by Hudson (1950) that *Anabarhynchus frontalis* was identified as *Saropogon viduus* in his 'Elementary Manual of N.Z. Entomology' (1892, p. 55) is evidently wrong, because judging from the description and illustrations (plate VI: 4, 4a, and 4b) the taxon treated as *Saropogon viduus* is identical with *Megathereva atritibia*.

Anabarhynchus megalopyge new species

Figures 140-143, 270, 271

Male. Head. Eyes separated in front of anterior ocellus by 2.1-2.5x its width. Frons protruding in lower half, grey-brown to brown tomentose; pile black; some setae as long as scape. Face bare. Scape pure grey; flagellum blackish; terminal flagellar segments together half as long as 1st segment. Occiput with about 50 strong black setae on either side. Lower occiput and genae with yellowish pile. Palpi yellow-brown.

Thorax. Macrosetae: np 4-7, sa 2, pa 1, dc 2, sc 2; all setae black, strong. Mesonotum dark grey-brown tomentose, with 3 darker brown stripes; pile short, black; many golden-brownish setae present laterally and posteriorly. Scutellum dark brown on disc, greyish along margin; pile yellow-brown. Prosternal furrow and sternopleura without pile; posterior surface of middle coxae with some pile. Pleura and coxae white-grey tomentose.

Legs. Fore femora with 1 or 2 av macrosetae and 1 or 2 pv; middle femora with 3 or 4 pv; hind femora with 1 or 2

av and 2 pv. Femora yellow-brown, blackened dorsally over distal third to half. Tibiae brownish to dark brownish. Pile of hind femora short, pale, semi-erect to semi-scaly; black setae present on blackened dorsal area.

Wings brownish hyaline; veins and stigma dark brown. Halteres dark brownish, especially on dorsal, convex side of knob.

Abdomen. Disc of tergites white-grey tomentose, with a median band of darkened triangular areas; lateral parts in certain views reddish yellow with a slight tomentum. Pile mainly whitish, yet black and very short on dark areas. Sternites reddish yellow with whitish pile.

Terminalia brownish yellow; pile composed of whitish and blackish setae. Epandrium (Fig. 140) narrower than long; cerci half as long as epandrium, sharply pointed. Gonocoxites very broadly rounded posteriorly, with hypandrial element (Fig. 141) forming a ventral synsclerite (in fact very weak zones of fusion are present, but considering the distinct zones of fusion in many other species it would be misleading to draw these). Outer and inner styles relatively short, the latter gently curved in profile (Fig. 142). Aedeagus (Fig. 143) with phallic part extremely long and slender.

Female. As for male except as follows. Eyes separated by about 3x width of anterior ocellus. Frontal pile about half as long as scape. Tergites with disc blackish, in dorsal view with narrow lateral strips of greyish tomentum on T2-4 and wider strips on T5-7, these strips usually clearly red-yellow translucent.

Terminalia. S8 in face view (Fig. 270) semicircular, with middle part slightly depressed and devoid of setae, in profile (Fig. 271) with a moderate incurvation at middle; pile of posterior lobe sparse; setae of mid-lateral part long, erect. Third A1 seta about 6x as long as wide, sharp-tipped; 7 A1 setae per side. Longest A2 seta about twice as long as 3rd A1 seta; 6 or 7 A2 setae per side.

Dimensions. Body length 10-12 mm, wing 9.5-10.8 mm.

Type data. Holotype: male, TO, Whirinaki State Forest, Mangawiri Basin, 15 December 1965, J.S. Dugdale (NZAC).

Paratypes: 1 male, TO, Taupo, Tauhara, 27 December 1931, J.S. Armstrong (NZAC); 3 males, 3 females, HB, Puketitiri, Little Bush, 28 November to 10 December 1981, T.H. & J.M. Davies (NZAC, ZMKD); 3 females, HB, Puketitiri, Little Bush, 7 February 1988, 10 March 1988, and 27 November 1989, T.H. & J.M. Davies (NZAC); 1 female, SD, Maud I., 3-5 December 1979, G.W. Gibbs (NMNZ); 1 male, BR, St Arnaud, 12 December 1980, J.S. Noyes (NZAC).

Material examined. Type series only.

— / TO, HB / SD, BR / —

Anabarhynchus microphallus new species

Figures 150–152, 268, 269

Male. Head. Eyes separated in front of anterior ocellus by 3.3X its width. Frons slightly protruding below; upper half brown-grey tomentose, lower half white-grey tomentose; pile black, rather short; setae shorter than scape. Face bare. Scape grey-black; flagellum blackish; terminal flagellar segments together shorter than half length of 1st segment. Occiput with about 50 black macrosetae on either side. Pile of lower occiput and genae whitish. Palpi yellowish.

Thorax. Macrosetae: np 4, sa 2, pa 1, dc 2, sc 2; all setae black. Mesonotum patterned: ground colour of tomentum grey-brown; a dark brown median band occupying about one-fourth of mesonotal width, not reaching posterior margin; laterally 2 further pairs of dark brown bands, both interrupted by grey-brown tomentum, resulting in a series of 3 spots. Mesonotal pile moderately long, composed of blackish and pale brownish setae. Scutellum greyish, only slightly brownish on disc; pile whitish. Prosternal furrow, sternopleura, and posterior surface of middle coxae without pile. Pleura and coxae white-grey tomentose.

Legs. Fore femora without macrosetae or with 1 small av; middle femora without macrosetae or with 1 small pv; hind femora with 1 av and 1 pv. Femora yellow-brown, indistinctly darkened at apices. Pile of hind femora nearly exclusively whitish, but with a few black setae intermixed; semi-scaly hair-like setae present on dorsal surface; pile of ventral surface as long as half femoral width. Tibiae colourous with femora, not darkened at apices.

Wings greyish brown with indistinctly darker streaks along veins; proximal parts of cells sc and r_1 whitish hyaline; stigma brown-black. Halteres dirty yellowish, with stem darkened.

Abdomen. T2–6 with dull darker anterior bands; posterior parts red-yellow; entire lateral areas in dorsal view appearing white-grey tomentose, in lateral view appearing red-yellow. Sternites red-yellow, in part covered with thin white-grey tomentum. Pile whitish throughout.

Terminalia yellowish with pale pilosity. Epandrium (Fig. 150) about as wide as long; cerci shorter than half length of epandrium. Gonocoxites (Fig. 151) with very sparse pile, connected posteriorly via a short, wide bridge of sclerotisation separated from the narrowly triangular, rather discrete hypandrium by a hyaline area. Outer style short, narrow, sharp-pointed. Aedeagus (Fig. 152) with phallic part short, only slightly curved, rapidly narrowing.

Female. As for male except as follows. Eyes separated by 4.3X width of anterior ocellus. Femora dull grey-brown, appearing darker. Abdomen with more distinct blackish anterior bands.

Terminalia. S8 in face view (Fig. 268) without incurvation into anterior margin, in profile (Fig. 269) with a moderately deep incurvation on posterior half; pile very restricted, short, weak. Third A1 seta about 10X as long as wide, sharp-pointed; 7 A1 setae per side. Longest A2 seta about 1.3X as long as 3rd A1 seta; 6 or 7 A2 setae per side.

Dimensions. Body length about 8 mm, wing 6.4–6.8 mm.

Type data. Holotype: male, ND, Spirits Bay, 1 February 1977, A.K. Walker (NZAC).

Paratypes: 1 male, ND, Uretiti, N of Waipu R., beach, 3 February 1988, R.F. Gilbert (AMNZ); 1 female, ND, Rarawa Beach, Ngataki, N of Houhora, on white sand, 9 March 1967, K.A.J. Wise (AMNZ).

Material examined. Type series only.

— / ND / —

Anabarhynchus monticola new species

Figures 147–149, 272, 273

Male. Head. Eyes separated at narrowest point by about width of anterior ocellus. Frons not protruding, brown-grey tomentose above, white-grey tomentose below; pile entirely black, or some lower setae pale; setae shorter than scape. Face laterally with some relatively long, pale and/or black setae. Scape white-grey; flagellum blackish; terminal flagellar segments together about two-thirds as long as 1st segment. Occiput with 40–45 strong black macrosetae on either side. Pile of lower occiput and genae whitish. Palpi greyish.

Thorax. Macrosetae: np 4, sa 2, pa 1, dc 1, sc 2. Mesonotum and scutellum practically uniformly dark greyish, with a brownish tinge anteriorly; pile rather short, composed of black and pale setae. Prosternal furrow and sternopleura without pile; posterior surface of middle coxae with whitish pile. Pleura and coxae white-grey tomentose.

Legs. Fore femora with 1–3 pd macrosetae and 1–3 av; middle femora without macrosetae or with 1 av and 1 or 2 pv; hind femora with 2 or 3 av and 1 or 2 pv. Femora and tibiae grey-black. Pile of hind femora exclusively whitish, rather long, semi-appressed.

Wings rather dark grey-brown hyaline; veins and stigma brown-black. Halteres blackish.

Abdomen uniformly whitish grey tomentose and whitish pilose.

Terminalia grey-black with whitish pile. Epandrium (Fig. 147) about as long as wide; cerci slender, about half as long as epandrium. Gonocoxites (Fig. 148) fused for a long distance, characteristically abruptly truncate distally; hypandrial element rudimentary. Styles and aedeagus (Fig. 149) of a generalised type.

Female. As for male except as follows. Eyes separated by about 5x width of anterior ocellus. Femoral macrosetae: fore femora with 6–8 irregularly arranged pd, 4 strong av, and 2 weaker pv; hind femora with 4 very strong av and 2 pv. T2–4 dull brown-black anteriorly, pale greyish tomentose posteriorly and laterally; pile mostly black.

Terminalia. S8 in face view (Fig. 272) with a slight depression of mid posterior part, in profile (Fig. 273) straight; pile uniform, rather weak but long, mostly anteriorly directed. Third A1 seta about 6x as long as wide, blunt-tipped; 9 A1 setae per side. Longest A2 seta about as long as 3rd A1 seta; 6 A2 setae per side.

Dimensions. Body length 10–11 mm, wing 8.5–9.0 mm.

Type data. Holotype: male, TO, Tongario [sic], January 1970, K. Spitzer (NZAC).

Paratypes: 1 female, TO, Tongario [sic] National Park, 11 February 1973, H. Hayakawa (ZMKD); 2 males, TO, Mt Tongariro N.P., Mangatepopo Hut, 11 February 1973, K.M. Mason (LCNZ); 1 male, 1 female, TO, Mt Tongariro N.P., Mangatepopo–Chateau Track, 11 February 1973, R.A. Harrison & J.A. Timms (LCNZ); 1 male, TO, Mt Ruapehu, Whakapapaiti Strm, c. 1800' [540 m], 28 February 1969, K.A.J. Wise (AMNZ).

Material examined. Type series only.

— / TO / —

***Anabarhynchus nebulosus* Hutton**

Figures 156–158, 274, 275

nebulosus Hutton, 1901: 26 (*Anabarhynchus*). Holotype male, New Zealand.

Male. Head. Eyes separated in front of anterior ocellus by 2.5–2.6x its width. Frons slightly protruding in lower part, white-grey tomentose on upper half, the tomentum more or less brownish-tinged (and sometimes entirely cinnamon brown, as in holotype); pile pale yellowish or black, or composed of both yellowish and black setae; setae shorter than scape. Face bare. Scape greyish; flagellum blackish; terminal flagellar segments about 0.6x as long as 1st segment. Occiput with 35–40 strong black macrosetae on either side. Lower occiput and genae with whitish pile.

Palpi yellow-grey to grey.

Thorax. Macrosetae: np 4 or 5, sa 2, pa 1, dc 2 or 3, sc 2; all setae black, strong. Mesonotum ash-grey with 3 broad grey-brown bands marked with dark brown stripes; pile composed of short, erect, black setae restricted to centre of disc and appressed yellowish setae. Scutellum grey with disc dark brown; pile pale yellowish. Prosternal furrow, sternopleura, and posterior surface of middle coxae without pile. Pleura and coxae white-grey tomentose.

Legs. Fore femora with 1 or 2 pd macrosetae, 0 or 1 av, and 0–2 pv; middle femora with 1 or 2 pv; hind femora with 1 av and 1 pv. Femora grey-black. Pile of hind femora exclusively pale yellowish; setae about as long as half femoral width, appressed on dorsal surface, semi-erect on ventral surface. Tibiae brownish.

Wings whitish hyaline with 12 more or less distinct areas of brown-black microtrichia arranged in centre of cells; veins and stigma brown-black; a few minute setae present on dorsodistal section of R₁. Halteres with knob yellowish.

Abdomen pale greyish tomentose; pile moderately long, pale yellowish.

Terminalia brownish, with slight greyish tomentum and pale pilosity. Epandrium (Fig. 156) about 1.5x as wide as long; cerci about half as long as epandrium. Gonocoxites (Fig. 157) characteristically pointed and diverging, touching for only a short distance in midline; hypandrium discrete. Aedeagus (Fig. 158) with phallic part rather short, only slightly curved.

Female. As for male except as follows. Eyes separated by about 5x width of anterior ocellus. Dark brown stripes on mesonotum sometimes very indistinct.

Terminalia. S8 in face view (Fig. 274) with 2 squarish incurvations of posterior margin (posterior lobe seeming anteriorly displaced), with 2 rows of 7 or 8 anteromedially directed setae lying below the weaker, more numerous anterolaterally directed setae of posterior lobe and crossing them at approximately right angles, in profile (Fig. 275) with a marked incurvation around middle, forming a protruding 'nose' posteriorly. Third A1 seta about 6x as long as wide, blunt-tipped; 8 A1 setae per side. Longest A2 seta about 1.3x as long as 3rd A1 seta; 8 or 9 A2 setae per side.

Dimensions. Body length 8–10 mm, wing 6.8–7.7 mm.

Type data. Holotype: male, WN, Wellington, G.V. Hudson (CMNZ).

Material examined. Holotype, plus 33 non-type examples (18 males, 15 females; CISB, CMNZ, LCNZ, NZAC, ZMKD).

— / WI, WN / NN / —

Remarks. *A. nebulosus*, *A. completus*, *A. lacustris*, *A. tricoloratus*, and *A. westlandensis* form a clearly monophyletic group. Synapomorphic characters are: (a) the gonocoxites characteristically pointed and diverging; (b) the female S8 usually with two sets of crossing setae (cf. Fig. 274); (c) the wing cells usually with central areas of dark microtrichia; and (d) vein R_1 with minute setae on the dorsal surface.

These five species seem to be restricted to beaches, and show an allopatric distribution throughout New Zealand. *A. tricoloratus* is known from northern parts of the North Island. *A. lacustris* is so far recorded only from Lake Waikaremoana, in the eastern part of the North Island. *A. nebulosus* is known from three districts (Wanganui, Wellington, Nelson) around Cook Strait. *A. completus* is probably restricted to the east coast (Kaikoura, mid Canterbury) of the South Island. Finally, *A. westlandensis* occurs on the west coast of the South Island.

Anabarrhynchus neglectus Kröber

Figures 153–155, 276, 277

neglectus Kröber, 1932: 132 (*Anabarrhynchus*). Lectotype male, New Zealand.

thoracicus Kröber, 1932: 133 (*Anabarrhynchus*) new synonymy. Holotype male, New Zealand.

Male. Head. Eyes separated in front of anterior ocellus by 3.8–4.2x its width. Frons moderately protruding in lower half, brown-grey tomentose, with long black pile; most frontal setae as long as scape. Scape grey-black; flagellum blackish, frequently a little brownish basally on 1st segment; terminal flagellar segments together about half as long as 1st segment. Face bare. Occiput with about 45–50 strong black macrosetae on either side. Pile of lower occiput and genae white-yellow. Palpi yellowish.

Thorax. Mesonotum and scutellum with abundant strong black macrosetae: np usually 5–8 (in holotype of *thoracicus* 16/18), sa 2 or 3, pa 1 or 2, dc 2 or 3, sc 3 or 4. Mesonotum dark grey-brown tomentose, with 3 more or less marked darker brown stripes; traces of a further stripe more laterad. Mesonotal pile long, nearly exclusively blackish, but with whitish setae intermixed posteriorly. Scutellum dark brownish, with posterior margin greyish; pile long, whitish. Prosternal furrow and sternopleura without pile; posterior surface of middle coxae with some whitish pile. Pleura and coxae uniformly grey tomentose.

Legs. Fore femora without macrosetae or with a single av; middle femora without macrosetae; hind femora with 2 (or 3) av and 1 pv. Femora yellow-brown to yellow-red; fore femora extensively blackened on dorsoapical surface, middle femora not, and hind femora less extensively. Pile

of hind femora composed of whitish and black setae; dorsal surface with semi-scaly whitish setae; ventral surface with numerous erect, whitish, hair-like setae, the longest as long as femoral width. Tibiae yellow-brown, not darkened towards apex.

Wings uniformly brownish hyaline; veins brown-black; stigma indistinctly darker brown than wing. Halteres yellowish.

Abdomen. All tergites appearing subshiny blackish in strict dorsal view; lateral and posterolateral areas red-yellow covered with a thin whitish tomentum (this also distributed on lateral areas of black bands), resulting in a remarkably pinkish coloration; sternites similarly pinkish. Pile of tergal bands blackish, elsewhere whitish.

Terminalia red-brown with mainly blackish pilosity. Epandrium (Fig. 153) about 1.6x as wide as long; cerci about half as long as epandrium. Gonocoxites (Fig. 154) touching for a short distance posterior to the weakly delimited hypandrial element. Outer style with a sharp tooth some distance from irregular apex. Aedeagus (Fig. 155) with phallic part gently tapering from base to apex (cf. *macfarlanei*).

Female. As for male except as follows. Occiput with about 35 macrosetae on either side. Mesonotal pile shorter. Femora hardly blackened on dorsal surface. Terminal tergites yellow-red as follows: T5 in a narrow hind-marginal strip, T6 over posterior half, and T7 entirely; T5–7 with stiff black pilosity.

Terminalia. S8 in face view (Fig. 276) with pile remarkably restricted, in profile (Fig. 277) with a wide, deep incurvation; setae of posterior lobe as strong as those lateral to saddle-shaped depression of posterior half (all setae practically dorsoventrally directed, and thus difficult to draw in face view). Third A1 seta about 6x as long as wide, blunt-tipped; 7 A1 setae per side. Longest A2 seta about 2.3x as long as 3rd A1 seta; 7 or 8 A2 setae per side.

Dimensions. Body length 10.5–13.5 mm, wing 9.6–10.4 mm.

Type data. The type series of *A. neglectus* is (BMNH) comprises two males and a female, all in reasonably good condition. One male and the female are labelled "Arthur's P., 3400', 30.XII.22, J.G. Myers"; the second male is labelled "Ok. 10.1.20". All three specimens must be regarded as syntypes, and were labelled as such by Mr J.E. Chainey in 1981. The label data agree with those published by Kröber, but he seems to have seen additional specimens. I hereby designate the male from Arthur's Pass as lectotype, and have labelled it accordingly; it conforms to the original description.

A. thoracicus was described from a single male labelled "Arthur's Pass 8.I.1923". The holotype (BMNH) is in good condition. Its locality label accords with information given in the original description. The holotype has unusually abundant mesonotal and scutellar macrosetae (I have seen no other therevid with as many): there are 16 np on the left side and 18 on the right; 3 sa, 1 pa, 3 dc, and 4 sc (one of them weak). I nonetheless have no doubt that the holotype of *A. thoracicus* is an aberrant specimen of *A. neglectus*, and I consequently synonymise them.

Material examined. Lectotype of *neglectus*: male, NC-WD, Arthurs Pass, 3400' [1020 m], 30 December 1922, J.G. Myers (BMNH); paralectotypes: 1 female, same data as lectotype (BMNH), and 1 male, "Ok.", 10 January 1920 (BMNH). Holotype of *thoracicus*: male, NC-WD, Arthurs Pass, 3000' [900 m], 8 January 1923, J.G. Myers (BMNH).

Also 8 non-type examples: 1 female, NN, Mt Arthur TI [Tableland], 4500 ft (1350 m), 27 Dec 1921, A. Tonnoir (NZAC); 1 female, NN, Salisbury's Opng, 2500' [750 m], 14 Jan 1943, E.S. Gourlay (NZAC); 1 male, BR, St Arnaud Range, 5000' [1500 m], 1 Feb 1957, B.B. Given (NZAC); 1 female, BR, St Arnaud Range, near L. Rotoiti, 1460 m, sweeping tussock, 17 Jan 1976, A.K. Walker (NZAC); 1 male, 1 female, NC-WD, Arthurs Pass, Dec 1922, H. Hamilton (NMNZ); 1 male, 1 female, SC, Mt Peel, 5300' [1600 m], 7 Jan 1930, E.S. Gourlay (NZAC).

— / NN, BR, NC-WD, SC / —

Anabarhynchus nigrofemoratus Kröber

Figures 162–164, 280, 281

nigrofemoratus Kröber, 1932: 134 (*Anabarhynchus*).

Holotype female, New Zealand.

Male. Head. Eyes separated in front of anterior ocellus by 2.2–2.5x its width. Frons slightly protruding in lower part, grey to grey-brown tomentose, frequently with a pair of small brownish tomentose spots on midlateral area; pile black; setae about as long as scape. Scape grey-black; flagellum blackish; terminal flagellar segments together less than half as long as 1st segment. Occiput with 50–60 black macrosetae on either side. Pile of lower occiput and genae whitish. Palpi brownish.

Thorax. Macrosetae: np 4, sa 2, pa 1, dc 2, sc 2; all setae black, very strong relative to body size. Mesonotum greyish tomentose with 5 more or less distinct traces of dark brown-grey stripes. Mesonotal pile composed of rather long, erect black setae and short, more appressed whitish setae. Scutellum greyish; pile whitish. Prosternal furrow, sternopleura, and posterior surface of middle coxae without pile. Pleura and coxae greyish.

Legs. Fore femora with 1 av macroseta; middle femora without macrosetae or with 1 pv; hind femora with 1 or 2 av and 1 pv. Femora grey-black, only thinly tomentose. Pile on ventral surface of hind femora whitish and semi-erect, the setae up to half as long as femoral width, on dorsal surface appressed, semi-scaly, white-yellow. Tibiae yellow-brown.

Wings grey-brown hyaline; veins brownish to dark brownish; stigma indistinct, pale brownish. Halteres dark yellowish.

Abdomen white-grey tomentose; pile whitish.

Terminalia brownish, with a mixture of black and pale setae. Epandrium (Fig. 162) about as wide as long; pile very restricted; cerci small, oval. Gonocoxites (Fig. 163) with more or less distinct zones of fusion with each other and with hypandrial element. Outer style blunt-tipped; inner style with a remarkably strong tooth on dorsal surface. Aedeagus (Fig. 164) with phallic part long, of nearly even width, ending in a sharp apex.

Female. As for male except as follows. Eyes separated by 2.8–3.2x width of anterior ocellus. Frontal tomentum darker grey-brown; mesonotal stripes more distinct; tergites with blackish anterior bands.

Terminalia. S8 in face view (Fig. 280) with very restricted pilosity except on posterior lobe, in profile (Fig. 281) hardly incurved. Third A1 seta about 6x as long as wide, narrowly blunt-tipped; 6 or 7 A1 setae per side. Longest A2 seta about twice as long as 3rd A1 seta; 7 or 8 setae per side.

Dimensions. Body length 7–9 mm, wing 5.8–8.3 mm.

Type data. The holotype (BMNH) is a female, not a male as stated in the description, in good condition, labelled "Stephen's I, / 14.1.22 / R.J. Tillyard".

Material examined. Holotype, plus 17 non-type examples: 1 male, ND, Three Kings Is, Great I., 1 Mar 1963, E.S. Gourlay (NZAC); 1 male, 2 females, ND, Three Kings Is, Great I., Castaway Camp, Nov 1970, Ent. Div. Exp. (NZAC); 1 female, ND, Poor Knights Is, Tawhiti Rahi, 5 Dec 1980, swept around stagnant pool, M.F. Tocker (NZAC); 1 male, SD, Trio I., Cook Strait, 20 Dec 1954, G.W. Ramsay (NZAC); 1 male, SD, Stephens I., 9–12 Jan 1931, E.S. Gourlay (NZAC); 2 males, 1 female, SD, Stephens I., 14–28 Jan 1933, E.S. Gourlay (NZAC); 1 female, SD, Stephens I., 19–24 Jan 1946, E.S. Gourlay (NZAC); 3 males, 3 females, MC, Governors Bay, Banks Pen., J.F. Tapley Coll. (CMNZ, ZMKD).

— / ND / SD, MC / —

Anabarhynchus olivaceus new species

Figures 278, 279

Male. Unknown.

Female. Head. Eyes separated in front of anterior ocellus by about 5X its width. Frons yellow-grey tomentose above, white-grey tomentose below, in profile protruding over entire length; setae black, shorter than scape. Face bare. Scape white-grey; flagellum blackish; terminal flagellar segments together about half as long as 1st segment. Occiput with about 25 short black macrosetae on either side. Pile of lower occiput and genae whitish. Palpi brown-black.

Thorax. Macrosetae: np 4 or 5, sa 2, pa 1, dc 1, sc 2; all setae black. Mesonotal tomentum white-grey laterally and in 2 stripes separating 3 broad, olivaceous yellow-grey bands, the lateral ones interrupted at notopleural furrow, and with dark brown strips of tomentum on inner anterior part of lateral bands and on both sides of posterior part; pile short, black. Scutellum brown to grey-brown with short black pile. Prosternal furrow with pile; sternopleura and posterior surface of middle coxae without pile. Pleura and coxae white-grey tomentose; sternopleura with a yellow-grey fringe.

Legs. Fore and middle femora without macrosetae, or fore femora with 1 av; hind femora with 1 or 2 av and 1 pv. Legs blackish. Pile of hind femora very short, composed of pale and black setae.

Wings strongly maculated, with broad dark brown streaks along veins leaving centre of wing cells whitish hyaline; veins and stigma brown-black. Halteres yellow-brown.

Abdomen. T2-5 with marked brown-black anterior bands strongly contrasting with white-grey tomentose posterior parts; pile sparse, short, black on blackish areas, white on tomentose areas. Sternites thinly white-grey tomentose; pile whitish.

Terminalia. S8 in face view (Fig. 278) with short, very restricted pilosity, in profile (Fig. 279) straight. Third A1 seta about 4X as long as wide, blunt-tipped to slightly spatulate; 6 A1 setae per side. Longest A2 seta about 4.5X as long as 3rd A1 seta; 6 or 7 A2 setae per side.

Dimensions. Total length 8-9 mm, wing 6.8-7.0 mm.

Type data. Holotype: female, NC, Bealey River, 9 December 1958, E.S. Gourlay (NZAC).

Paratypes: 1 female, same data as holotype.

Material examined. Type specimens only.

— / NC / —

Remarks. *A. olivaceus* is clearly a sister-species of *A. limbatinervis*; it can be separated by its single pair of dorsocentral setae, blackish tibiae, and ornate mesonotal tomentum.

Anabarhynchus ostentatus new species

Figures 159-161, 284, 285

Male. Head. Eyes separated at narrowest by less than width of anterior ocellus. Frons grey to grey-brown tomentose, narrowly protruding below; pile black; setae shorter than scape. Face with a row of relatively strong setae. Scape grey-black; flagellum blackish; terminal flagellar segments together two-thirds to one-half as long as 1st segment. Occiput with about 30 black macrosetae on either side. Pile of lower occiput and genae whitish. Palpi grey-yellow or grey.

Thorax. Macrosetae: np 4 or 5, sa 2, pa 1, dc 1 or 2, sc 2; all setae black. Mesonotum and scutellum usually uniformly greyish, sometimes with very indistinct traces of 3 brownish bands; pile short, composed of black and pale setae. Prosternal furrow and sternopleura without pile; posterior surface of middle coxae with some pile. Pleura and coxae white-grey tomentose.

Legs. Fore femora with 1 or 2 pd macrosetae, 1 or 2 av, and 1 pv; middle femora with 1 av and 1 or 2 pv; hind femora with 1-3 av and 1 pv. Legs blackish. Pile of hind femora whitish, moderately long, semi-appressed.

Wings grey-brown hyaline; veins brown-black; stigma pale brown. Halteres blackish.

Abdomen white-grey tomentose, with moderately long whitish pile.

Terminalia. Epandrium (Fig. 159) about as wide as long; pile evenly distributed; cerci about half as long as epandrium. Gonocoxites (Fig. 160) extended posteriorly, fused with each other for a long distance; hypandrial element greatly reduced. Inner style with a large dorsal lobe. Aedeagus (Fig. 161) with phallic part strongly undulating.

Female. As for male except as follows. Eyes separated at level of anterior ocellus by 4.2X its width. Abdominal tergites indistinctly banded, with darker tomentum on anterior parts than on posterior parts.

Terminalia. S8 in face view (Fig. 284) with posterior part and a strip along midline weakly sclerotised, with inner margins of additional sclerotisation showing up as 2 dark lines, and with setae long, thin, anteriorly directed, in profile (Fig. 285) with a slight incurvation behind middle. Third A1 seta about 7X as long as wide, blunt-tipped; 8 A1 setae per side. Longest A2 seta about as long as 3rd A1 seta; 7 A2 setae per side.

Dimensions. Body length 9–11 mm, wing 7.2–8.9 mm.

Type data. Holotype: male, TO, Tongario [sic] National Park, 11 February 1973, H. Hayakawa (ZMKD).

Paratypes: 4 males, 3 females, same data as holotype (NZAC, ZMKD); 1 female, TO, Kuratau, 17 February 1973, H. Hayakawa (ZMKD); 3 males, 2 females, TO, Mt Tongariro, 1200 m, January 1970, K. Spitzer (ZMKD); 1 male, 2 females, TO, Mt Tongariro N.P., Mangatepopo, Chateau Track, 11 February 1973, R.A. Harrison & S.A. Timms (LCNZ); 1 male, 1 female, TO, Mt Tongariro N.P., The Chateau grounds, 11 February 1973, K.M. Mason (LCNZ); 1 male, 2 females, TO, Mt Tongariro N.P., Mangatepopo Hut, ex volcanic scoria, 11 February 1973, R.M. Emberson & K.M. Mason (LCNZ); 1 male, WN, Wairongomai R., on stones, 24 February 1928, A. Castle (NMNZ); 1 female, WD, Waiho, 25 January 1922, A. Tonnoir (NZAC).

Material examined. Type series only.

— / TO, WN / WD / —

Remarks. The male of *A. ostentatus* is easily recognised by the very distinctive phallic part of the aedeagus, which is observable without dissection. Both sexes have remarkably long facial setae, from a few to about a dozen.

Six New Zealand species of *Anabarhynchus* — *arenarius*, *fenwicki*, *fluvialis*, *harrisi*, *monticola*, and *ostentatus* — have the male frons narrower than the anterior ocellus, but they probably do not constitute a natural group.

Anabarhynchus postocularis new species

Figures 168–170, 282, 283

Male. Head. Eyes separated in front of anterior ocellus by 4–5x its width. Frons distinctly raised from just below anterior ocellus; tomentum either greyish with a brownish tinge, and with traces of a dark brownish transverse stripe below mid frons, or entire upper frons extensively dark brownish; areas laterad of antennal bases dark brown tomentose; pile black; setae as long as scape or longer. Face bare. Scape, pedicel, and base of 1st flagellar segment brownish, with thin tomentum; remainder of flagellum black. Terminal flagellar segments together about one-third as long as 1st segment. Occiput with about 30 black macrosetae on either side; 4 or 5 upper macrosetae elongate, anteriorly directed. Pile on lower occiput and genae mostly whitish; anterior part of genae with some black setae. Palpi yellowish.

Thorax. Macrosetae: np 3 or 4, sa 2, pa 1, dc 2 or 3, sc 2; all setae black. Disc of mesonotum greyish tomentose, with

a pattern of 7 dark brown stripes or series of spots variable in extent. Lateral mesonotal areas — i.e., humeri, notopleura, and postalar calli — with yellow-brown ground colour similar to that of pleura and coxae, and with a thin whitish tomentum. Mesonotal pile rather long, composed of whitish and blackish setae. Prosternal furrow, sternopleura, and posterior surface of middle coxae without pile. Scutellum grey with brownish disc and white pile.

Legs. Fore femora with 1–3 av macrosetae; middle femora with 1 or 2 pv; hind femora with 1 or 2 av and 1 pv. Femora neither yellow-brown nor grey-black, but somewhat intermediate; ventral surface usually clearly yellow-brown, and dorsal surface more blackened apicad. Dorsal surface of hind femora with pile composed of whitish semi-scaly setae and short, stiff, black setae; ventral surface with moderately long whitish pile; some setae as long as half femoral width. Tibiae dirty yellow-brown, blackened towards apices.

Wings greyish hyaline with more or less distinct brownish streaks along veins; veins very dark except for yellow-brown Sc; stigma brown-black. Halteres blackish.

Abdomen. T2–6 on disc with well marked, shiny black anterior bands reaching posterior margin in midline; lateral and posterolateral areas yellow-brown to red-brown, thinly whitish tomentose, resulting in a nearly pinkish colour. Pile black on dark bands, whitish on pink areas. Venter yellowish to reddish brown; pile whitish.

Terminalia yellow-brown with a pile of black and pale setae. Epandrium (Fig. 168) narrowing posteriorly, 1.6x as wide as long; cerci oval. Gonocoxites (Fig. 169) posteriorly broadly rounded and fused for some distance; a narrowly triangular hypandrial element entering anterior part of synsclerite. Outer style slender, simply rounded at apex. Aedeagus (Fig. 170) with phallic part remarkably long, slender, straight, perpendicular to aedeagus.

Female. As for male except as follows. Eyes separated by 5.2–6.0x width of anterior ocellus. Frons more intensely brownish tomentose, and postocular setae shorter. Pile on lateral parts of T4 and over all following tergites black.

Terminalia. S8 in face view (Fig. 282) with a few posteriorly directed setae in addition to weak pile on posterior lobe, in profile (Fig. 283) with a slight incurvation. Third A1 seta about 4x as long as wide, blunt-tipped to slightly spatulate; 6 A1 setae per side. Longest A2 seta about 3x as long as 3rd A1 seta; 7 or 8 A2 setae per side.

Dimensions. Body length 6.7–7.0 mm, wing about 7 mm.

Type data. Holotype: male, CO, Clutha River bed 4 km E of Clyde, 6 December 1977, E.I. Schlinger (CISB).

Paratypes: 1 male, 1 female, MB, Tarndale Homestead,

18 November 1972, R.A. Harrison (LCNZ, ZMKD); 1 male, MC, Bankside Sci. Res., swept *Danthonia* grassland, 25 October 1978, J.W. Early (LCNZ); 1 male, CO, Kawarau Gorge, Roaring Meg, 22 November 1974, beaten at night, J.C. Watt (NZAC); 3 females, same data as holotype.

Material examined. Type series only.

— / MB, MC, CO / —

Remarks. *A. postocularis* and *A. brevicornis* are sister-species. Synapomorphic characters are the shortened first flagellar segment and the yellow-brown coloration of the pleura, coxae, and lateral mesonotal areas. A sister-group to the group formed by these two species can hardly be envisaged.

Anabarthynchus robustus new species

Figures 165–167, 286, 287

Male. Head. Eyes separated in front of anterior ocellus by 3–4X its width. Frons uniformly grey tomentose, protruding over entire length; pile black, stiff, erect; setae longer than scape. Face bare. Scape greyish; flagellum blackish; terminal flagellar segments together slightly less than half as long as 1st segment. Occiput with 60–70 strong black macrosetae on either side. Pile of lower occiput and genae stiff, blackish along eye margin, softer and whitish towards middle of head. Palpi grey-black.

Thorax. Macrosetae: np 4 or 5, sa 2, pa 1, dc 2–4, sc 2 or 3; all setae strong, black. Mesonotum dark greyish tomentose, usually with indistinct traces of dark brown stripes; pile rather long, black. Scutellum greyish; pile black. Prosternal furrow with some yellowish pile; sternopleura bare; hind surface of middle coxae usually bare, frequently also with a few pale setae. Pleura and coxae dark greyish.

Legs. Fore femora with 1 av macroseta; middle femora without macrosetae; hind femora with 1 or 2 av and 1 pv. Legs blackish; femora with thin greyish tomentum. Pile of ventral surface of hind femora short, black, dorsally composed of mixed pale and black setae.

Wings dark grey-brown hyaline; veins and stigma brown-black. Halteres brown-black.

Abdomen shiny brown-black on disc of tergites; narrow hind marginal strips and posterolateral corners greyish tomentose; pile black on black areas, whitish on tomentose areas. Sternites grey-black; pile whitish.

Terminalia grey-black with blackish pile. Epandrium (Fig. 165) slightly wider than long; cerci rather short. Gonocoxites (Fig. 166) with a zone of fusion for some distance, and with marked zones of fusion with hypandrium. Outer style with a pronounced tooth some distance

from apex. Aedeagus (Fig. 167) with phallic part a very long, evenly thick tube; apex rapidly narrowing.

Female. As for male except as follows. Eyes separated by about 5X width of anterior ocellus. Frontal pile shorter. Fore femora often with 2 av macrosetae.

Terminalia. S8 in face view (Fig. 286) with a depressed area stretching from margin to margin, and laterally with a row of posteromedially directed setae, in profile (Fig. 287) with a very deep incurvation of posterior part; pile of posterior lobe long, dense. Third A1 seta about 5X as long as wide, blunt-tipped; 7 A1 setae per side. Longest A2 seta about twice as long as 3rd A1 seta; 7 or 8 A2 setae per side.

Dimensions. Body length 12–14 mm, wing 9.8–10.6 mm.

Type data. Holotype: male, NC–WD, Arthurs Pass, 8–11 January 1957, E.S. Gourlay (NZAC).

Paratypes: 1 female, RI, Ohakune, 10 January 1920 (BMNH); 1 female, RI, Ohakune, March 1922, T.H. (USNM); 1 female, BR, Owen River, 20 November 1957, M.J. Esson (NZAC); 1 female, same data as holotype; 1 male, 1 female, NC, Arthurs Pass, 24 and 26 January 1923, ? coll. (AMNZ); 1 female, NC, Arthurs Pass, 25 December 1922, [J.G.] Myers (BMNH); 1 male, WD, Otira, 10 January 1920, ? coll. (CUIC); 1 female, WD, Okarito Beach, 12 February 1976, R.H. Blank (LCNZ); 1 female, WD, Waiho Gorge, 18 February 1924, A. Castle (NMNZ); 1 male, 1 female, WD, Karangarua R., 12 December 1960, P. Kettle & J.I. Townsend (NZAC); 1 male, 1 female, WD, L. Paringa, 6–10 December 1960, J.I. Townsend & P.R. Kettle (NZAC); 1 female, WD, Hollyford Vly, Rainbow Ck, 12 February 1980, J.W. Early (LCNZ); 1 female, FD, Milford Sd, 30 January 1946, R. Forster (NMNZ); 1 male, FD, Milford Sd, Harrison Cove, 16 January 1952, Galathea Exp'n (ZMKD); 4 females, FD, Homer Tunnel, 26 January 1946, R. Forster (NMNZ); 3 males, 3 females, FD, Homer cirque and riverbed, 30 January 1990, R.B. Morris & J.S. Dugdale (NZAC); 1 female, FD, Eglinton Vly, 20 January 1959, E.S. Gourlay (NZAC); 2 males, 1 female, FD, Deep Cove, 3 February 1983, J.W. Early (LCNZ); 1 female, FD, Mica Burn, January 1970, J.S. Dugdale (NZAC); 1 male, FD, Manapouri, Turret Ra., Mt Grey, 3300–4000' [1000–1200 m], 14 January 1970, J.S. Dugdale (NZAC); 1 male, 2 females, FD, Grebe Vly, S arm of L. Manapouri, 4 February 1982, J.W. Early (LCNZ); 1 female, FD, Borland Saddle, 1005 m, 2 February 1982, C.A. Muir (LCNZ); 1 female, OL, Makarora, December 1924, Fenwick Coll. (NMNZ); 1 female, OL, Hollyford R. at end of road, 5 February 1980, J.W. Early (LCNZ); 1 female, OL, L. Wakatipu, "1906.154", G.V. Hudson (BMNH); 1 female, CO, Mt Ida, 19 February 1922 (AMNZ).

Material examined. Type series only.
— / RI / BR, NC, WD, FD, OL, CO / —

Remarks. See Remarks under *A. acuminatus*.

Anabarhynchus ruficoxa new species

Figures 171–173, 288, 289

Male. Head. Eyes separated in front of anterior ocellus by about 3.4x its width. Frons protruding over entire length, grey-brown to nearly all cinnamon brown tomentose; pile black, erect; setae as long as scape or shorter. Face bare. Scape, pedicel, and basal part of 1st flagellar segment yellow-brown, more or less white-grey tomentose; remainder of flagellum blackish. Terminal flagellar segments together about half as long as 1st segment. Occiput with 25–30 black macrosetae on either side. Pile of lower occiput and genae pale brownish. Palpi yellow-brown.

Thorax. Macrosetae: np 4 or 5, sa 2, pa 1, dc 1 or 2, sc 2; all setae black, strong. Mesonotum and scutellum dark grey-brown tomentose, paler grey towards margins, the former with 3 indistinctly marked brown-black stripes; pile rather short, black. Prosternal furrow, sternopleura, and posterior surface of middle coxae without pile. Pleura grey-brown tomentose. Coxae yellow-brown with slight tomentum (i.e., not as bright as femora).

Legs. Fore femora without macrosetae or with 1 or 2 av; middle femora without macrosetae; hind femora with 1 or 2 av and 1 or 2 pv. Femora and tibiae yellow-brown, bright or with some infuscation. Ventral surface of hind femora with long, erect, whitish pile, a few of the setae sometimes as long as femoral width; dorsal surface with a mixture of short black and white setae.

Wings grey-brown hyaline with slightly darker streaks along brownish veins; stigma brown-black. Halteres pale yellowish.

Abdomen. Tergites in strict dorsal view practically all black; narrow hind margins and narrow posterolateral corners yellow-brown to red-brown, with slight silvery-white tomentum; lateral areas of tergites and entire sternites similarly coloured. Pile very sparse, short, black on dorsum, white on remainder.

Terminalia grey-brown. Epandrium (Fig. 171) about 1.4x as wide as long; cerci relatively large, practically free of pile. Gonocoxites (Fig. 172) without distinct zones of mutual fusion but with weak zones of fusion with hypandrial element; outer style with a very sharp apex. Aedeagus (Fig. 173) of a generalised type.

Female. As for male except as follows. Eyes separated by about 3.7x width of anterior ocellus. Frontal pile shorter.

Abdomen extensively yellow-brown towards apex.

Terminalia. S8 in face view (Fig. 288) with short pile restricted in distribution, in profile (Fig. 289) with a moderate incurvation of posterior half. Third A1 seta about 6x as long as wide, blunt-tipped; 7 or 8 A1 setae per side. Longest A2 seta about 1.8x as long as 3rd A1 seta; 7 or 8 setae per side.

Dimensions. Body length 9–10 mm, wing 7.9–8.2 mm.

Type data. Holotype: male, SI, Codfish I., Sealers Bay, 8 December 1966, J.I. Townsend (NZAC).

Paratypes: 1 male, WN, Red Rocks, coastline 0–200 m, off kelp, 5 December 1980, N. Elvidge & G.W. Hornabrook (NMNZ); 1 male, 1 female, WN, Turakirao Head, 17 February 1981, N. Elvidge & C.W. Hornabrook (NMNZ); 3 females, BR, L. Rotoiti, December 1980, F. Dodge (NZAC); 3 females, DN, Dunedin, Leith Saddle, broadleaf forest, 28 November 1975 and 25 December 1989, A.C. Harris (OMNZ); 1 male, DN, Peninsula Co., 14 November 1916, ? coll. (AMNZ); 10 females, SI, Lee Bay, 26 December 1975 to 23 January 1976, A.C. Harris (OMNZ); 1 female, same data as holotype.

Material examined. Type series only.

— / WN / BR, DN / SI / —

Anabarhynchus rufobasalis new species

Figures 174–176, 292, 293

Male. Head. Eyes separated in front of anterior ocellus by 3x its width. Frons hardly protruding; pile black; setae slightly shorter than scape. (Head discoloured; flagellum missing.) Face bare. Occiput with over 60 black macrosetae on either side. Pile of lower occiput and genae whitish. Palpi brownish.

Thorax. Macrosetae: np 6 or 7, sa 1, pa 1, dc 2, sc 2; all setae black, strong. (Thorax discoloured.) Mesonotal pile short, black. Scutellum with rather short pile of mixed black and yellow-brown setae. Prosternal furrow, sternopleura, and posterior surface of middle coxae without pile. Pleura and coxae greyish.

Legs. Fore and middle femora without macrosetae; hind femora with 1 av and 1 pv. Fore femora blackish, indistinctly brownish basally; middle femora red-brown over slightly more than proximal half, blackish over remainder; hind femora red-brown over proximal three-quarters, blackish over remainder. Pile on ventral surface of hind femora sparse, white-yellow, with setae about one-quarter as long as femoral width, on dorsal surface composed of semiscale white-yellow setae and normal black setae, the for-

as femoral width, on dorsal surface composed of semi-scaly white-yellow setae and normal black setae, the former restricted to the red-brown parts. Tibiae red-brown to yellow-brown, with distal half blackish in fore tibiae and distal fourth blackish in middle and hind tibiae.

Wings grey-brown hyaline, most intensely coloured in streaks along veins; stigma and veins brown-black. Halteres brownish black.

Abdomen (discoloured) probably grey-brown tomentose; pile blackish, appressed on disc, whitish and more erect on lateral parts.

Terminalia blackish; pile black. Epandrium (Fig. 174) wider than long, with a crescent-shaped demclanised area; cerci very large, about as long as epandrium. Gonocoxites (Fig. 175) with distinct zones of fusion with each other and with hypandrium. Outer style with apex obliquely truncate. Aedeagus (Fig. 176) with phallic part a very wide tube.

Female. As for male except as follows. Frons dark brown tomentose above, gradually more golden grey-brown below. Occiput with fewer macrosetae. Thoracic macrosetae: only 4 np. Mesonotum dark grey-brown tomentose, with 2 paler grey-brown bands and 5 dark brownish stripes. Scutellum greyish; disc brown-black. Fore femora with 1 av macroseta; hind femora with 2 av and 1 pv. Femora more yellow-brown, and blackish apical areas more restricted. Tibiae less distinctly darkened apically. Tergites blackish on disc, greyish on a nearly parallel-sided lateral strip.

Terminalia. S8 in face view (Fig. 292) wide relative to its length and with an oval, depressed, demclanised area, in profile (Fig. 293) with a marked incurvation at middle; pile rather weak. Third A1 seta about 4.4x as long as wide, tapering from base to apex, thus rather sharp-pointed; 9 A1 setae per side. Longest A2 seta about 2.5x as long as 3rd A1 seta; 8 or 9 A2 setae per side.

Dimensions. Body length about 12 mm, wing 10.0–10.4 mm.

Type data. Holotype: male, TO, Te Whaiti, 4 February 1934, J.S. Armstrong (NZAC).

Paratypes: 1 female, TK, Mt Egmont, summit 8000' [2400 m], in snowdrift, 17 January 1955, G.W. Ramsay (NZAC); 1 female, TK, Egmont, Kapuni Vly, 1100–1400 m, 19 February 1977, J.S. Dugdale (NZAC).

Material examined. Type series only.

— / TO, TK / —

Anabarhynchus schlinger new species

Figures 177–179, 296, 297

Male. Head. Eyes separated in front of anterior ocellus by 4.8x its width. Frons pale white-grey tomentose, slightly protruding over entire length; pile black; setae about as long as scape. Face bare. Scape greyish; flagellum blackish; terminal flagellar segments together slightly less than half as long as 1st segment. Occiput with about 50 relatively short, weak macrosetae on either side. Pile of lower occiput and genae yellow-white. Palpi brown-yellow.

Thorax. Macrosetae: np 5, sa 2, pa 1, dc 2 or 3, sc 2; all setae black, relatively weak. Mesonotum and scutellum greyish, with traces of 3 brown stripes on disc; pile rather short, black; whitish setae intermixed on scutellum. Prosternal furrow, sternopleura, and posterior surface of middle coxae without pile. Pleura and coxae greyish; anterior spiracles and their immediate surroundings orange.

Legs. Fore femora with 1 av macroseta; middle femora without macrosetae; hind femora with 1 or 2 av, 1 pv, and an additional macroseta on anterior surface. Femora greyish black; hind femora very indistinctly brownish translucent on ventral surface (cf. female). Pile of hind femora nearly exclusively whitish; some ventral hair-like setae about one-third as long as femoral width; semi-scaly, hair-like setae present on dorsal surface. Tibiae piceous brown.

Wings grey hyaline; veins and stigma brown-black. Halteres partly yellowish, partly brown-black.

Abdomen. Tergites entirely greyish tomentose, on disc with appressed black pile, laterally with erect whitish pile. Sternites greyish with whitish pile.

Terminalia brown-black; gonocoxites with mainly pale setae. Epandrium (Fig. 177) wider than long. Gonocoxites (Fig. 178) bifurcate posteriorly, briefly fused via a hyaline area; hypandrium band-shaped, rather discrete; anterior apodeme unusually long. Aedeagus (Fig. 179) with phallic part wide throughout, abruptly narrowing into sharp apex.

Female. As for male except as follows. Eyes separated by about 5.5x width of anterior ocellus. Frontal tomentum darker, in part with a brownish tinge. Thoracic macrosetae: 2+2 dc. Middle and especially hind femora paler, with ventral surface of hind femora markedly red-yellow translucent in one female, indistinctly so in the other, and with a similar tendency on middle femora. T5 and following tergites with coarse black pilosity.

Terminalia. S8 in face view (Fig. 296) with a pair of very deep impressions, in profile (Fig. 297) with a nose-shaped projection at middle; pile mainly anteriorly directed. Third A1 seta about 6x as long as wide, blunt-tipped; 8 or 9 A1 setae per side. Longest A2 seta about 1.7x as long as 3rd A1 seta; 8 A2 setae per side.

Dimensions. Body length 12–13 mm, wing about 10.5 mm.

Type data. Holotype: male, NC, Nape Nape Scenic Reserve nr Hurunui River mouth shore area, 17 November 1977, E.J. Schlinger (CISB).

Paratypes: 2 females, same data as holotype (CISB, NZAC).

Material examined. Type specimens only.

— / NC / —

Anabarhynchus similis new species

Figures 180–182, 300, 301

Male. Head. Eyes separated in front of anterior ocellus by 2.1x its width. Frons grey-brown tomentose, protruding in lower half; pile black, erect; setae longer than scape. Face bare. Scape grey-black; flagellum blackish; terminal flagellar segments together 0.6x as long as 1st segment. Occiput with numerous hair-like macrosetae becoming gradually stronger towards vertex. Pile on lower occiput and genae whitish behind, blackish along eye margin of occiput and genae. Palpi grey-black.

Thorax. Macrosetae: np 4, sa 2, pa 1, dc 0, sc 2; all setae black, relatively weak. Mesonotum uniformly grey-brown tomentose; pile moderately long, black, erect. Scutellum grey-black tomentose; pile long, black; some setae nearly as long as sc macrosetae but weaker. Prosternal furrow, sternopleura, and posterior surface of middle coxae without pile. Pleura and coxae uniformly dark greyish tomentose.

Legs. Fore femora without macrosetae; middle femora with 2 av; hind femora with 5 or 6 irregularly arranged av. Femora black, slightly dulled by a thin greyish tomentum. Pile on ventral surface of hind femora long, erect, black, with some setae as long as femoral width, on dorsal surface long, erect, composed mainly of whitish hair-like setae. Tibiae blackish.

Wings grey hyaline; veins dark brownish, stigma brownish. Halteres blackish brown.

Abdomen. T2–5 dull to subshiny brown-black on anterior parts, greyish to nearly bluish grey tomentose on lateral and posterior parts. Sternites greyish. Abdominal pile rather short, sparse, dark on brown-black tergal areas, whitish elsewhere.

Terminalia brown-black with blackish pile. Epandrium (Fig. 180) about 1.3x as wide as long; cerci small, roundish. Gonocoxites (Fig. 181) with a posteromedially directed extension, fused via a hyaline area for a short distance

posterior to triangular hypandrium, which bears a few hair-like setae. Outer style with minute setae apically. Aedeagus (Fig. 182) of a generalised type.

Female. As for male except as follows. Eyes separated by 4.5–4.6x width of anterior ocellus. Frons protruding over entire length. Middle femora with up to 4 av macrosetae; hind femora sometimes with fewer av. Abdominal pattern less marked, as tomentum of lateral and posterior parts of T2–5 darker grey.

Terminalia. S8 in face view (Fig. 300) wider posteriorly than anteriorly (cf. *atripes*), in profile (Fig. 301) with only an indication of an incurvation near middle. Third A1 seta about 5x as long as wide, blunt-tipped; 7 A1 setae per side. Longest A2 seta about twice as long as 3rd A1 seta; 7 A2 setae per side.

Dimensions. Body length 11–13 mm, wing 9.0–9.4 mm.

Type data. Holotype: male, NC–WD, Arthurs Pass, 3000' [900 m], 7–11 February 1920, G.V. Hudson (BMNH).

Paratypes: 1 female, NC–WD, Arthurs Pass, 3000' [900 m], 22 January 1923, G.V. Hudson (BMNH); 2 females, SC, Mt Peel, 26 and 28 February 1921, A. Philpott (NZAC).

Material examined. Type specimens only.

— / NC–WD, SC / —

Remarks. *A. similis* is clearly the sister-species of *A. atripes*, described from the western Olivine Range; for further details, see Remarks under *atripes*.

Anabarhynchus simplex new species

Figures 183–185

Male. Head. Eyes separated in front of anterior ocellus by 2.8x its width. Frons uniformly grey-brown tomentose, not protruding in lateral view; pile black, very long; some setae twice as long as scape. Face bare. Scape grey-black; flagellum blackish, brownish at base, with 1st segment slightly longer than wide; terminal flagellar segments together about half as long as 1st segment. Occiput with about 25 rather long, thin, curved, black macrosetae on either side. Pile of lower occiput and genae long, whitish. Palpi brownish.

Thorax. Macrosetae: np 3, sa 1, pa 1, dc 1, sc 2; all setae black, remarkably slender; dc and sc setae especially not clearly distinguishable from long black pilosity on posterior part of mesonotum and on scutellum. Mesonotum with an irregular pattern of dull brown and grey. Scutellum

brownish on disc, greyish along posterior margin. Prosternal furrow without pile; lower part of sternopleura and posterior surface of middle coxae with a little whitish pile. Pleura and coxae dull brownish with a thin whitish tomentum; lower part of sternopleura and pteropleura greyish.

Legs. Fore femora with 1 indistinct av macroseta; middle femora without macrosetae; hind femora with 1 or 2 av and 1 pv. Fore and middle femora blackish; hind femora brownish. Pile of hind femora composed of uniform, simple, semi-erect to erect blackish setae, those on ventral surface as long as half femoral width. Tibiae brownish, blackened at apices and in spots around macrosetae.

Wings very dark greyish-brown in distal half, especially in streaks along veins, in proximal half slightly more hyaline, mainly in basal part of cell r_1 proximal to stigma; veins and stigma brown-black. Halteres blackish.

Abdomen. Tergites in dorsal view polished black on disc, in lateral view with extreme lateral areas yellow-brown translucent, partly whitish tomentose; pile short and black on disc, longer and whitish on lateral areas. Sternites dull brownish.

Terminalia brownish to brown-black with black pile. Epandrium (Fig. 183) wider than long; pile very restricted; cerci oval. Gonocoxites (Fig. 184) anteriorly solidly fused with hypandrial element; a distinct semi-hyaline area posterior to hypandrium. Outer and inner styles simple. Aedeagus (Fig. 185) with phallic part long, slender, of nearly even width, with apex only slightly upcurved.

Female. Unknown.

Dimensions. Body length about 5 mm, wing 3.7 mm.

Type data. Holotype: male, MC, Port Hills, October 1919, Lindsay Coll. (CMNZ).

Material examined. Holotype only.

— / MC / —

Remarks. *A. simplex* is by far the smallest *Anabarhynchus* in New Zealand.

***Anabarhynchus spiniger* new species**

Figures 59, 186–188, 294, 295

Male. Head. Eyes separated in front of anterior ocellus by about 1.8x its width. Frons grey to grey-brown tomentose, narrowly protruding in lower part; pile black, erect; setae shorter than scape. Face with a few pale setae laterally. Scape greyish; flagellum black; terminal flagellar seg-

ments together about half as long as 1st segment. Occiput with 30–45 moderately strong black macrosetae on either side. Pile of lower occiput and genae whitish. Palpi greyish.

Thorax. Macrosetae: np 3 or 4, sa 2, pa 1, dc 2, sc 2; all setae black, strong. Mesonotum greyish, with more or less distinct traces of dark brown stripes or spots; pile composed of erect black setae and more appressed pale setae. Scutellum grey to grey-brown; pile long, pale yellowish. Prosternal furrow and sternopleura without pile; posterior surface of middle coxae with some pile. Pleura and coxae uniformly greyish tomentose.

Legs. Fore femora with 3–5 pd macrosetae and 1–4 av; middle femora usually with 1 av and 1 pv, both weak; hind femora with 3–5 av and 1 or 2 pv. Legs uniformly blackish. Pile of hind femora yellowish, dense, rather long, semi-appressed to appressed, not scaly.

Wings uniformly grey-brown hyaline; veins and stigma dark brown. Halteres blackish.

Abdomen uniformly silvery greyish tomentose; pile whitish.

Terminalia blackish with yellowish pile. Epandrium (Fig. 186) slightly narrower than long; cerci slender, about half as long as epandrium. Gonocoxites (Fig. 59, 187) with a sharp posteroventral process and with a marked zone of fusion for a long distance; hypandrial element minute. Outer and inner styles heavy relative to size of gonocoxite. Aedeagus (Fig. 188) with phallic part dorsally 'hooded'.

Female. As for male except as follows. Eyes separated by 5.2–5.5x width of anterior ocellus. Middle femora with 2 av and 2 pv macrosetae; hind femora with up to 6 av distributed over nearly entire length. T2–4 with blackish anterior bands.

Terminalia. S8 in face view (Fig. 294) ovoid with a pair of rectangular demelanised areas, in profile (Fig. 295) evenly convex; pile restricted to posterior lobe and a strip between demelanised areas. Third A1 seta about 5x as long as wide, blunt-tipped; 7 A1 setae per side. Longest A2 seta about 1.4x as long as 3rd A1 seta; 7 or 8 A2 setae per side.

Dimensions. Body length about 9 mm, wing 6.8–7.0 mm.

Type data. Holotype: male, CO, Tarras, 1000' [300 m], 16–22 January 1954, E.S. Gourlay (NZAC).

Paratypes: 1 male, 3 females, same data as holotype (NZAC); 1 male, KA, Oaro, 14 November 1972, H. Haya-kawa (ZMKD).

Material examined. Type specimens only.

— / KA, CO / —

Remarks. See Remarks under *A. brunneri*.

Anabarhynchus spitzeri new species

Figures 189–191

Male. Head. Eyes separated in front of anterior ocellus by 2.2–2.4x its width. Frons white-grey tomentose, narrowly protruding in lower part; pile black, weak; setae shorter than scape. Face bare. Scape greyish; flagellum blackish; terminal flagellar segments together about half as long as 1st segment. Occipital macrosetae black, rather weak and short, about 45 on either side. Pile of lower occiput and genae whitish. Palpi grey.

Thorax. Macrosetae: np 2–4, sa 2, pa 1, dc 0 or 1, sc 2; all setae black. Mesonotum white-grey tomentose, unpatterned; pile composed of black and white setae. Scutellum greyish; pile whitish. Prosternal furrow and sternopleura without pile; posterior surface of middle coxae with some pile. Pleura and coxae white-grey tomentose.

Legs. Fore and middle femora without macrosetae, or fore femora with 1 weak ad and 1 av; hind femora with 1 or 2 weak av and 1 pv. Legs uniformly blackish. Pile of hind femora sparse, short, erect to semi-erect, composed of black and white setae.

Wings grey-brown hyaline; veins and stigma brown-black. Halteres blackish.

Abdomen. T2–5 with marked blackish anterior bands, on T2 occupying three-quarters of tergal length, on T3–5 becoming gradually narrower; posterolateral areas of T2–5 and all of T6 and T7 silvery-white tomentose. Pile of dark areas black, appressed, of white areas white, erect.

Terminalia grey-black with mainly pale pile. Epandrium (Fig. 189) about twice as wide as long, deeply incised anteriorly; posterolateral corners with 'rims'; cerci slender, about as long as epandrium. Gonocoxites (Fig. 190) fused along midline for some distance, and with posterior margin straight; hypandrium well developed. Outer style very slender; inner style remarkably stout in proximal part. Aedeagus (Fig. 191) with phallic part nearly straight.

Female. Unknown.

Dimensions. Body length about 8 mm, wing about 6 mm.

Type data. Holotype: male, OL, Haast Pass, 1500 m, February 1970, K. Spitzer (ZMKD).

Paratypes, 1 male, OL, Makarora, 1000–2000 ft [300–600 m], 11 December 1924, Fenwick Coll. (NMNZ).

Material examined. Type specimens only.

— / OL / —

Remarks. *A. spitzeri* is externally very similar to *A. fenwicki* and occurs sympatrically with it at Makarora.

Anabarhynchus triangularis new species

Figures 192–194, 298, 299

Male. Head. Eyes separated in front of anterior ocellus by 2.5–2.7x its width. Frons grey-brown tomentose, protruding over entire length; pile black; setae as long as scape. Face bare. Scape grey-black; flagellum blackish; terminal flagellar segments together about half as long as 1st segment. Occiput with about 40 relatively short black macrosetae on either side. Pile of lower occiput and genae whitish. Palpi yellowish.

Thorax. Macrosetae: np 4, sa 2, pa 1, dc 2, sc 2; all setae black. Mesonotum grey-brown tomentose, with indistinct traces of darker brownish stripes; pile short, mainly blackish; whitish, hair-like setae intermixed anteriorly, laterally, and posteriorly. Scutellum grey-brown; pile whitish. Prosternal furrow, sternopleura, and posterior surface of middle coxae without pile. Pleura and coxae white-grey tomentose.

Legs. Fore and middle femora without macrosetae; hind femora with 1 or 2 av and 1 pv. Femora yellow-brown; fore and middle femora slightly darkened dorsally at extreme apex; hind femora more extensively darkened. Pile of hind femora nearly all whitish, with short black setae intermixed dorsally; whitish hair-like setae on dorsal surface semiscaly, those on ventral surface as long as one-quarter of femoral width. Tibiae yellow-brown.

Wings uniformly grey-brown hyaline; veins brownish; stigma indistinctly darker than wings. Halteres dirty yellowish.

Abdomen. Tergites grey to grey-black, with lateral margins more or less red-yellow translucent and middle area with a dense cover of appressed black setae, thus appearing darker. Sternites red-yellow with a more or less thick cover of grey tomentum. Pile of remainder of abdomen whitish.

Terminalia red-yellow; epandrium with black setae; gonocoxites with yellowish setae. Epandrium and cerci (Fig. 192) together triangular; epandrium slightly wider than long; cerci about half as long as epandrium. Gonocoxites (Fig. 193) not directly fused ventrally, but connected via a hyaline area; hypandrium forming a rather discrete sclerite. Outer style with apex sharp, curved. Aedeagus (Fig. 194) with phallic part short, wide, strongly S-curved.

Female. As for male except as follows. Eyes separated by about 3.7x width of anterior ocellus. Occipital macrosetae apparently stronger. Mesonotal dark stripes sometimes slightly more distinct. Last tergites and sternites with more stiff black pilosity.

Terminalia. S8 in face view (Fig. 298) oblong oval, with

a very well marked posterior lobe and an arrangement of a few strong setae, in profile (Fig. 299) with a very slight concavity. Third A1 seta about 4X as long as wide, blunt-tipped; 6 or 7 A1 setae per side. Longest A2 seta about 2.5X as long as 3rd A1 seta; 7 or 8 A2 setae per side.

Dimensions. Body length 9.0–9.4 mm, wing 8.1–9.2 mm.

Type data. Holotype: male, CO, Kawarau Gorge, Roaring Meg, beaten from shrubs at night, 25 November 1974, J.C. Watt (NZAC).

Paratypes: 1 male, 2 females, same data as holotype (NZAC); 1 male, CO, Cromwell Gorge, Roaring Meg, 12 December 1984, J.S. Dugdale (NZAC).

Material examined. Type specimens only.

— / CO / —

Anabarhynchus tricoloratus new species

Figures 195–197, 290, 291

Male. Head. Eyes separated in front of anterior ocellus by about twice its width. Frons grey-brown tomentose above, greyish tomentose below, not protruding; pile black and/or whitish; setae about as long as scape or shorter. Face bare. Scape greyish; flagellum blackish; terminal flagellar segments together about half as long as 1st segment. Occiput with 35–40 rather short, black and/or whitish macrosetae on either side. Pile of lower occiput and genae whitish. Palpi yellowish.

Thorax. Macrosetae: np 3 or 4, sa 2, pa 1, dc 1 or 2, sc 2; all setae black. Pattern of mesonotum tricoloured: 3 broad brown-yellow bands separated by white-grey tomentum; lateral bands interrupted at notopleural furrow, with dark brown tomentum laterally and medially; middle band with a dark brown median stripe; pile black, moderately long. Scutellum brown-black, greyish along margin; pile whitish. Prosternal furrow and sternopleura without pile; posterior surface of middle coxae with some pile. Pleura and coxae white-grey.

Legs. Fore femora with 1 pd macroseta and 1 av; middle femora with 1 or 2 pv; hind femora with 1 av and 1 pv; femoral macrosetae black or demelanised. Femora and tibiae brownish. Pile of hind femora short, appressed, composed of whitish and/or blackish setae.

Wings whitish, with dark central areas in most cells; veins coarse, blackish; R_1 with a few small setae on section passing through blackish stigma. Halteres yellowish.

Abdomen greyish, unpatterned; pile white-yellow.

Terminalia grey-yellow; pile whitish. Epandrium (Fig.

195) about twice as wide as long; cerci relatively large. Gonocoxites (Fig. 196) with a rather long zone of fusion with each other and with hypandrial element. Styles and aedeagus (Fig. 197) close to ground-plan for *nebulosus*-group.

Female. As for male except eyes separated by about 5X width of anterior ocellus.

Terminalia. S8 in face view (Fig. 290) with setae arranged in quite a different way from other *nebulosus*-group species (cf. Fig. 274 and 302), in profile (Fig. 291) rather irregular. Third A1 seta 8–9X as long as wide; 8 A1 setae per side. Longest A2 seta slightly longer than 3rd A1 seta; 6–8 A2 setae per side, all weak and hair-like.

Dimensions. Body length 7–8 mm, wing 6.1–7.2 mm.

Type data. Holotype: male, AK, Whatipu Beach, 24 November 1968, B.M. May (NZAC).

Paratypes: 1 female, ND, Waipoua, 13 October 1967, J.S. Dugdale (NZAC); 2 males, 1 female, ND, Mangonui [sic; = Maunganui] Bluff, 11 March 1976, K.A.J. Wise (AMNZ); 1 female, same data as holotype (and taken in copulo with it); 1 female, AK, Whatipu, 26 February 1979, J.S. Dugdale (NZAC).

Material examined. Type series only.

— / ND, AK / —

Remarks. *A. tricoloratus* is a member of the *A. nebulosus*-group, which is discussed further under *nebulosus*.

Anabarhynchus waitarerensis new species

Figures 198–200, 306, 307

Male. Head. Eyes separated in front of anterior ocellus by twice its width. Frons uniformly brownish tomentose, protruding slightly in lower half; pile black; some setae nearly as long as scape. Face bare. Scape grey-black; flagellum blackish; terminal flagellar segments together slightly longer than half length of 1st flagellar segment. Occiput with about 50 black macrosetae on either side. Pile of lower occiput and genae white-yellow. Palpi grey-brown.

Thorax. Macrosetae: np 4, sa 2, pa 1, dc 2, sc 2; all setae black. Mesonotum pale grey-brown tomentose, with 3 dark brownish stripes; pile moderately long, exclusively black. Scutellum brown-black with greyish margin; pile white-yellow. Prosternal furrow, sternopleura, and hind surface of middle femora without pile. Pleura and coxae greyish tomentose.

Legs. Fore femora with 1 or 2 av macrosetae; middle femora without macrosetae; hind femora with 1 av and 1 pv. Femora blackish; pile of hind femora white-yellow, with blackish setae intermixed on dorsal surface towards apex; pile on ventral surface semi-erect, about one-fourth as long as femoral width. Tibiae brownish, gradually darkened towards apices.

Wings dark grey hyaline; veins brown-black; stigma pale brownish. Halteres dirty yellowish, blackened around base of knob.

Abdomen. Tergites with blackish anterior bands nearly reaching posterior margin in midline; posterolateral areas greyish tomentose. Pile black and appressed on blackish areas, white-yellow and more erect on remainder. Sternites greyish with white-yellow pile.

Terminalia (Fig. 198–200) brown-black, with a mixture of black and pale setae. Epandrium (Fig. 198) 1.5x as wide as long; cerci small, apparently free of pile. Gonocoxites (Fig. 199) approximated ventrally, with clearly demarcated borders; hypandrial element discrete. Outer style short, thick-bodied, with apex sharp; inner style with dorsal surface straight. Aedeagus (Fig. 200) with phallic part a long, thin, gradually narrowing tube ending in a sharp apex.

Female. As for male except as follows. Eyes separated by 3x width of anterior ocellus. Frontal tomentum darker grey-brown. Mesonotum appearing darker, and posterior part of mesonotum and scutellum with a brownish pile. T4–7 with exclusively stiff blackish pile.

Terminalia. S8 in face view (Fig. 306) with mid posterior part slightly raised, surrounded by small demelanised areas, in profile (Fig. 307) with a very slight incurvation of posterior half; pile weak, sparse. Third A1 seta about 7x as long as wide, blunt-tipped; 7 or 8 A1 setae per side. Longest A2 seta about 1.2x as long as 3rd A1 seta; 6 or 7 A2 setae per side.

Dimensions. Body length 7–9 mm, wing 6.6–7.2 mm.

Type data. Holotype: male, WN, Waitarere Beach, Levin, 6 January 1964, R.G. Ordish (NMNZ).

Paratypes: 1 female, same data as holotype (NMNZ).

Material examined. Type specimens only.

— / WN / —

***Anabarhynchus westlandensis* new species**

Figures 201–203, 302, 303

Male. Head. Eyes separated in front of anterior ocellus by about 3x its width. Frons grey to grey-brown tomentose,

slightly protruding in lower part; pile black; setae about as long as scape. Face bare. Scape grey-black; flagellum blackish; terminal flagellar segments together about one-fourth as long as 1st segment. Occiput with 40–50 rather weak black macrosetae on either side. Pile of lower occiput and genae whitish. Palpi greyish.

Thorax. Macrosetae: np 3 or 4, sa 1 or 2, pa 1, dc 1 or 2, sc 2; all setae black. Mesonotum pale grey-brown; pattern of dark brown tomentum composed of a narrow median stripe, a broader lateral band in front of suture, and a horseshoe-shaped spot behind suture; pile short, composed of black and white setae. Scutellum greyish; pile long, whitish. Prosternal furrow, sternopleura, and posterior surface of middle coxae without pile. Pleura and coxae greyish.

Legs. Fore femora with 1 or 2 pd macrosetae and 1 av; middle femora with 1–3 pv; hind femora with 1 av and 0–2 pv. Femora and tibiae grey-black. Pile of hind femora uniformly whitish, soft, appressed to semi-erect.

Wings grey hyaline, with 12 darker areas of varying size in centre of cells; veins brown-black; R₁ with minute setae on section passing through brownish stigma. Halteres with knob pale yellow.

Abdomen grey-black on anterior parts of T2–4, greyish on remainder and on following tergites; pile blackish, appressed on dark areas, whitish on the remainder. Sternites greyish with whitish pile.

Terminalia greyish with black pile. Epandrium (Fig. 201) about 1.6x as wide as long; cerci apparently free of pile. Gonocoxites (Fig. 202) with wide, dark zones of fusion with hypandrial element. Outer style remarkably thick-bodied. Aedeagus (Fig. 203) with phallic part longer and more downward-directed than in other *nebulosus*-group species.

Female. As for male except as follows. Eyes separated by about 4.5x width of anterior ocellus. Anterior bands of T2–4 less distinct; pile of T5–8 exclusively black.

Terminalia (Fig. 302, 303) with sets of pile partially interwoven (as usual in the *nebulosus*-group; see also Fig. 218 and 274). Longest A1 seta about 8x as long as wide; 9 A1 setae per side. Longest A2 seta about 1.6x as long as 3rd A1 seta; 5–7 A2 setae per side.

Dimensions. Body length 8–10 mm, wing 6.5–8.2 mm.

Type data. Holotype: male, WD, Ship Creek N of Haast, 8 December 1977, E.I. Schlinger (CISB).

Paratypes: 1 male, 5 females, same data as holotype (CISB, NZAC, ZMKD); 1 male, 1 female, WD, Gladstone, 6 October 1971, J.S. Dugdale (NZAC); 1 female, WD, Okarito Beach, 12 February 1976, R.A. Harrison (LCNZ).

Material examined. Type series only.

— /WD /—

Remarks. *A. westlandensis* is a member of the *A. nebulosus* species-group; see Remarks under *nebulosus*.

Anabarhynchus wisei new species

Figures 304, 305

Male. Unknown.

Female. Head. Eyes separated in front of anterior ocellus by 5.5x its width. Frons grey-brown tomentose, strongly protruding over entire length; frontal pile black, longer than scape. Face with some pile. Scape grey-black; (rest of antennae missing). Occiput with about 25 strong black macrosetae on either side. Pile on lower occiput and genae whitish. Palpi brownish.

Thorax. Macrosetae: np 4 or 5, pa 2 or 3, sa 1, dc 1, sc ?; all setae black. Mesonotum discoloured but probably uniformly grey-brown; pile rather long, erect, black; whitish, more appressed pile present anteriorly. Prosternum without pile in furrow, with a pair of strong black macrosetae laterally among long whitish pile. Sternopleura without pile. Posterior surface of middle coxae with some long whitish pile. Pleura and coxae greyish tomentose.

Legs. (Fore and middle legs and right hind leg missing in holotype.) Left hind femur with 2 av and 3 pv macrosetae; pile on ventral surface whitish, erect; setae up to 0.6x as long as femoral width; pile on dorsal surface whitish, appressed, semi-scaly. Hind tibia brownish.

Wings grey-brown hyaline; veins and stigma brownish. Halteres brown-black.

Abdomen. Dorsum appearing uniformly dark greyish (in well preserved specimens anterior parts of T2–4 probably appearing darker). T5–7 with stiff black pile. Sternites greyish with whitish pile on S2–4, black pile on S5–7.

Terminalia. S8 in face view (Fig. 304) nearly circular in outline, with a strongly depressed transverse area bordered by a multiserial lateral group of strong setae, in profile (Fig. 305) with a strong postmedian incurvation. Third A1 seta about 3x as long as wide, blunt-tipped to slightly spatulate; 8 A1 setae per side. Longest A2 seta about 2.2x as long as 3rd A1 seta; 7 or 8 setae per side.

Dimensions. Body length 14.2 mm, wing 11.0 mm.

Type data. Holotype: female, CO, Routeburn, 25 December 1914, ? collector (AMNZ).

Material examined. Holotype only.

— /CO /—

Remarks. *A. wisei* is unique among New Zealand therevids in having a pair of strong prosternal macrosetae. This should ensure its easy recognition among newly collected material.

Megathereva new genus

Type species *Bibio bilineata* Fabricius, 1775, here designated.

Diagnosis. Very large, heavily built, blackish therevids characterised by the following autapomorphic character states relative to *Anabarhynchus*: male S10+11 forming a complex, bowl-shaped sclerite below epandrium; aedeagus nearly straight, dorsoventrally extended; female S8 with lateral 'slits' in posterior margin; female T10 with a high number of A1 setae, 8–13 on either side; pupa with a complex system of wrinkles posteriorly, and lacking the usual pair of terminal spines.

Description. Head. Eyes in male separated by 2–3x width of anterior ocellus, in female by 3–4x width of ocellus. Frons with a rich pile. Occiput with 40–50 uniform black macrosetae on either side. Face without pile. Scape (Fig. 320–323) of varied length, with rich pile. Proboscis with large labella. Palpi simple, 1-segmented.

Thorax with numerous macrosetae: np 5–12, sa 2 or 3, pa 1 or 2, dc 2–4, sc 2 or 3. Prosternum with pile in median furrow. Sternopleura and posterior surface of middle coxae without pile. Mesonotum black with 2 white-grey stripes; pile short, uniform.

Legs. Femora with from 1 av macroseta to several (sometimes absent from middle femora); hind femora also with 1 or 2 pv. Femora black; pile uniform, erect, whitish or blackish. Tibiae black or bicoloured black and brown.

Wings greyish hyaline; costal cell and stigma sometimes blackened; vein R_1 without setae; cell m_3 broadly open.

Abdomen broadly conical, black, with greyish tomentum on extreme lateral parts of tergites and sternites. Pile moderately long, dense, whitish or blackish.

Male terminalia. Epandrium about twice as wide as long; lateral parts hanging; cerci oval, about half as long as epandrium; pile long, weak. S10+11 forming a complex, strongly sclerotised, bowl-shaped sclerite beneath epandrium; anterior margin of 'bowl' dorsoventral in position, standing as a wall situated at one-third of epandrial length from anterior margin; anteriorly with a weak connection to anterior margin of aedeagus. Gonocoxites with posterior

lobe lamellate. Hypandrium forming a large band-shaped sclerite appearing as if 'glued' on to anteroventral parts of gonocoxites, consequently creating a system of lines as shown in Fig. 317 and leaving a triangular, more hyaline area in middle. Outer style with an internal subapical process, species-specific in shape. Aedeagus compact; phallic part nearly straight, dilated distally, about as long as dorsal apodeme; sperm-tube showing through, terminating in a weakly sclerotised, crater-shaped, upturned apex. Ventral apodeme spoon-shaped. T8 moderately constricted; S8 rectangular.

Female terminalia. S8 squarish; posterior lobe forming a narrow or wider, pilose median keel lying within a melanised area of varying shape; posterior corners with a deep longitudinal 'slit' covered by a weakly sclerotised membrane some distance from lateral margin. Furca diamond-shaped, with a pair of lateral flake-shaped lobes on posterior frame. Tergite 10 with 8–13 A1 setae and 6 or 7 A2 setae on either side.

Larva. No larval material was available to me. The larva of a *Megathereva* was briefly described by Hudson (1950, p. 62) and depicted in colour, along with the adult and the pupa. From the illustration of the adult (pl. II, fig. 5) it is obvious that Hudson was dealing not with *Anabarhynchus bilineatus* (now in *Megathereva*) but with the species described below as *Megathereva atritibia*.

Hudson's description of the *M. atritibia* larva is confined to colour characters. It is therefore not possible to give any diagnostic characters by which it can be distinguished from the larva of *Anabarhynchus fasciatus*, which was described and illustrated in some detail by English (1950). The total length of the *M. atritibia* larva was given as 42 mm.

Pupa (Fig. 19–21, 23). Description based on a pupa and exuviae of *Megathereva albopilosa* from Katiki Beach, DN. Similar to pupa of *Anabarhynchus*, with the following differences: prominence proximal to anterior base of antennal sheaths longer, having the character of a process (Fig. 19); spine of alar process very long, arising from a very heavy base; dorsal row of spines of abdominal segment 2 (Fig. 23) and succeeding segments all hair-like, not intermixed with thorn-like spines; ventral row of spines weak, hair-like, 9–12 on either side, around midline interrupted by a row of small, thorn-like spines; terminal segment with a complex system of furrows (Fig. 20, 21); terminal pair of spines absent. Total length of pupa about 13 mm, of exuviae about 19 mm.

Remarks. *Megathereva* is erected to include three closely related species, and may contain a few more. Autapomorphic characters for this obviously monophyletic group are listed under the diagnosis, above. A sister-group to *Mega-*

thereva is not easily discernible. I have examined most described and many undescribed Australian and Neotropical species of the *Anabarhynchus*-group, and it seems certain that *Megathereva* is endemic to New Zealand and that its sister-group should be searched for among the New Zealand stock of *Anabarhynchus*. Attention should be given to *A. atratus*, which has a similar amalgamation of the hypandrium and gonocoxites, and in which the phallic part of the aedeagus is relatively wide (Fig. 34, 35).

Hudson (1950) gives the following biological information on the *atritibia* larva: "... lives in the sand just above high water mark and may sometimes be found under logs, or seaweed. It is extremely active and when discovered retreats into the sand with extraordinary rapidity. Rapid motion is effected by digging the sharp pointed head into the sand with great violence, and the larva can progress over a smooth surface at a great rate by similar means. It is almost certainly carnivorous, and probably a cannibal, but I have never succeeded in seeing the larva eat anything."

Megathereva albopilosa new species

Figures 19–21, 23, 308–310, 314, 320

Male. Head. Eyes in front of anterior ocellus separated by about 2.5x its width. Frons slightly protruding in lower third, greyish tomentose, with middle of lower part white-grey tomentose; pile black; longest setae about 0.8x as long as scape. Scape (Fig. 320) about twice as long as wide at middle, incrassate at base, shorter than flagellum; pile on ventral surface dense, strong; longest setae nearly twice as long as width of scape at middle. Pile of lower occiput composed of mixed black and white setae, of genae and palpi whitish.

Thorax. Mesonotum brown-black with 2 white-grey tomentose stripes less sharply demarcated than in *atritibia* and *bilineata*; lateral areas with more extensive white-grey tomentum than in these species; pile black, longer than in these species. Prosternal pile whitish.

Legs. Fore femora with 1–3 av macrosetae; middle femora without av, or with 1 or 2 hair-like av; hind femora with 1–4 thin av but no pv. Femora black. Tibiae bicoloured, bright yellow-brown for more than proximal two-thirds, black distally. Coxal pile whitish or mixed blackish and whitish.

Wings greyish hyaline; veins, stigma, and basal part of costal cell brownish. Halteres blackish.

Abdomen blackish; pile short and black on disc, longer and whitish on lateral parts.

Terminalia as in Fig. 308–310. Gonocoxite (Fig. 309) with an evenly rounded posterior extension, i.e., outer

corner not more projecting than inner corner. Outer style more slender than in *atritibia* and *bilineata*.

Female. As for male except eyes separated by about 4x width of anterior ocellus.

Terminalia. S8 as in Fig. 314; posterior lobe less protruding than in other 2 species, distinctly bilobed; setae moderately strong. Third A1 seta about 10x as long as wide, moderately sharp-pointed; 11–13 A1 setae per side. Longest A2 seta about 1.2x as long as 3rd A1 seta; 6 or 7 A2 setae per side.

Dimensions. Body length 13–16 mm, wing about 12 mm.

Type data. Holotype: male, DN, Katiki Beach, 3 December 1977, E.I. Schlinger (NZAC).

Paratypes: 1 male, 1 female, NN, Farewell Spit, 22 February 1923, H. Hamilton (NMNZ); 1 male, 1 female, NN, Nelson, January 1928, A. Tonnoir (NZAC); 1 female, NN, Tahuma, 28 December 1941, ? coll. (NZAC); 1 male, BR, Punakaiki, 30 October 1970, Ento. Dept. Field Trip (LCNZ); 1 female, WD, Whataroa R., beach N of mouth, 6 December 1976, R.P. Macfarlane (NZAC); 1 female, MC, Christchurch, ? date, H. Clark (CMNZ); 1 male, MC, New Brighton, 25 October 1959, R.E. Leech (BPBM); 1 female, MC, Banks Pen., Purau Bay, 3 November 1974, R.M. Emberson (LCNZ); 1 male, 12 females, 2 pupae, same data as holotype (CISB, NZAC, ZMKD); 2 males, 1 female, Warrington Beach, sand dune area, E.I. Schlinger (CISB, ZMKD); 1 female, SL, Tautuku, 5 December 1989, ? coll. (LCNZ); 5 females, Catlins, Waipati Beach, 7 February 1982, S.P. Warner (LCNZ); 1 female, SI, Stewart I., 1 February 1973, H. Hayakawa (ZMKD); 1 female, SI, Golden Bay, January 1960, M.N. Watt (NMNZ); 1 male, SI, SW Easy Cove, 25 January 1955, R.K. Dell & B.A. Holloway (NMNZ).

Material examined. Type series only.

— / NN, BR, WD, MC, DN, SL / SI / —

Megathereva atritibia new species

Figures 311–313, 315, 321

Male. Head. Eyes in front of anterior ocellus separated by 2.4–2.5x its width. Frons distinctly protruding in lower half, mostly dull blackish, with a bare area in middle of lower part greyish tomentose; pile black; setae about half as long as scape. Scape (Fig. 321) about 2.3x as long as wide and as long as flagellum. Antennae black; pile on ventral surface of scape dense, strong; longest setae about

1.5x as long as width of scape. Pile of lower occiput, genae, and palpi black.

Thorax. Mesonotum dull black with 2 very distinct white-grey tomentose stripes; posterior surface of scutellum greyish tomentose; mesonotal and prosternal pile black.

Legs. Fore femora with 2–4 av macrosetae; middle femora with 1 or 2 strong av; hind femora with 3–5 av and 1 or 2 pv. Femora and tibiae deep black; pile black. Coxal pile black.

Wings greyish hyaline; costal cell, veins, and stigma brown-black. Halteres blackish.

Abdomen shining black; pile black.

Terminalia as in Fig. 311–313. Gonocoxite (Fig. 312) with outer posterior corner less protruding than inner corner relative to *bilineata* (cf. Fig. 317). Outer and inner styles (Fig. 312) about equal, the former with a small triangular lobe.

Female. As for male except eyes separated by about 4x width of anterior ocellus.

Terminalia. S8 as in Fig. 315; posterior lobe bulb-shaped, strongly protruding; setae moderately strong. Third A1 seta about 12x as long as wide, blunt-ended; 8 or 9 A1 setae per side. Longest A2 seta about as long as 3rd A1 seta; 6 or 7 A2 setae per side.

Dimensions. Body length 15–18 mm, wing about 14 mm.

Type data. Holotype: male, WN, Wellington, ? date, G.V. Hudson, "*bilineatus* Hutton det." (CMNZ).

Paratypes: 1 female, WI, Wanganui, ? date, ? coll. (NZAC); 1 female, WI–WN, Tangimoana, 15 February 1958, R.A. Cumber (NZAC); 1 male, WI–WN, Manuwatu R. flats, 13 January 1980, P.J. Watts (NZAC); 1 female, WN, Waitarere, 30 December 1953, R. Ordish (ZMKD); 1 female, WN, Levin, Waitarere Beach, 16 January 1960, R.G. Ordish (NMNZ); 1 male, WN, Levin, Waitarere Beach, 5 January 1961, R.G. Ordish (NMNZ); 1 female, WN, Levin, Waitarere Beach, 6 January 1964, R.G. Ordish (NMNZ); 1 male, WN, Wellington, June [!] 1895, G.V. Hudson (IFPE); 1 male, WN, Wellington, 21 February 1911, F.W. Hutton (ZMKD); 2 females, WN, Fitzroy Bay beach, 28 November 1961, R.G. Ordish & J. McMillan (NMNZ).

Material examined. Type series only.

— / WI, WN / —

Remarks. Hudson (1950) made some observations on this species; see introduction to genus, p. 67.

It is noteworthy that *atritibia* occurs sympatrically with *bilineata* at Waitarere Beach north of Wellington.

Megathereva bilineata (Fabricius)

Figures 316–319, 322

bilineata Fabricius, 1775 (*Bibio*). Holotype female, New Zealand.

Male. Head. Eyes in front of anterior ocellus separated by about twice its width. Frons distinctly protruding in lower half, mostly dull blackish, with a bare area in middle of lower part greyish tomentose; pile black; setae about half as long as scape. Scape (Fig. 322) about 3x as long as its width at middle, longer than flagellum. Antennae black; pile on ventral surface of scape dense, strong; longest setae about 1.8x as long as width of scape. Pile of lower occiput, genae, and palpi black.

Thorax. Mesonotum dull black with 2 very distinct, white-grey tomentose stripes; notopleura and a strip above humeri slightly white-grey tomentose; posterior surface of scutellum greyish tomentose. Thoracic pile exclusively black. Prosternal pile black.

Legs. Fore femora with 2–4 av macrosetae; middle femora without macrosetae; hind femora with 2 or 3 av and 1 or 2 pv. Femora black, shining; pile black. Tibiae markedly bicoloured, bright yellow-brown for more than proximal half, black distally. Coxal pile black.

Wings greyish hyaline; costal cell, veins, and stigma brown-black. Halteres blackish.

Abdomen shining black; pile black.

Terminalia as in Fig. 316–319. Gonocoxite (Fig. 317) with outer posterior corner distinctly more protruding than inner corner. Outer style (Fig. 317) strong relative to inner style; subapical lobe large, triangular.

Female. As for male except eyes separated by about 3x width of anterior ocellus.

Terminalia. S8 similar to that of *atritibia* (see Fig. 315); posterior lobe bulb-shaped, strongly protruding; setae very strong, stubby. Third A1 seta about 14x as long as wide, sharp-pointed; about 10 A1 setae per side. Longest A2 seta about 1.1x as long as 3rd A1 seta; 6 or 7 A2 setae per side.

Dimensions. Body length 15–18 mm, wing about 14 mm.

Type data. The female holotype (BMNH, Banks Collection) was checked by Mr J.E. Chainey. It is in poor condition, but the left wing and left hind leg are enough to secure its identification. It was collected during one of Cook's voyages, probably on a beach in the Auckland area.

Material examined. Holotype, plus 9 non-type examples: 1 male, AK, Auckland, Mar 1933, ? coll. (AMNZ); 1 male, AK, Auckland, Nov 1955, Gray (NZAC); 2 males, AK, Motuihe I. nr Auckland, 1916–1919, J. Henniger (BPBM, ZMKD); 1 female, AK, Clarks Beach, 3 Feb 1953, K.A.J. Wise (NZAC); 1 female, CL, Whangapoua, 27 Dec 1940, W. Barnard (NZAC); 1 male, WN, Waitarere Beach, 5 Jan 1961, M.A. Ordish (NMNZ); 1 male, NN, Kohaihai R. mouth, 21 Jan 1980, J.W. Early (LCNZ); 1 female, KA, Oaro, scashore, 10 Mar 1968, P. Bahadur (LCNZ).

— / AK, CL, WN / NN, KA / —

Remarks. A female from NC, Nape Nape Scenic Reserve nr Hurunui R., 17 Nov 1977, E.I. Schlinger (ZMKD) probably represents an undescribed species closely allied to *bilineata*. It has bicoloured tibiae and black thoracic pilosity like *bilineata*, but the scape (Fig. 323) is much shorter (about twice as long as its width at the middle), the costal cell is greyish hyaline as for the rest of the wing, and the setae of S8 seem weaker than in *bilineata*. It is clearly different from the other South Island *Megathereva*, *M. albopilosa*.

Genus *Ectinorhynchus* Macquart

Ectinorhynchus Macquart, 1850: 407 (103). Type species *Thereva variabilis* Macquart, 1846, by original designation.

Diagnosis. Rather small to medium-sized, slender-bodied therevids (Fig. 2) characterised by the following autapomorphic characters: scape as long as 1st flagellomere or longer; hypopleural pile absent; aedeagus with phallic part of a complex bulbous shape; male S10 usually entirely membranous; female T10 with relatively few A1 setae, 5–7 per side.

Description. Eyes in male separated by 3.5–4.5x width of anterior ocellus, in female usually by slightly more. Scape cylindrical, 2–3x as long as wide; 1st flagellomere as long as scape or shorter; flagellar style with 1 or 2 segments plus a terminal spine. Palpus 1-segmented. Curved, elongate postocular macrosetae usually present.

Thoracic macrosetae: np 3–8, sa 1 or 2, pa 1, dc 0–4, sc 1 or 2. Prosternum without pile in median furrow. Hypopleural pile absent. Pleura usually with a pattern of tomentose areas and more shiny, brownish or blackish areas. Femora without macrosetae, or hind femora with 1 or 2 short av at apex; pile simple, short, erect. Wings often with darker transverse bands. Abdomen slender; dorsum with more or less distinct tomentum.

Epandrium rather narrow; ventral epandrial sclerite usually present only as a small sclerite (= S11) below cerci, with S10 membranous. Gonocoxites often elongate, with posterior projection(s); ventral margins sometimes separated entirely (as in Fig. 334), or separated by a hyaline area (as in Fig. 325), or touching (as in Fig. 330), or fused for a short distance (as in Fig. 338). Hypandrium well developed. Outer style present or absent; inner style (= gonostyle) well developed. Aedeagus with phallic part short, wide; dorsal and ventral apodemes short, the latter forked.

Female: S8 very simple, with a deep slit into posterior margin, with or without depressed areas; T10 with 5–7 A1 setae and 7–12 A2 setae.

Immature stages. The larvae of New Zealand *Ectinorhynchus* species are unknown. English (1950) describes in some detail the larva of *E. variabilis*, which was collected in garden soil at Rose Bay and Woolwick in New South Wales. The main diagnostic character separating the larva of *Ectinorhynchus* from that of *Anabarhynchus* is that the two papillae in the lateral white area of the head are placed one well behind the other in *Ectinorhynchus*, whereas in *Anabarhynchus* one is placed above the other, or nearly so. The pupa of *Ectinorhynchus* is easily distinguished from that of *Anabarhynchus* by the lack of a spine on the alar process. *Ectinorhynchus* and *Anabarhynchus* pupae both have a terminal pair of slender spines, and are thus quite distinct from pupae of *Megathereva* (cf. Fig. 20, 21).

Remarks. *Ectinorhynchus* includes eleven Australian species in addition to the four New Zealand species treated here (Irwin & Lyncborg 1989). As the Australian species are in need of revision, it is not possible to comment on phylogenetic relationships. The New Zealand species may or may not form a monophyletic group.

Ectinorhynchus castaneus (Hutton)

Figures 324–328

castaneus Hutton, 1901: 26 (*Anabarhynchus*). Kröber, 1932: 138 (*Ectinorhynchus*). Holotype female, New Zealand.

Male. Head. Eyes separated in front of anterior ocellus by about 3.5x its width. Frons partly subshiny above, grey-brown tomentose below, but without clear demarcation; pile long, black throughout. Antennae blackish; scape and 1st flagellar segment about equal in length and width, both about twice as long as wide; terminal flagellar segments together about one-third as long as 1st segment, composed of 2 segments plus a short apical spine. Postocular macrosetae very numerous, long, thin; upper setae elongate, anteriorly directed.

Thorax. Macrosetae: np 5–8 (usually arranged in 2 irregular rows), sa 1 or 2, pa 1, dc 2–4 (gradually decreasing in size anterad, and therefore difficult to distinguish from other pile), sc 2 (lateral pair weaker than subapical pair). Mesonotum in anterior view golden grey and grey-brown tomentose, rather unpatterned, in posterior view subshiny to shiny black with 2 rather wide grey-brown tomentose stripes; pile long, erect, black. Scutellum and pleura grey-brown tomentose; pile long, black, present on scutellum, mesopleuron, and sternopleuron.

Legs. Fore and middle femora without macrosetae; hind femora with 1 or 2 av. Femora yellow-brown to piceous brown, shiny, with rather long pile of simple, erect, black setae. Tibiae concolorous with corresponding femora.

Wings grey-brown, slightly mottled by darker areas along veins, especially cross-veins. Halteres brown-black.

Abdomen. Tergites intensely white-grey tomentose on disc; lateral parts of tergites and sternites shiny yellow-brown; pile whitish.

Terminalia. Epandrium and gonocoxites yellow-brown, the former with a blackish median stripe. Epandrium (Fig. 324) slightly wider than long; pile black, long, rather sparse. Cerci oval; a well sclerotised sclerite (representing S11) present below cerci; remainder of ventral epandrial sclerite not sclerotised. Gonocoxite (Fig. 325) with a dentate posterior extension, on dorsal margin with a non-articulated awl-shaped process possibly representing outer style or perhaps a new structure (in which case, outer style absent). Anterior parts of gonocoxites connected via a hyaline area behind band-shaped hypandrium. Inner style (Fig. 326) upcurved, ending in a sharp apex. Aedeagus (Fig. 327) with phallic part very short and compact, dorsally with 2 angular lobes; ventral apodeme split, forming 2 narrow, spoon-shaped sclerites.

Female. As for male except as follows. Eyes separated by 5.0–5.5x width of anterior ocellus. Frons usually entirely tomentose; pile shorter, about half as long as scape. Postocular macrosetae fewer, shorter. Tergites 2–5 thinly white-grey tomentose on disc; lateral parts of these tergites and rest of abdomen shiny chestnut-brown to black.

Terminalia. S8 in face view (Fig. 328) 2.5x as long as wide, with a deep simple slit in posterior margin, in profile nearly straight. Third A1 seta about 6x as long as wide; 6 or 7 A1 setae per side. Longest A2 seta about twice as long as 3rd A1 seta; 10–12 A2 setae per side.

Dimensions. Total length 9.5–10.6 mm, wing 7.8–8.2 mm.

Type data. The holotype female (CMNZ) is labelled "Christchurch/H. Clark" and "Type". There is a topotypic

female paratype in the same collection. Hutton (1901) also reports *castaneus* from Wellington, but I have not been able to locate any specimens labelled accordingly.

Material examined. Holotype and paratype, plus 21 non-type examples: 1 female, DN, Leith Saddle, broadleaf forest, 4–14 Feb 1976; 3 females, same loc. but Feb 1977; 1 male, 1 female, same loc. but 10–30 Apr 1977; 1 male, same loc. but 5 Jan 1990, all A.C. Harris (OMNZ, ZMKD); 1 male, FD, L. Manapouri, 4000' [1200 m], ? date, S. Lyndsay (BMNH); 1 female, FD, Hunter Mtns, Mt Burns, 1300 m, Jan 1970, J. McBurney (NZAC); 1 female, FD, Mt Burns, 1370 m, 3 Feb 1982, C.A. Muir (LCNZ); 1 male, 1 female, FD, Mt Cleughearn, 3250' [980 m], 13 Jan 1916 (NZAC); 1 male, 1 female, FD, Mt Cleughearn, 3500' [1050 m], 23 Jan 1917, ? coll. (NZAC); 1 male, SI, 1 Feb 1973, H. Hayakawa (ZMKD); 1 male, SI, 5 Jan 1976, A.C. Harris (OMNZ); 5 males, SI, Lee Bay, 22–29 Jan 1976, A.C. Harris (OMNZ, ZMKD).

— / MC, DN, FD / SI / —

Ectinorhynchus cupreus (Hutton)

Figures 329–332

cupreus Hutton, 1901: 27 (*Anabarhynchus*). Kröber, 1932: 139 (*Ectinorhynchus*). Holotype female, New Zealand.

Male. Head. Eyes separated in front of anterior ocellus by about 3.5x its width. Frons black, shiny below, thinly tomentose above; lower part in profile strongly raised; pile short, sparse, black. Antennae blackish; scape cylindrical, about 4x as long as wide; 1st flagellar segment about three-fourths as long as scape, of equal width, with numerous setae; flagellum terminating in a small globose segment and a minute subapical spine. Postocular macrosetae short, weak, about 35 on either side; upper setae elongate. Lower occiput and genae greyish tomentose.

Thorax. Macrosetae: np 3 or 4, sa 1, pa 1, dc 0, sc 1; all setae black, weak. Mesonotum blackish, with 2 ill marked tomentose stripes; humeri and notopleura dark brownish; pile short, sparse, black. Pleura longitudinally striped: a white tomentose stripe stretching over upper part of sternopleuron; areas above this stripe (including entire mesopleuron) shiny brown-black; areas below stripe, i.e., lower sternopleuron and hypopleuron, subshiny black. Pleural pile sparse, whitish.

Legs. Femora without macrosetae, brown-black. Tibiae dark brownish.

Wings grey-brown, with apical part and a band from stigma over discal cell darker brown; veins and stigma brown-black. Halteres blackish.

Abdomen. Tergites brown-black to black when seen from behind, but from in front with a dense white tomentum. Sternites brownish. Abdominal pile sparse, whitish.

Terminalia polished brown to black; pile black. Epandrium (Fig. 329) remarkably long and narrow, only about half as wide as long; cerci small; ventral epandrial sclerite (S10+11) well developed, forming a narrow band-shaped sclerite to near anterior margin of epandrium. Gonocoxite (Fig. 330) with a simple posterior extension, its ventral inner lobe very large; inner lobes touching in midline, behind narrow hypandrium. Outer style (Fig. 330) small, finger-shaped; inner style extremely elongate. Aedcagus (Fig. 331) compact, nearly straight, the 2 dorsal lobes coarsely dentate.

Female. As for male except eyes separated by about 4.4x width of anterior ocellus, and abdomen with only a very thin whitish tomentum.

Terminalia. S8 in profile nearly straight, in face view (Fig. 332) gradually tapering posterad, with posterior lobe clearly demarcated, medially with a pair of oval, depressed areas and with a penial guide structure present in midline. Third A1 seta about 6x as long as wide, sharp-pointed; 5 or 6 A1 setae per side. Longest A2 seta about twice as long as 3rd A1 seta; about 10 A2 setae per side.

Dimensions. Body length 7.8–9.2 mm, wing 5–7 mm.

Type data. The holotype female (CMNZ) is well preserved and is labelled "Wellington / G. V. Hudson".

Material examined. Holotype, plus 21 non-type examples: 1 male, 1 female, CL, Little Barrier I., Te Titoki Point, 28 Nov 1954, R.A. Harrison (NZAC); 1 male, WN, Wellington, Botanical Gardens, 15 Jan 1931, E.A. Plank; 1 male, WN, Lyall Bay, 13 Jan 1922, D.M. [Miller?] (BMNH); 5 males, SD, Stephens I., 14–28 Jan 1933, E.S. Gourlay (NZAC); 1 male, 2 females, SD, Stephens I., Feb 1971, J. McBurney (NZAC); 1 female, SD, Trio I., 17 Jan 1922, R.J. Tillyard (NZAC); 3 males, 1 female, 1 pair in copulo, Trio I., 20 Dec 1954, G.W. Ramsay (NZAC, ZMKD); 1 male, NN, Hope, 28 Feb 1980, R.P. Macfarlane (NZAC); 1 male, NN, Dun Mtn, 6 Jan 1921, A. Philpott (NZAC).

— / CL, WN / SD, NN / —

Ectinorhynchus furcatus new species

Figures 333–336

Male. Head. Eyes separated in front of anterior ocellus by about 4.5x its width. Frons (discoloured in holotype) slightly raised over entire length; pile black; longest setae longer

than scape; lower middle part devoid of pile. Antennae black; scape and 1st flagellar segment about equal in length and width, both twice as long as wide; terminal flagellar segments together one-third as long as 1st segment, comprising 2 segments plus a minute apical spine. Postocular macrosetae black, about 50 on either side; a few upper setae elongate. Pile of lower occiput and genae long, whitish.

Thorax. Macrosetae: np 6 or 7, sa 1 or 2, pa 1, dc 2, sc 2; setae long, black. Mesonotum brown-grey with 2 white-grey tomentose stripes; pile rather long, black; scutellum discoloured. Pleura entirely greyish tomentose.

Legs. Fore and middle femora without macrosetae; hind femora with 1 av. Femora brownish, blackened on dorsal surface of fore and middle femora and on apical part of hind femora; pile uniformly short, black. Tibiae brownish, slightly darkened apically.

Wings markedly brownish tinged; stigma and areas around cross-veins brown-black. Halteres brown-black.

Abdomen. Tergites appearing whitish tomentose in anterior view; discs blackish when seen from behind, and lateral areas brownish; sternites brownish; abdominal pile rather long, white.

Terminalia brownish; epandrium with a blackish median stripe. Epandrium (Fig. 333) about as long as wide; pile black, long. Cerci oval with a well sclerotised sclerite (representing S11) below; remainder of ventral epandrial sclerite unsclerotised. Gonocoxite (Fig. 334) on dorsal margin with a non-articulated bifurcate extension composed of a long, downcurved dorsal section and a short, pointed ventral section (Fig. 335). Gonocoxites connected only anteriorly via large hypandrium. Aedeagus with phallic part (Fig. 336) short, compact, with 2 rounded dorsal lobes beset with minute denticles.

Female. Unknown.

Dimensions. Body length about 10 mm, wing 8.6 mm.

Type data. Holotype: male, MB, L. Tennyson, 1220 m, 21 January 1976, A.R. Ferguson (NZAC).

Material examined. Holotype only.

— / MB / —

Remarks. *E. furcatus* is clearly the sister-species of *E. castaneus*. The most obvious synapomorphic character is the absence of an outer style and, compensating for this loss, the development of distal gonocoxal projections.

Ectinorhynchus micans (Hutton)

Figures 337–341

micans Hutton, 1901: 27 (*Anabarhynchus*). Kröber, 1932: 139 (*Ectinorrhynchus*). Holotype female, New Zealand.

Male. Head. Eyes separated in front of anterior ocellus by about 3.5x its width. Frons grey, grey-brown, or brown tomentose, lowered relative to eye in profile; pile black; setae short and sparse on upper part, longer and denser on 2 lateral areas of lower part. Antennae brownish; scape and 1st flagellar segment about equal in length and width; 2nd flagellar segment about 0.15x as long as 1st segment, with a short terminal spine. Occiput with 20–25 black macrosetae on either side. Lower occiput with whitish tomentum and long pale pile. Palpi blackish.

Thorax. Macrosetae: np 3 or 4, sa 1 or 2, pa 1, dc 0, sc 1; setae black. Mesonotum black with a pair of white-grey tomentose bands, these wide anteriorly and gradually narrowing posteriorly; posterior margin and scutellum white-grey tomentose; minor areas of golden brown tomentum sometimes present on lateral areas. Pleura pale grey tomentose except for polished lower anterior part of mesopleuron.

Legs. Femora without macrosetae; pile short, sparse. Fore femora yellowish in proximal half, blackish distally; middle and hind femora yellowish in about proximal two-thirds, blackish distally.

Wings grey-brown tinged, with more intensely brownish areas around cross-veins; veins and stigma brown-black. Halteres brown-black.

Abdomen. Tergites black, often a little brownish on extreme lateral part; dorsum of T2–5 with a thin white-grey tomentum, remaining tergites shining. Pile very sparse, practically absent from tomentose parts of T2–5. Sternites yellowish to brown-black.

Terminalia shiny brown-black to black; pile blackish. Epandrium (Fig. 337) slightly narrower than long; pile evenly distributed; cerci small. Gonocoxites (Fig. 338) truncate posteriorly, ventrally fused for a short distance; hypandrial element narrowly triangular. Outer style (Fig. 338, 339) bifurcate, composed of a small lateral section and a long posteroventrally directed inner section, both sections beset with minute dentation; inner style complex in shape. Aedeagus (Fig. 340) with a pair of ventral lobes; dorsal and ventral apodemes short.

Female. As for male except as follows. Femora yellowish, only slightly darkened apically. Abdomen paler, with tergites brown-black to yellow-brown, and with a narrow tomentose stripe on T2–5. Sternites yellowish.

Terminalia. S8 in face view (Fig. 341) nearly circular, with a deeply incised posterior lobe, in profile slightly

curved; pile evenly distributed, long anteriorly, short posteriorly. Third A1 seta about 6X as long as wide; 6 or 7 A1 setae per side. Longest A2 seta about twice as long as 3rd A1 seta; 7 or 8 A2 setae per side.

Dimensions. Body length 10–11 mm, wing 8.0–8.6 mm.

Type data. The type specimens (CMNZ) consist of a female labelled in red "Type" and a male labelled in blue "Paratype"; the female is consequently to be regarded as the holotype. Both are in good condition, and are labelled "Wellington / G.V. Hudson".

Material examined. Type specimens plus 87 non-type examples (51 males, 36 females; AMNZ, BMNH, CISB, CMNZ, LCNZ, NZAC, OMNZ, ZMKD).

—/TO, RI, WI, WN / BR, KA, MC, SC, MK, OL, CO, DN / —

REFERENCES

- Crosby, T.K.; Dugdale, J.S.; Watt, J.C. 1976: Recording specimen localities in New Zealand: an arbitrary system of areas and codes defined. *New Zealand Journal of zoology* 3: 69 + map.
- English, K.M.I. 1950: Notes on the morphology and biology of *Anabarhynchus fasciatus* Macq. and other Australian Therevidae (Diptera, Therevidae). *Proceedings of the Linnean Society of New South Wales* 75: 345–359.
- Fabricius, J.C. 1775: *Systema entomologiae*. Flensburg et Lipsiae. (32) + 832 pp.
- Hudson, G.V. 1892: An elementary manual of New Zealand and entomology. London. 128 pp.
- 1950: Fragments of New Zealand entomology. Wellington. 188 pp.
- Hutton, F.W. 1881: Catalogues of the New Zealand Diptera, Orthoptera, Hymenoptera; with descriptions of the species. Colonial Museum and Geological Survey of New Zealand, Wellington. x + 132 pp.
- 1901: Synopsis of the Diptera Brachycera of New Zealand. *Transactions and proceedings of the New Zealand Institute* 33: 1–95.
- Irwin, M.E. 1972: Diagnoses and habitat preferences of the immature stages of the three South African species of the *Xestomyza*-group (Diptera: Therevidae). *Annals of the Natal Museum* 21: 377–389.
- 1976: Morphology of the terminalia and known ovipositing behaviour of female Therevidae (Diptera: Asiloidea), with an account of correlated adaptations and comments on phylogenetic relationships. *Annals of the Natal Museum* 22: 913–935.
- Irwin, M.E.; Lyneborg, L. 1981: The genera of Nearctic Therevidae. *Illinois Natural History Survey bulletin* 32: 193–277.
- 1989: Family Therevidae. Pp. 353–358 in Evenhuis, N.L. (ed.), *Catalog of the Diptera of the Australasian and Oceanian regions*. Honolulu & Leiden. 1155 pp.
- Kröber, O. 1912: Die Thereviden der indo-australischen Region (Dipt.). *Entomologische Mitteilungen* 1: 116–125, 148–159, 183–189, 215–222, 242–256, 282–287.
- 1932: Die Thereviden Neuseelands (Dipt.). *Stettiner entomologische Zeitung* 93: 122–142.
- Lyneborg, L. 1972: A revision of the *Xestomyza*-group of Therevidae (Diptera). *Annals of the Natal Museum* 21: 297–376.
- 1976: A revision of the therevine stiletto-flies (Diptera: Therevidae) of the Ethiopian Region. *Bulletin of the British Museum (Natural History), entomology*, 33(3): 189–346.
- Macquart, J. 1848: Diptères exotiques nouveaux ou peu connus. Suite du 2^m supplément. *Mémoires de la Société des Sciences, de l'Agriculture et des Arts de Lille* 1847(2): 161–237.
- 1850: Diptères exotiques nouveaux ou peu connus. 4^e supplément. *Mémoires de la Société des Sciences, de l'Agriculture et des Arts de Lille* 1849: 309–479.
- Mann, J.S. 1928: Revisional notes on Australian Therevidae. Part 1. *The Australian zoologist* 5: 151–194.
- 1929: Revisional notes on Australian Therevidae. Part 2. *The Australian zoologist* 6: 17–49.
- 1933: Revisional notes on Australian Therevidae. Part 3. *The Australian zoologist* 7: 325–344.
- Schiner, I.R. 1868: Diptera. In: *Reise der österreichischen Fregatte Novara um die Erde Zool. Theil, 2. Band*. Wien. vi + 388 pp.
- Walker, F. 1856: Diptera. Part V, pp. 415–474, in *Insecta Saundersiana*. London. 474 pp.
- Watt, J.C. 1979: Abbreviations for entomological collections. *New Zealand journal of zoology* 6: 519–520.
- Webb, D.W.; Irwin, M.E. 1988: The genera *Ataenogera* and *Phycus* in the New World (Diptera: Therevidae: Phycinae). *Proceedings of the Entomological Society of Washington* 91: 35–50.

ILLUSTRATIONS

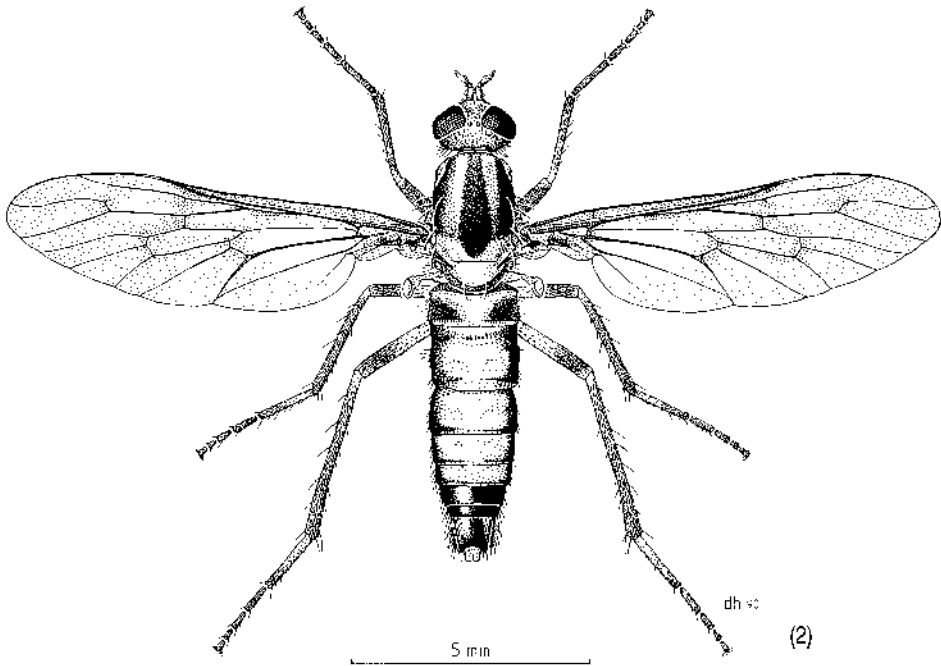
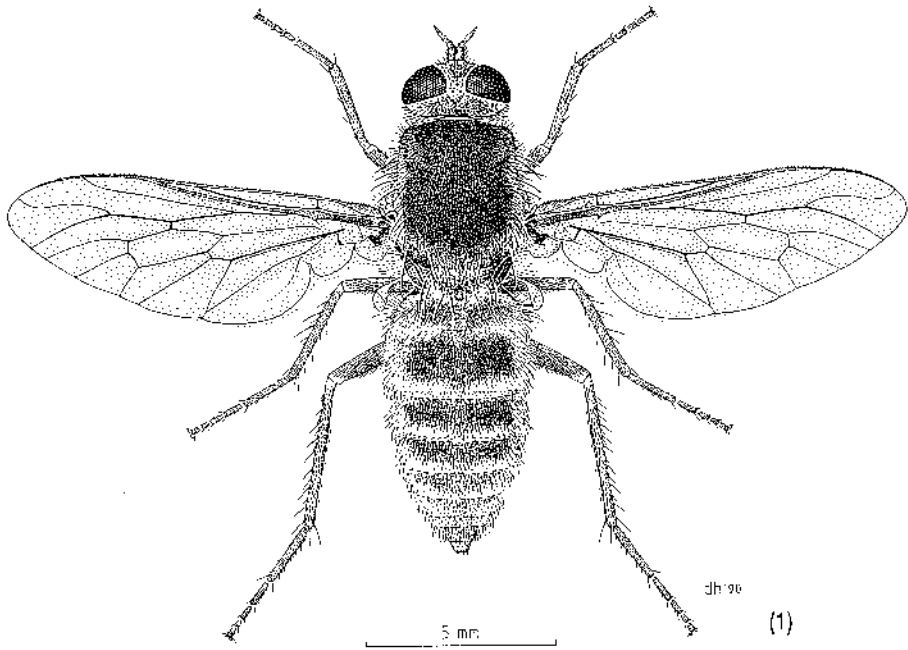
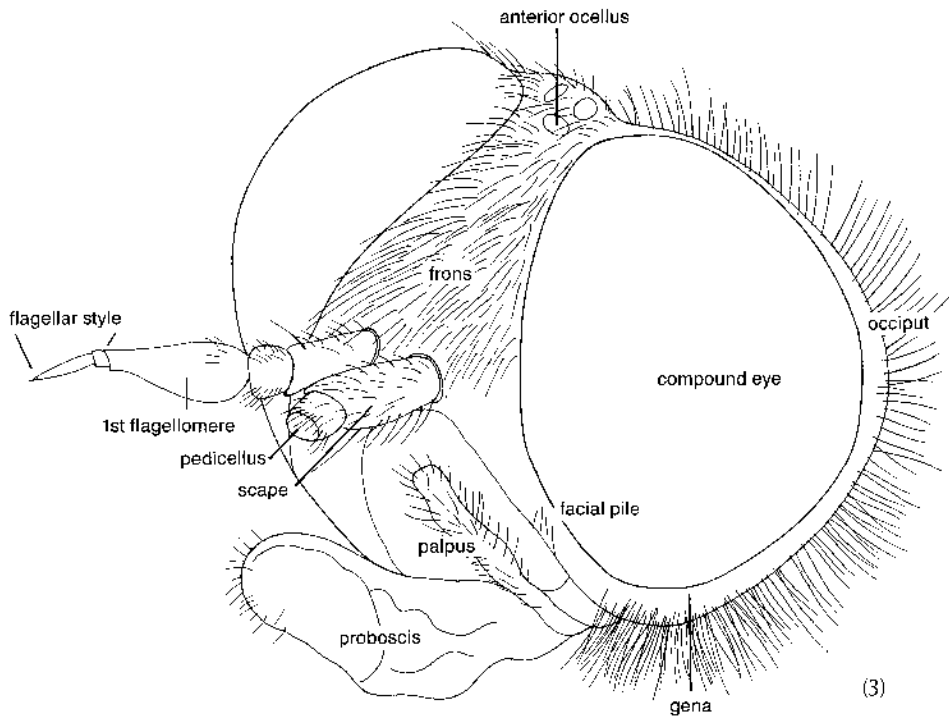
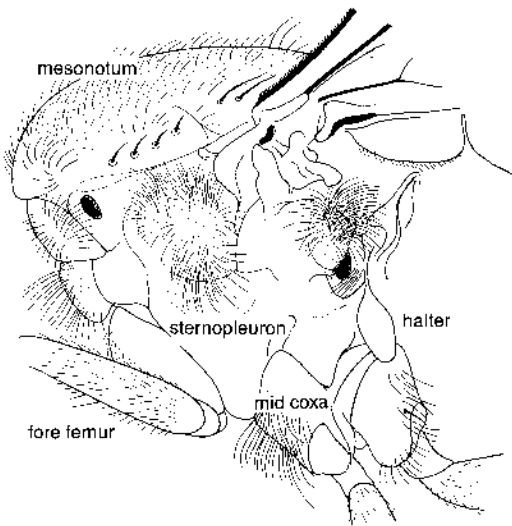

Fig. 1, 2 Dorsal habitus, male, *Anabarhynchus innotatus* and *Ectinorhynchus castaneus*. Artist: Des Helmore.



(3)



(4)

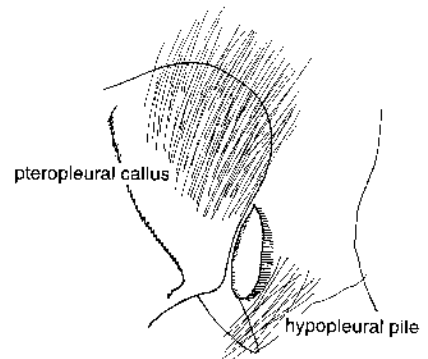

(5)

Fig. 3-12 Morphology of adult Therevidae, based on *Anabarhynchus innotatus*: (3) head, male, frontolateral; (4) thorax, lateral; (5) hypopleuron and pteropleural callus; (continued on p. 77)

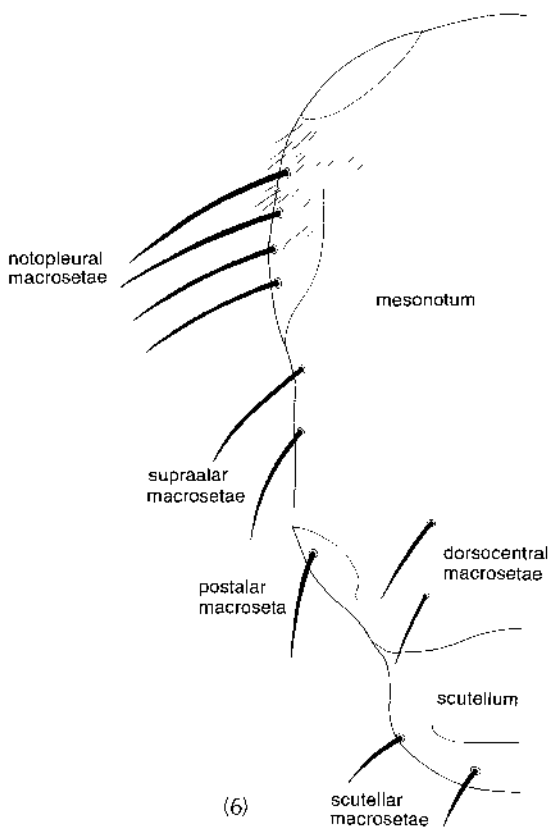

(6)

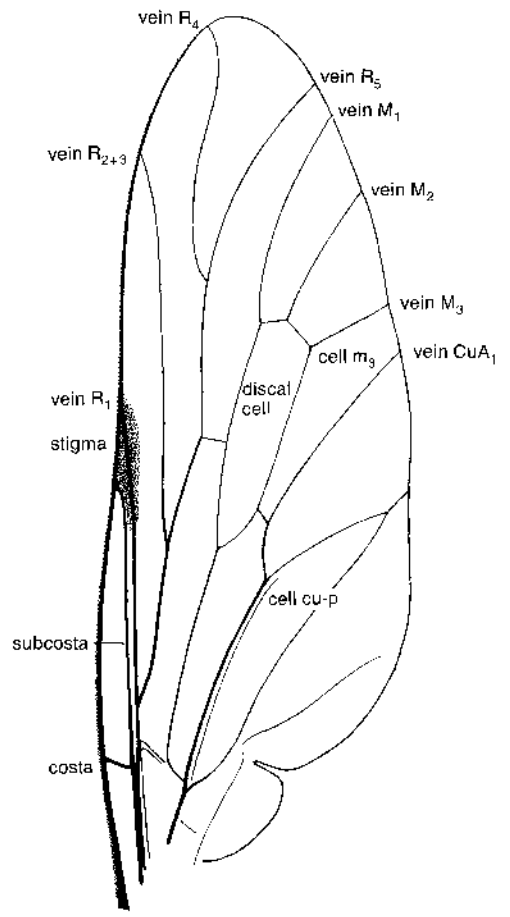

(7)

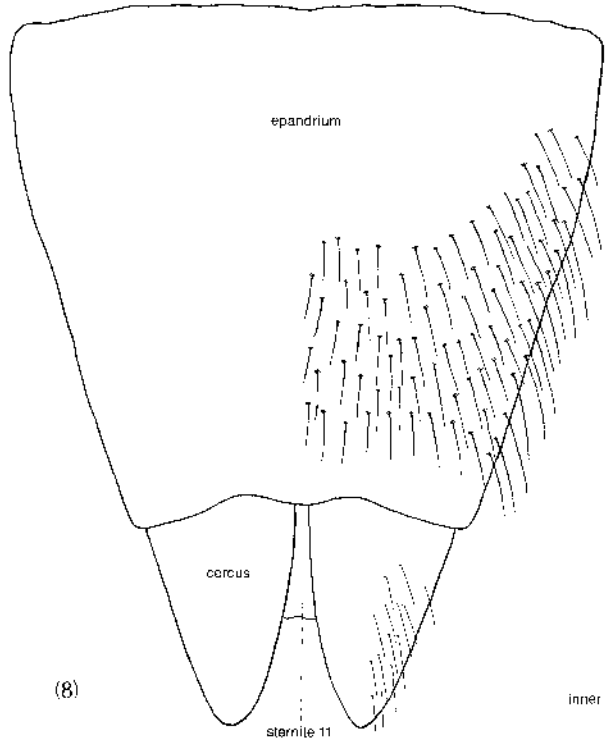

(8)

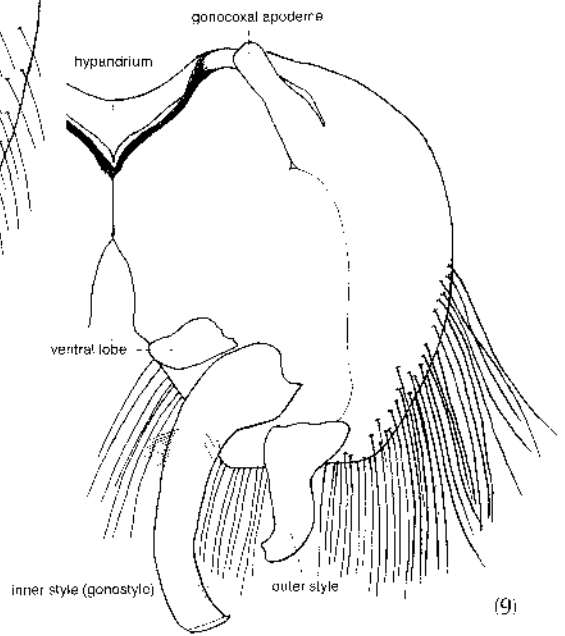

(9)

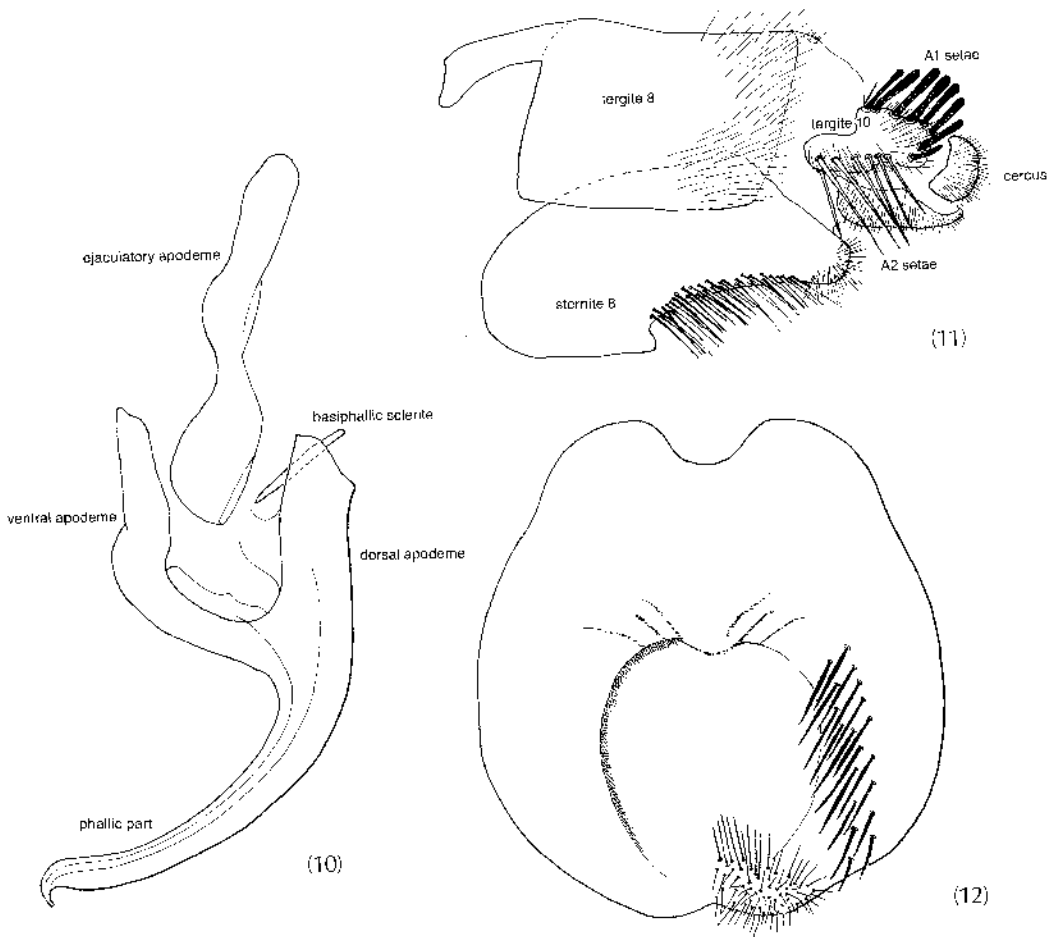

(cont.) (6) thoracic macrosetae; (7) wing venation; (8) epandrium and cerci, male, dorsal; (9) right gonocoxite with appendages, male, dorsal; (10) aedeagus, male, lateral; (11) genitalia, female, lateral; (12) sternite 8, female, ventral (i.e., face view).

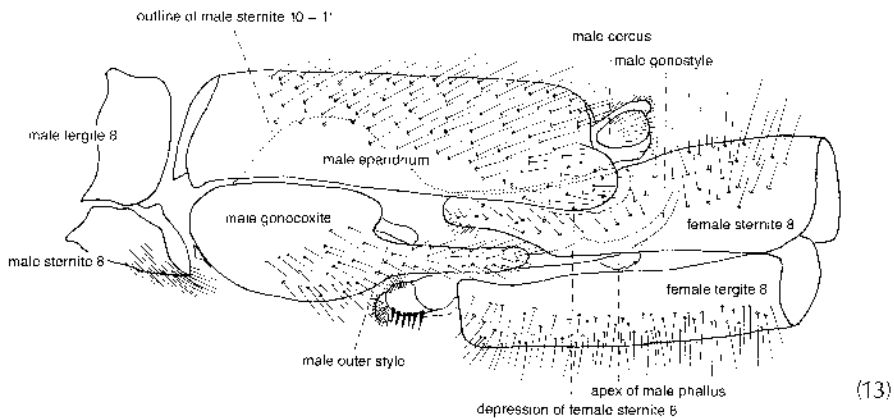

Fig. 13 *Ectinorhynchus cupreus*, coupling, lateral.

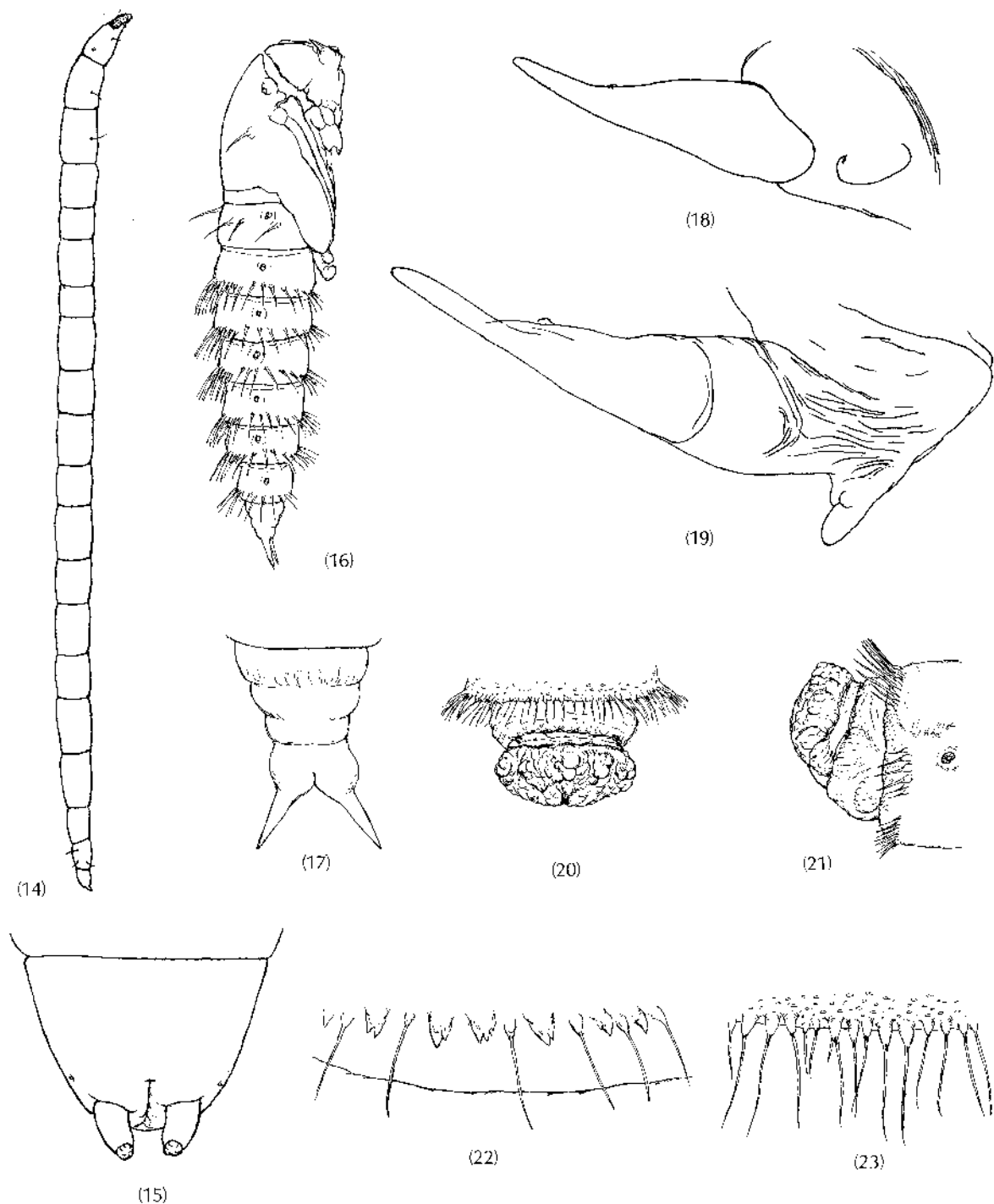

Fig. 14–23 Morphology of larvae and pupae of Therevidae: (14, 15) larva, *Anabarhynchus* sp., lateral, and terminal segment, ventral; (16, 17) pupa, *A. maori*, lateral, and terminal segment, ventral; (18, 19) right antennal sheath, pupa, *A. maori* and *Megathereva albopilosa*, anterior; (20, 21) terminal segments, pupa, *M. albopilosa*, ventral and lateral; (22, 23) posterior margin of 3rd abdominal segment, dorsal, pupa, *A. maori* and *M. albopilosa*.

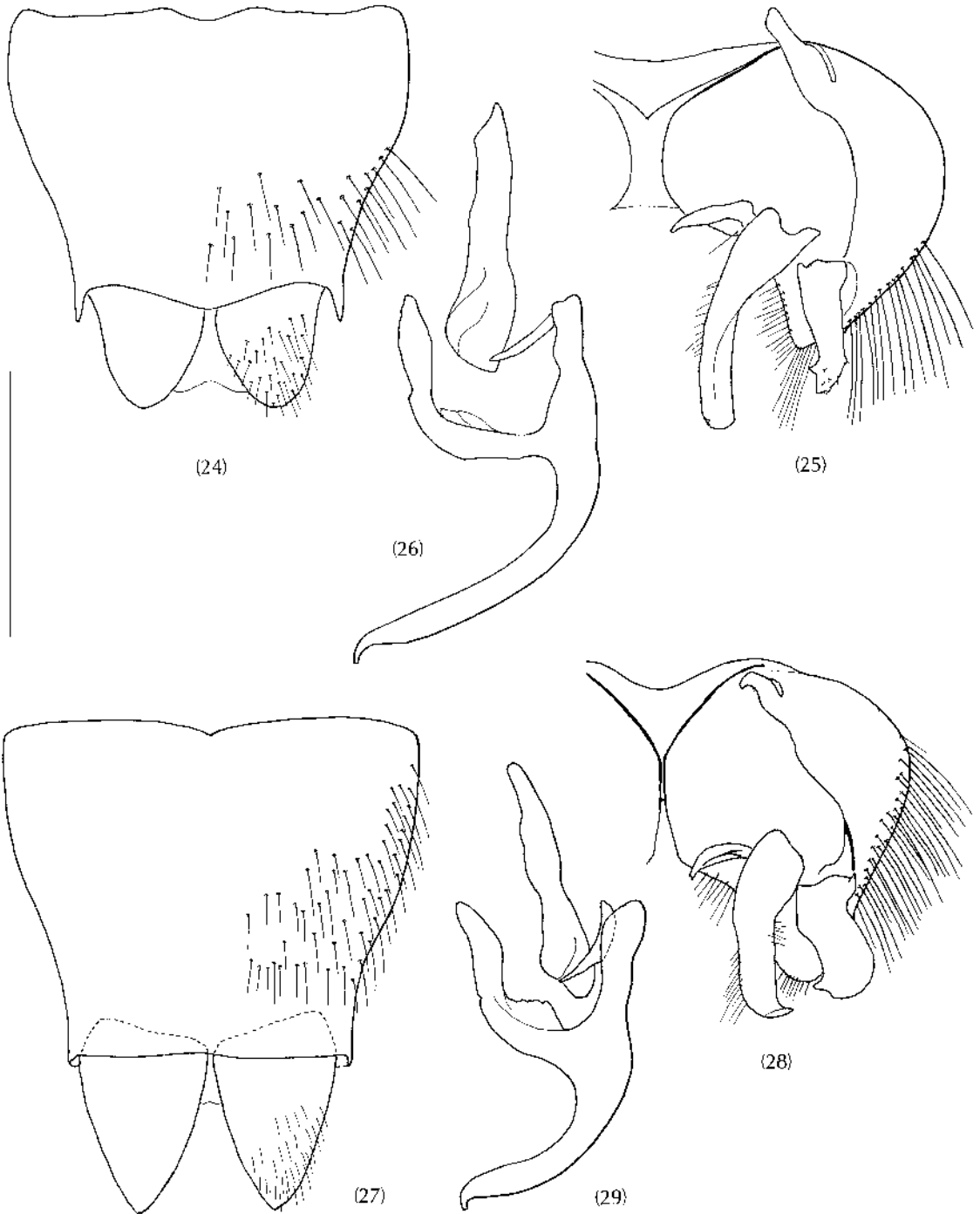

Fig. 24–203 Male genitalia, *Anabarhynchus* species. Scale line: 0.5 mm.
 24–26 *A. acuminatus*: epandrium and cerci, dorsal; gonocoxite with
 appendages, dorsal; aedeagus, lateral. 27–29 *A. albipennis*, ditto.

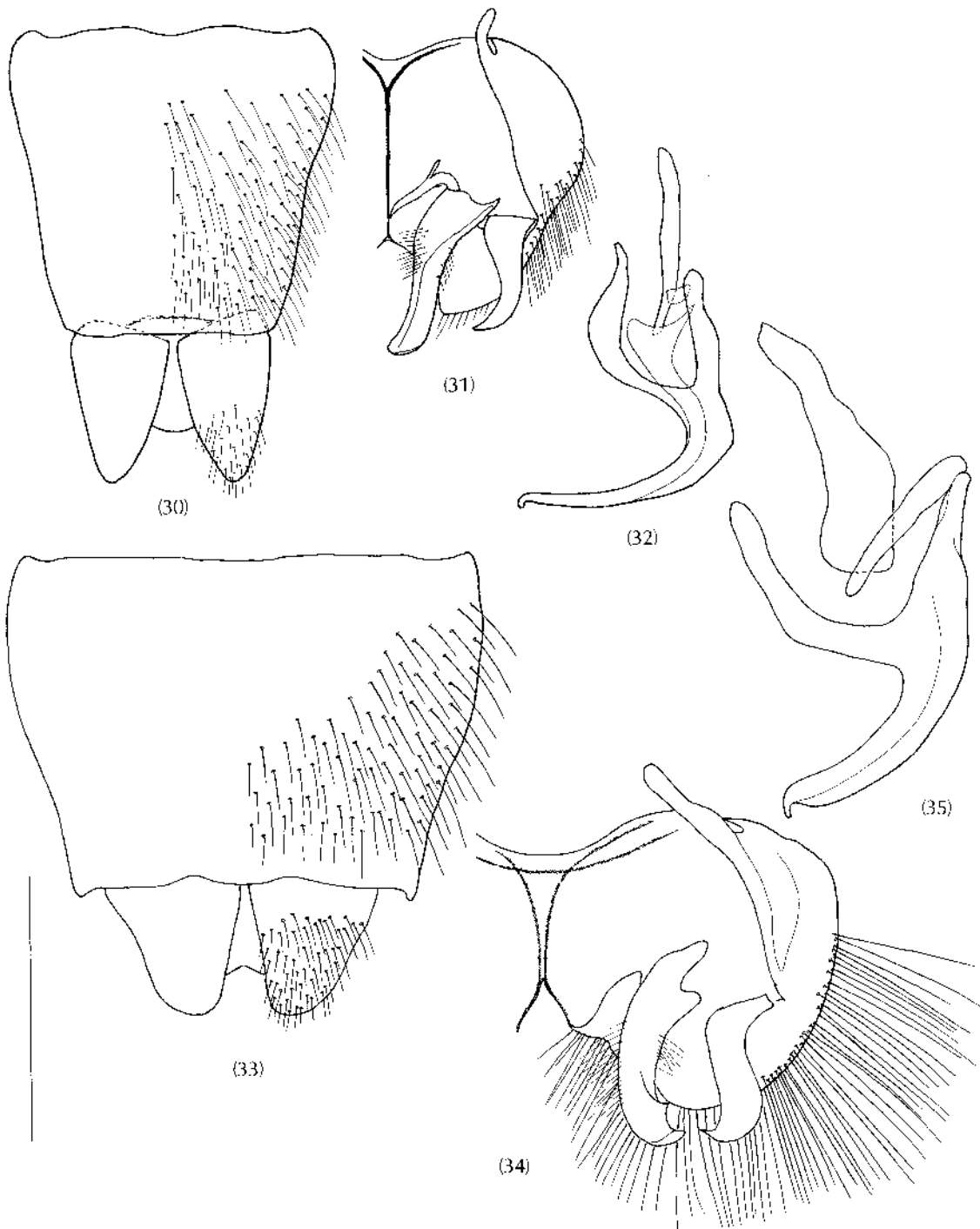

Fig. 30–32 *A. arenarius*: (30) epandrium; (31) gonocoxite; (32) aedeagus.
 Fig. 33–35 *A. atratus*: (33) epandrium; (34) gonocoxite; (35) aedeagus.

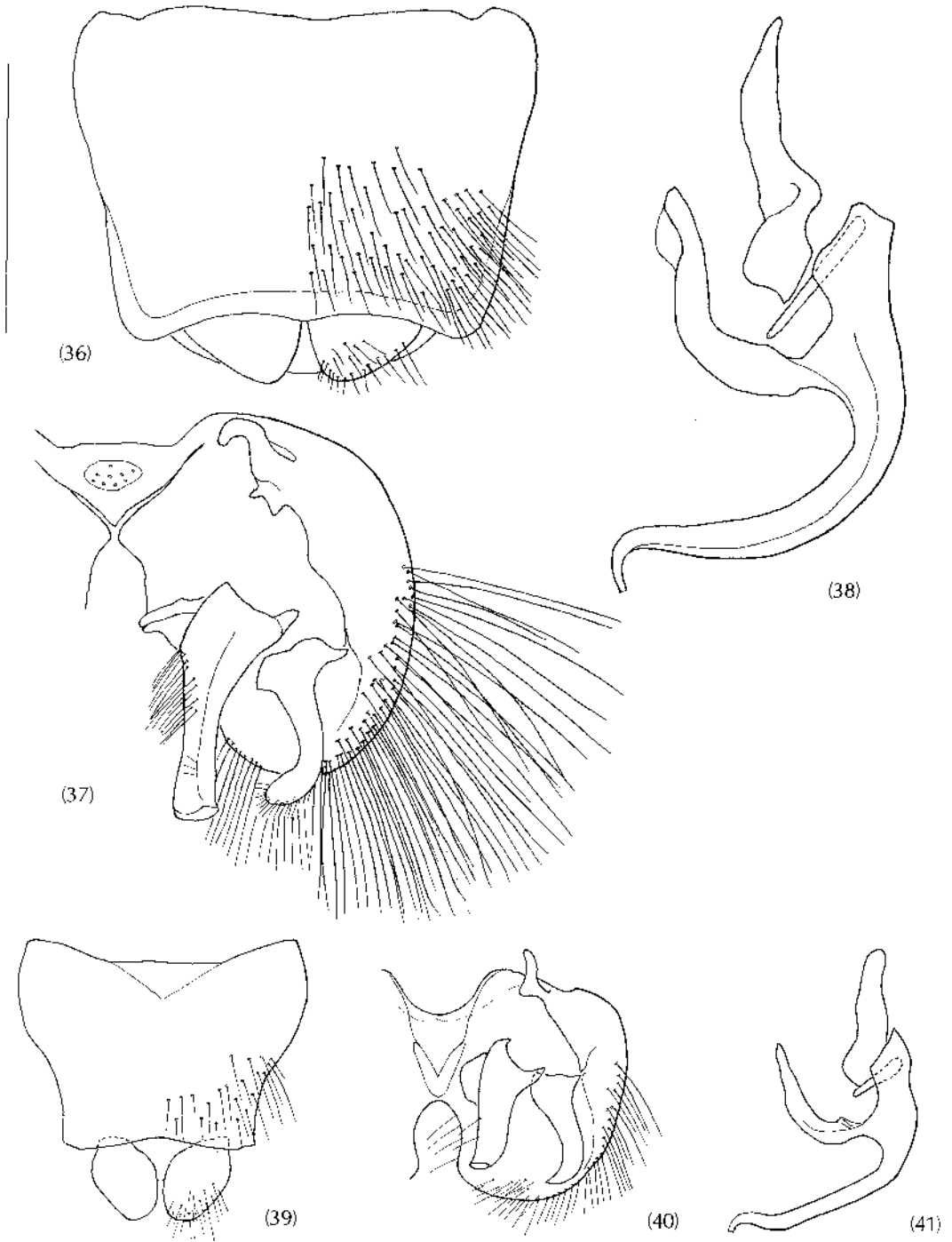

Fig. 36-38 *A. atripes*: (36) epandrium; (37) gonocoxite; (38) aedeagus.
 Fig. 39-41 *A. brevicornis*: (39) epandrium; (40) gonocoxite; (41) aedeagus.

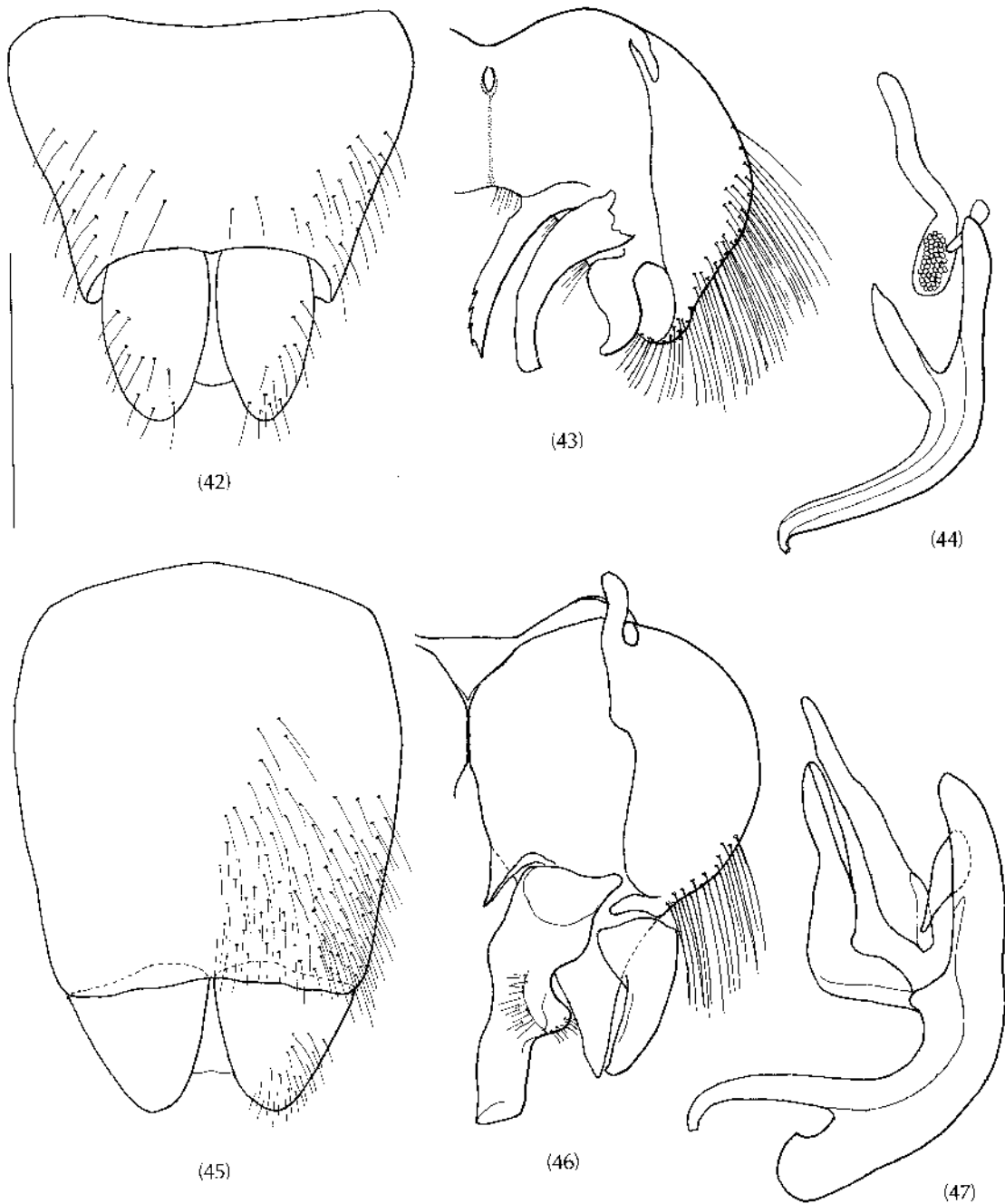

Fig. 42-44 *A. aureosericeus*: (42) epandrium; (43) gonocoxite; (44) aedeagus.
 Fig. 45-47 *A. brunneris*: (45) epandrium; (46) gonocoxite; (47) aedeagus.

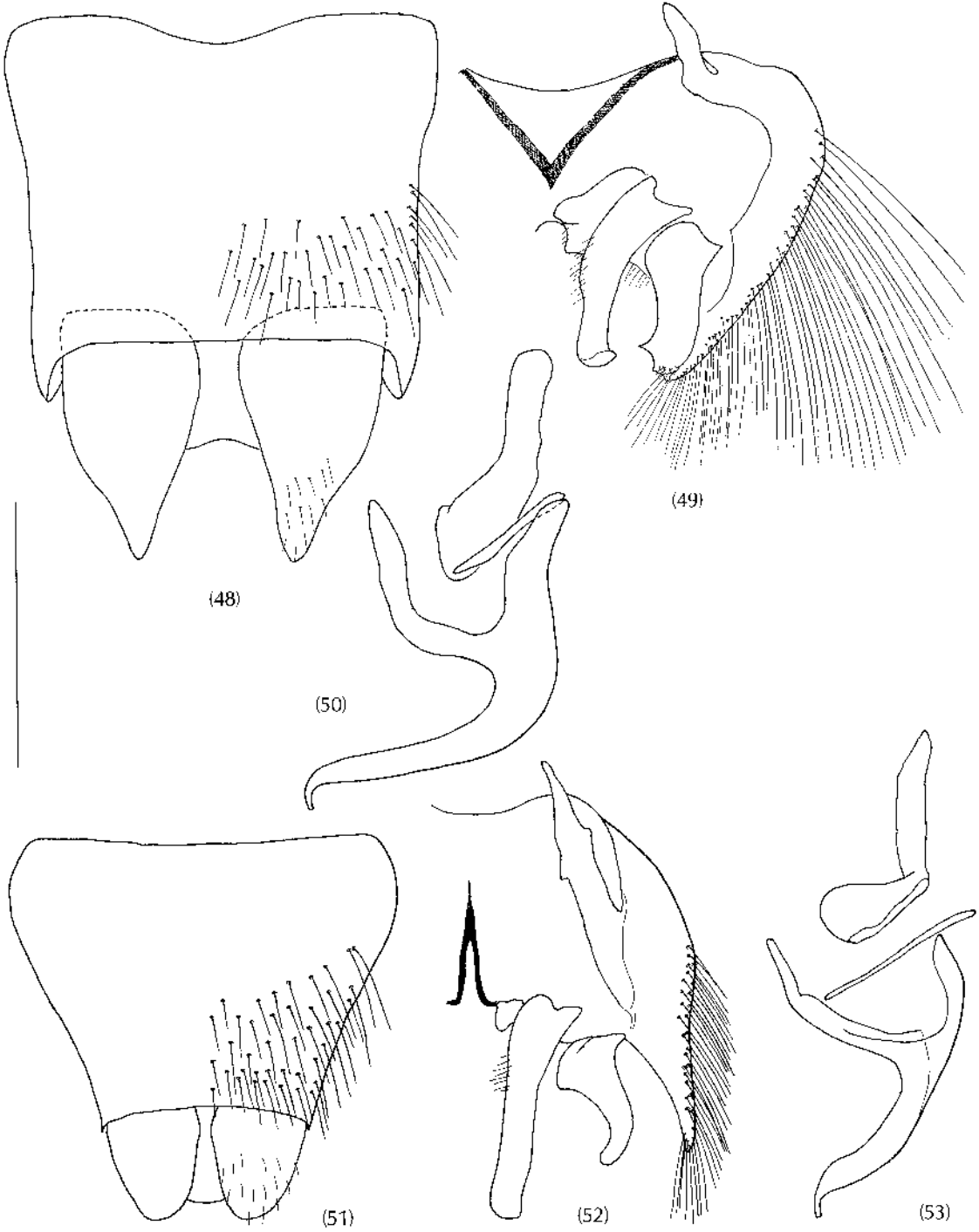

Fig. 48-50 *A. caesius*: (48) epandrium; (49) gonocoxite; (50) aedeagus.
Fig. 51-53 *A. completus*: (51) epandrium; (52) gonocoxite; (53) aedeagus.

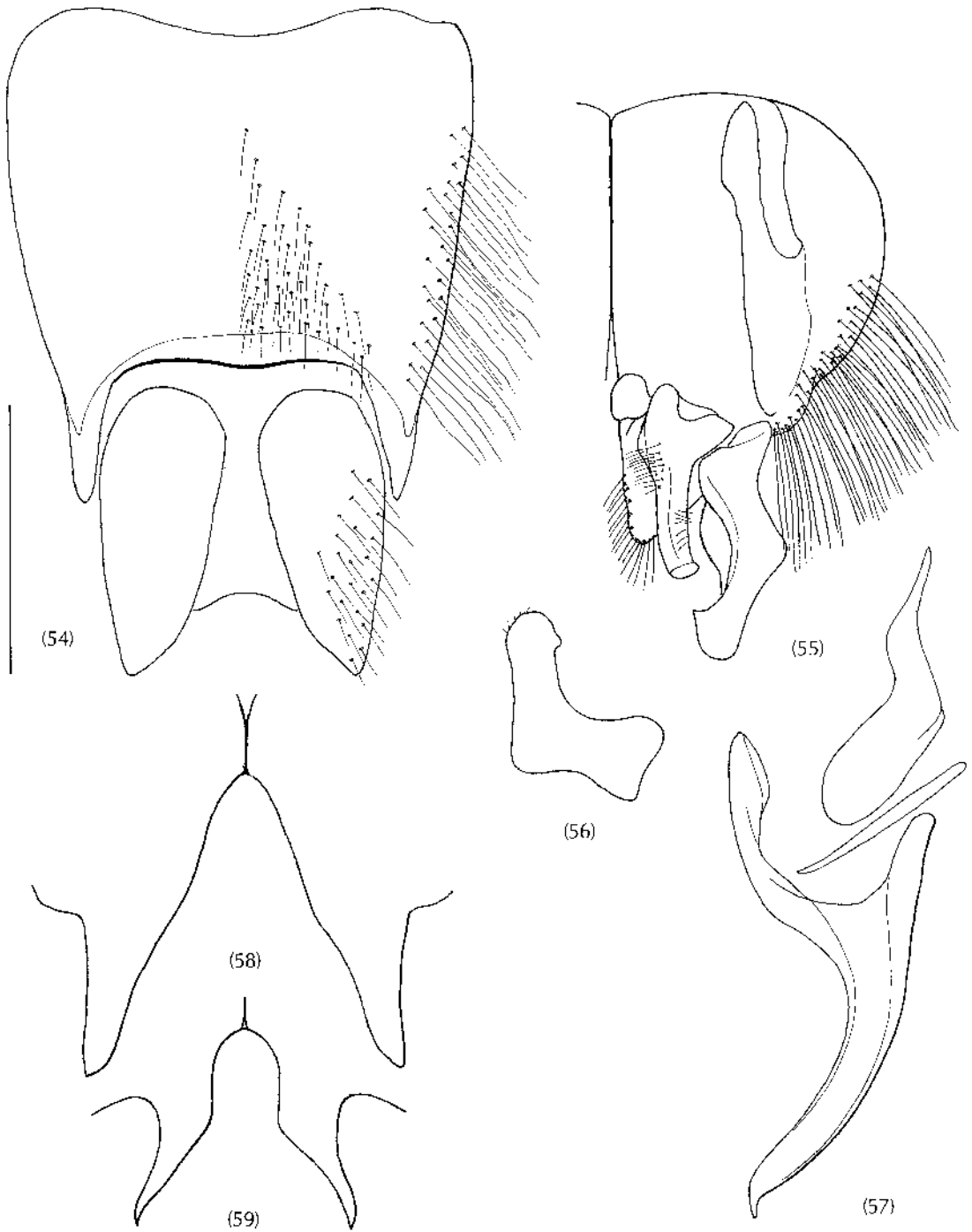

Fig. 54–57 *A. curvistylus*: (54) epandrium; (55) gonocoxite; (56) outer style; (57) aedeagus.
 Fig. 58, 59 Ventral gonocoxal spines, *Anabarhynchus bruninervis* and *A. spiniger*.

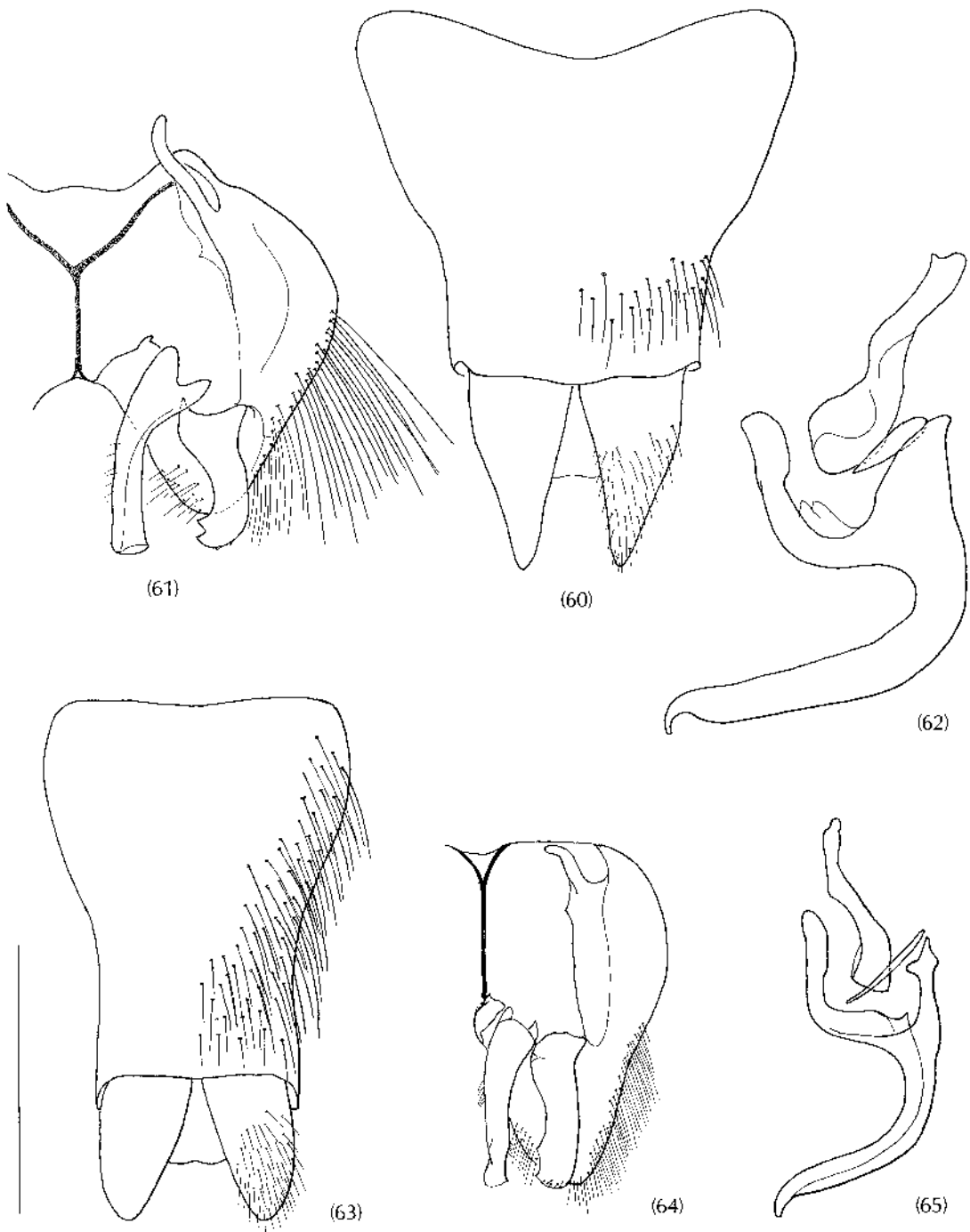

Fig. 60–62 *A. diversicolor*: (60) epandrium; (61) gonocoxite; (62) aedeagus.
 Fig. 63–65 *A. exiguus*: (63) epandrium; (64) gonocoxite; (65) aedeagus.

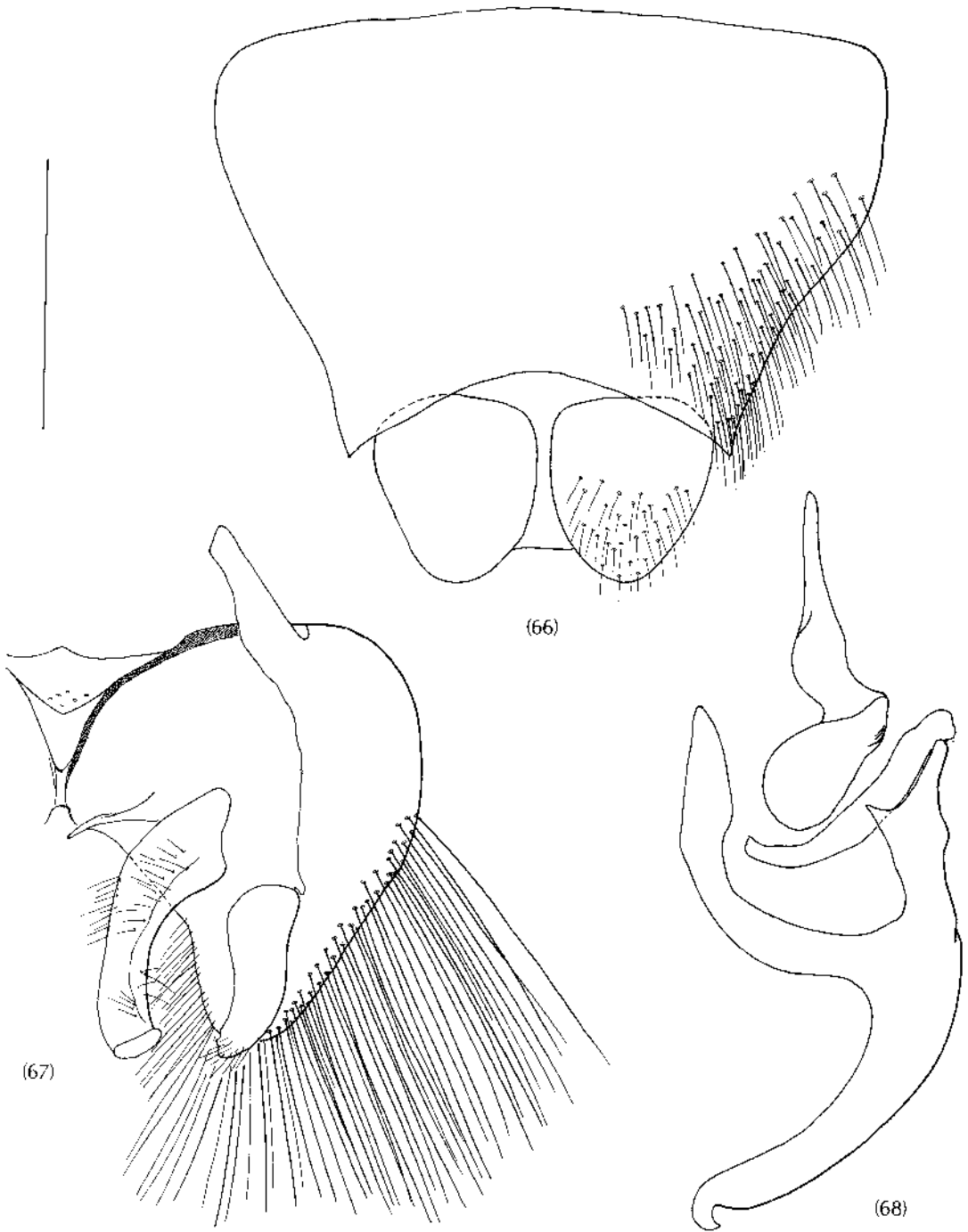

Fig. 66-68 *A. dugdalei*: (66) epandrium; (67) gonocoxite; (68) aedeagus.

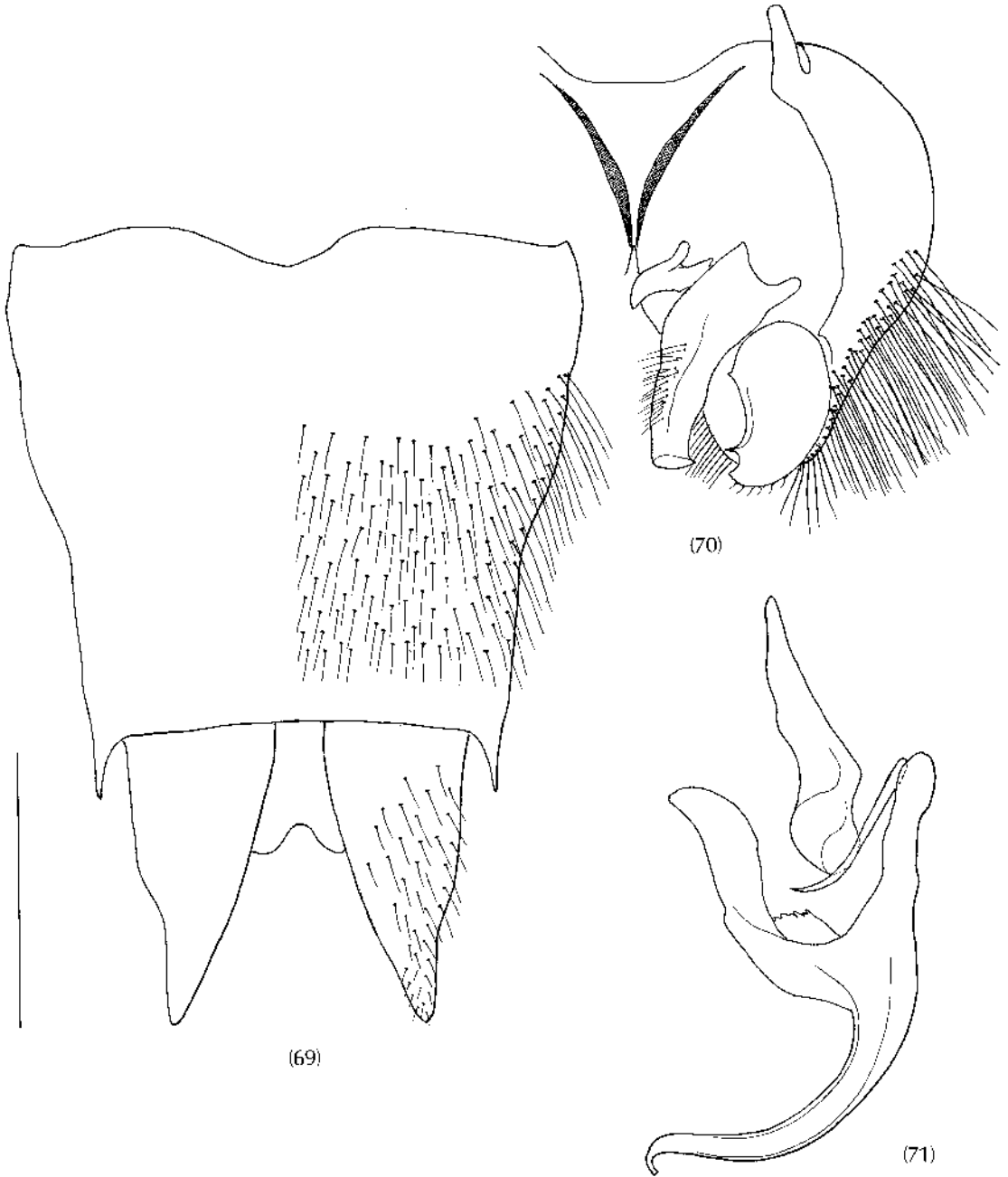
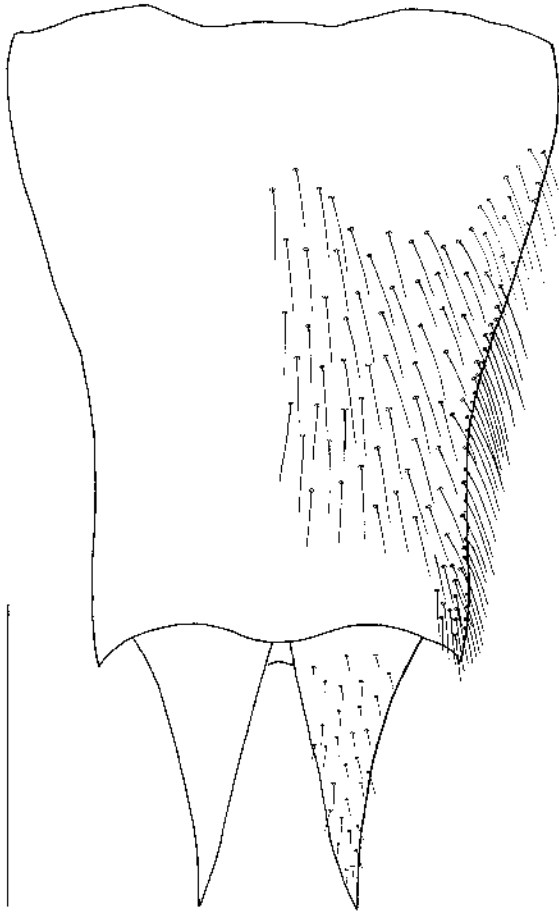
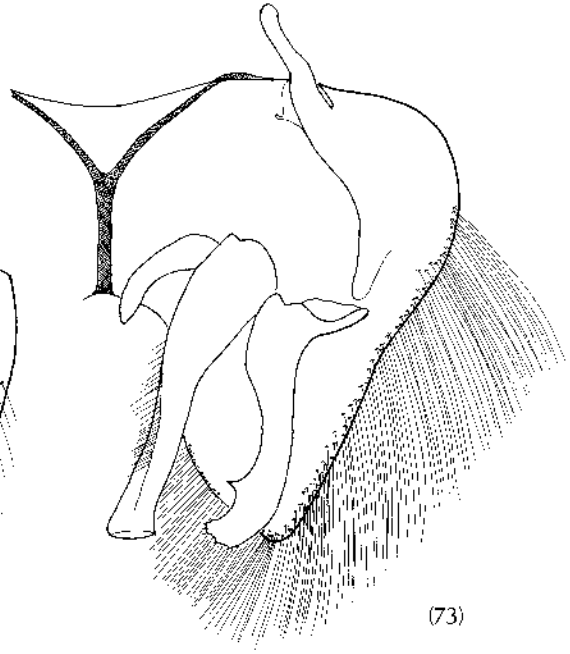

Fig. 69-71 *A. dysmachiiformis*: (69) epandrium; (70) gonocoxite; (71) aedeagus.



(72)



(73)

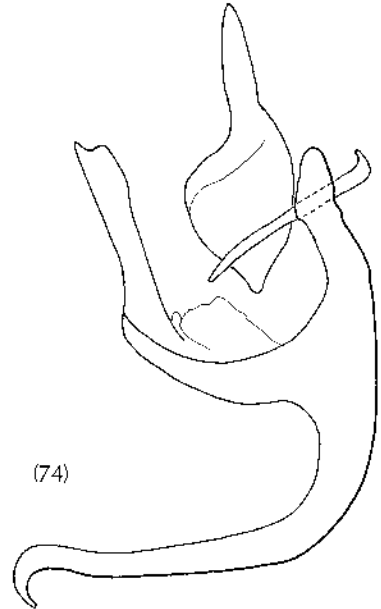

(74)

Fig. 72-74 *A. embersoni*: (72) epandrium; (73) gonocoxite; (74) aedeagus.

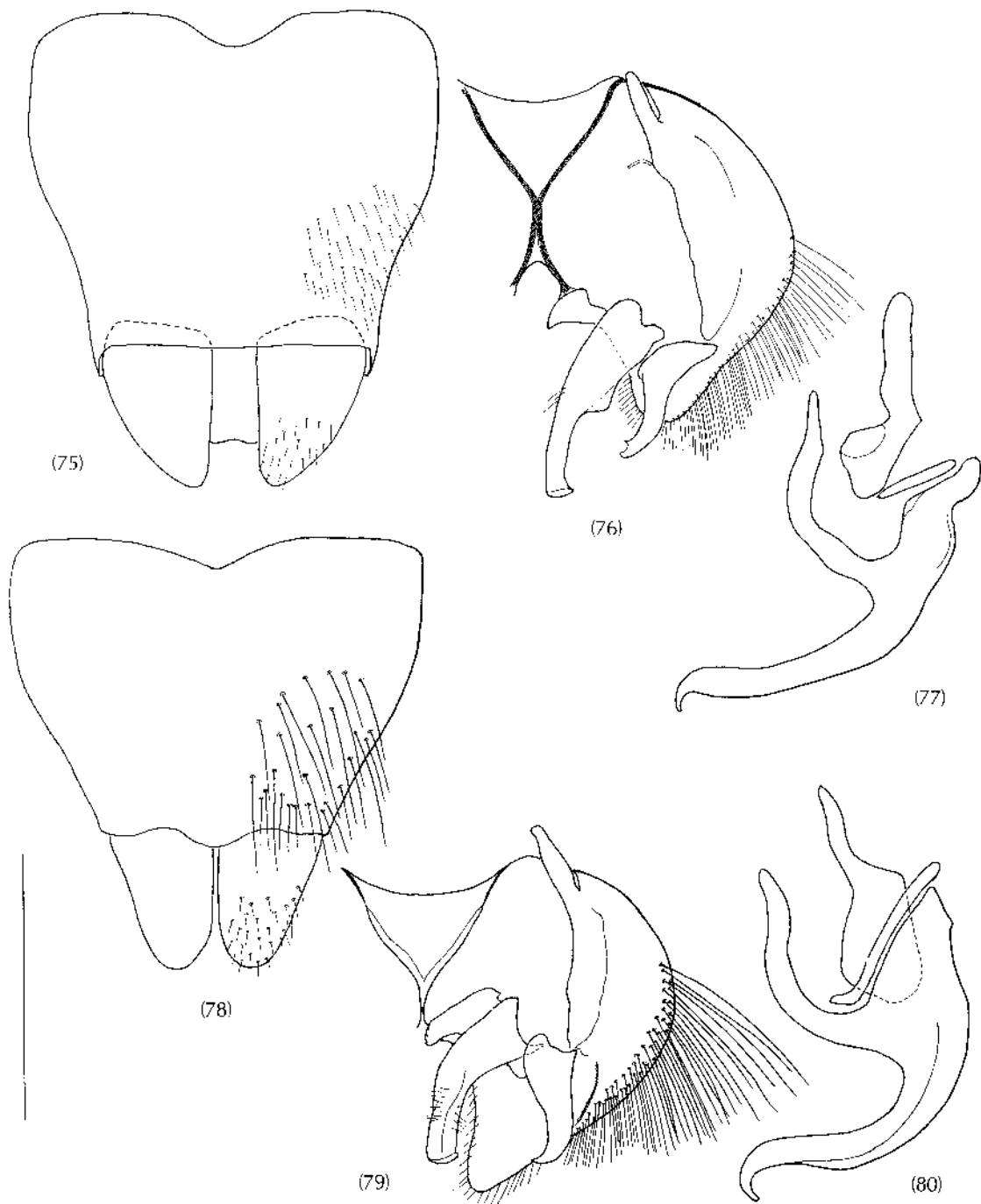

Fig. 75-77 *A. farinosus*: (75) epandrium; (76) gonocoxite; (77) aedeagus.
Fig. 78-80 *A. femoralis*: (78) epandrium; (79) gonocoxite; (80) aedeagus.

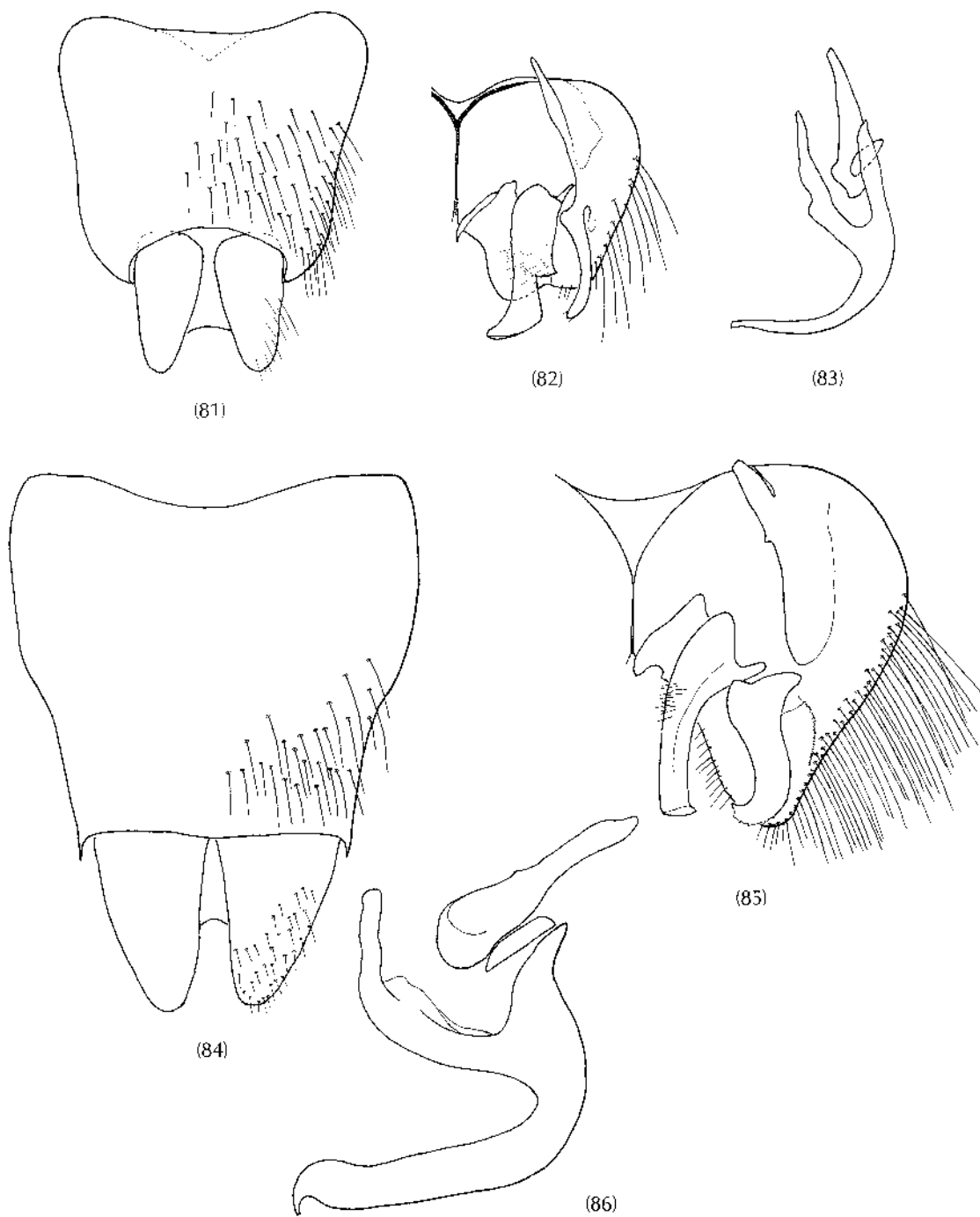

Fig. 81-83 *A. fenwicki*: (81) epandrium; (82) gonocoxite; (83) aedeagus.
Fig. 84-86 *A. flaviventris*: (84) epandrium; (85) gonocoxite; (86) aedeagus.

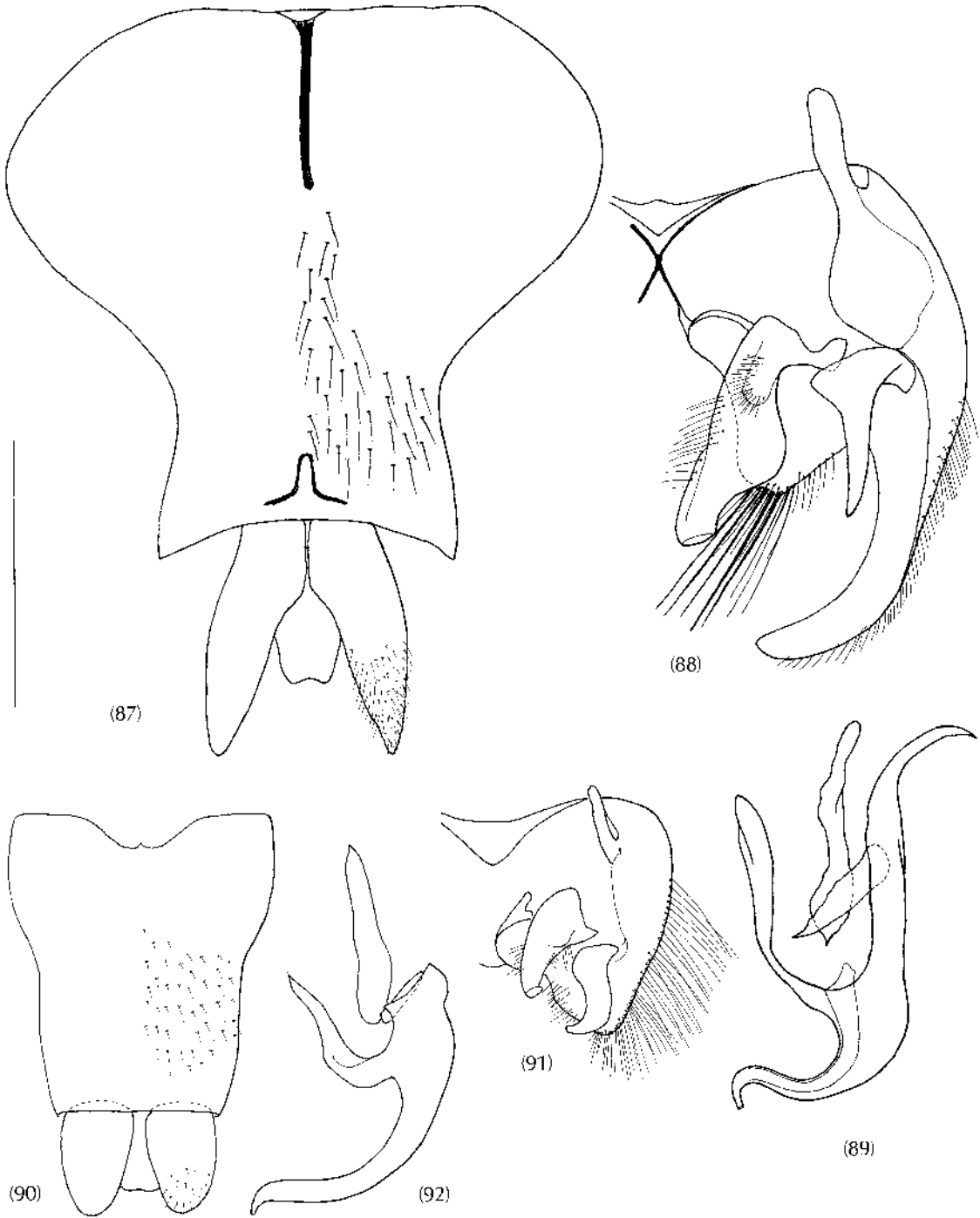

Fig. 87-89 *A. fluviatilis*: (87) epandrium; (88) gonocoxite; (89) aedeagus.
 Fig. 90-92 *A. fuscofemoratus*: (90) epandrium; (91) gonocoxite; (92) aedeagus.

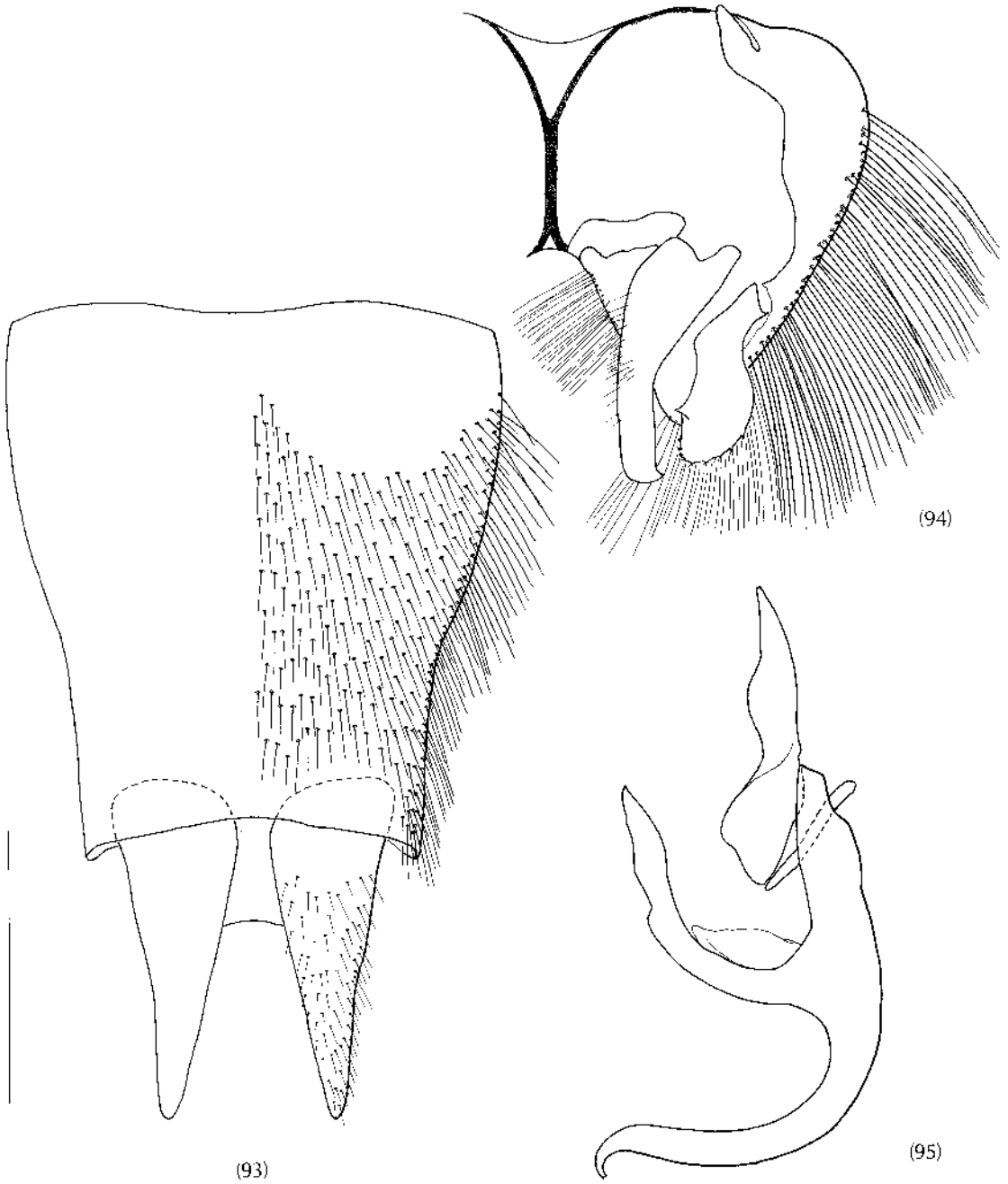

Fig. 93–95 *A. gibbsi*: (93) epandrium; (94) gonocoxite; (95) aedeagus.

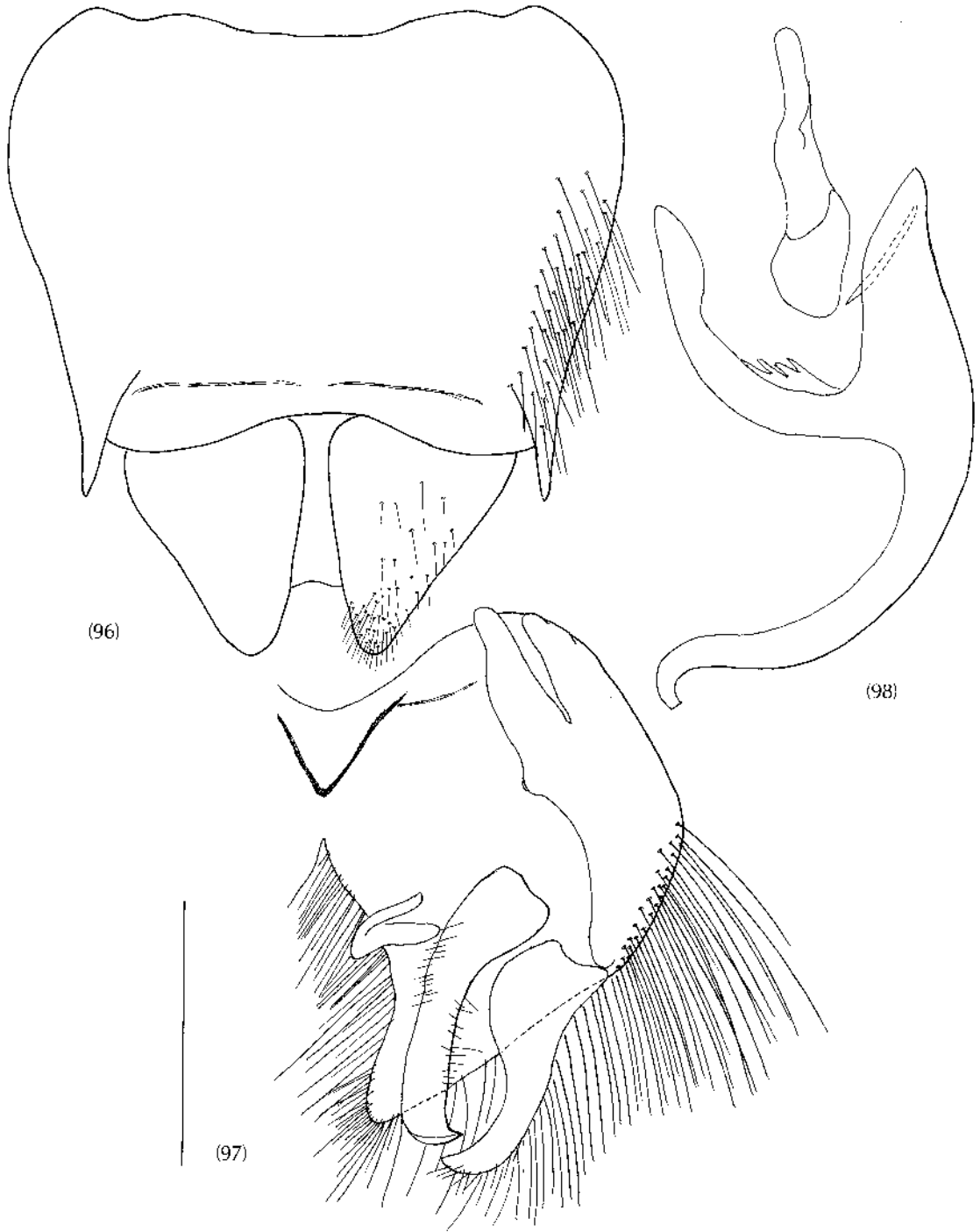

Fig. 96–98 *A. grossus*: (96) epandrium; (97) gonocoxite; (98) aedeagus.

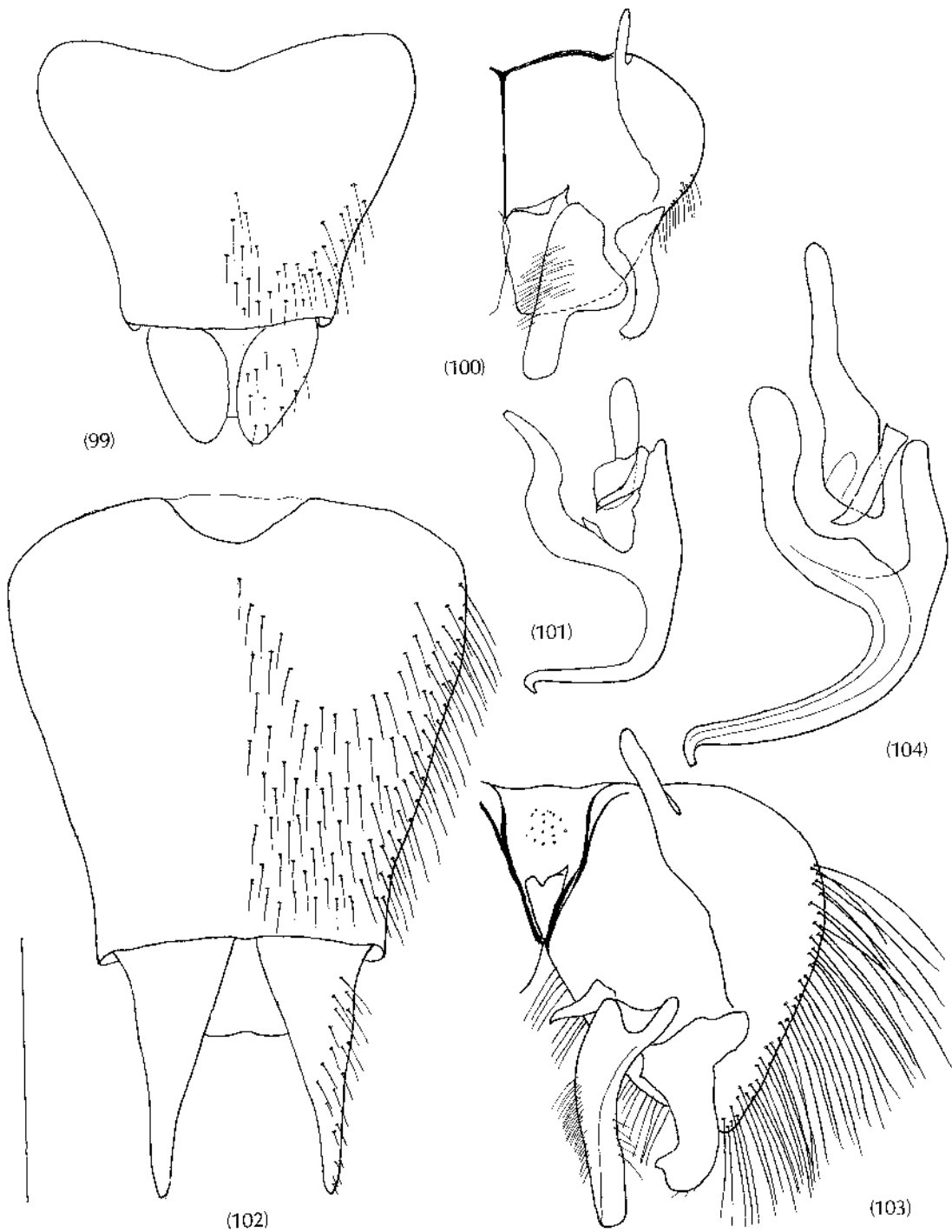
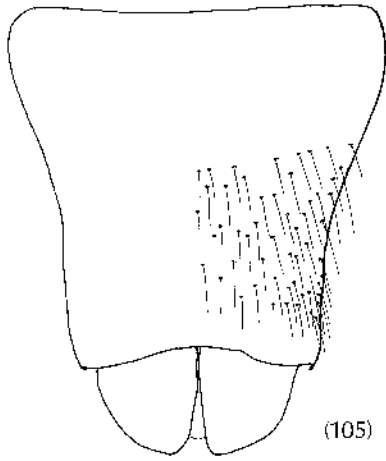
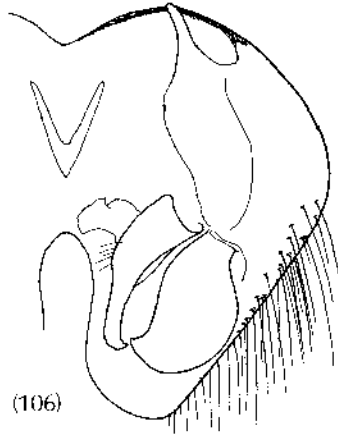

Fig. 99–101 *A. harrisi*: (99) epandrium; (100) gonocoxite; (101) aedeagus.
Fig. 102–104 *A. hayakawai*: (102) epandrium; (103) gonocoxite; (104) aedeagus.



(105)



(106)

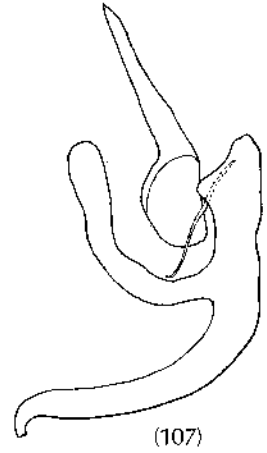

(107)

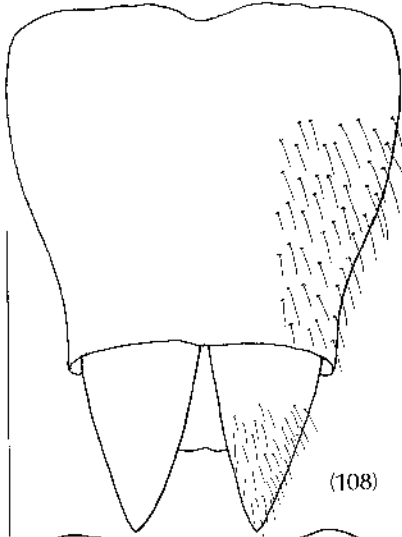

(108)

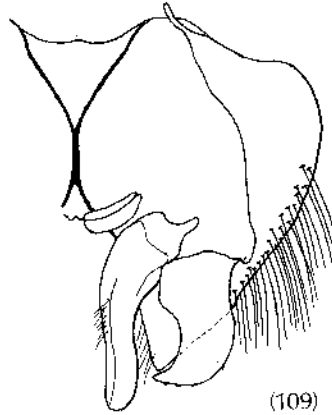

(109)

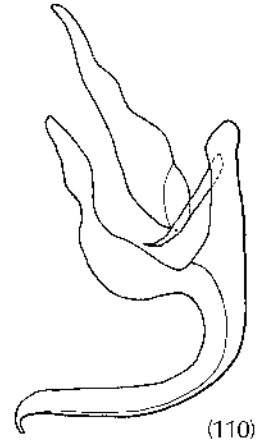

(110)

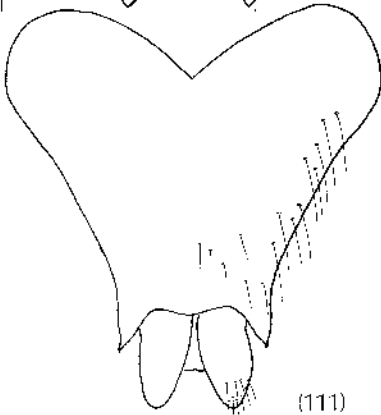

(111)

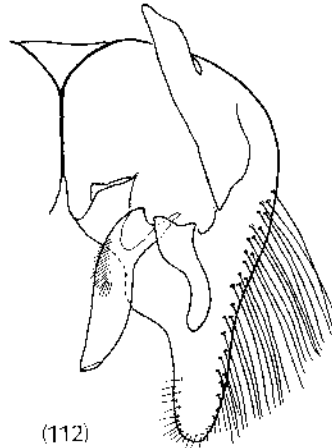

(112)

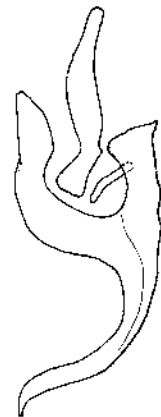

(113)

Fig. 105–107 *A. hudsoni*: (105) epandrium; (106) gonocoxite; (107) aedeagus.
Fig. 108–110 *A. huttoni*: (108) epandrium; (109) gonocoxite; (110) aedeagus.
Fig. 111–113 *A. limbatinervis*: (111) epandrium; (112) gonocoxite; (113) aedeagus.

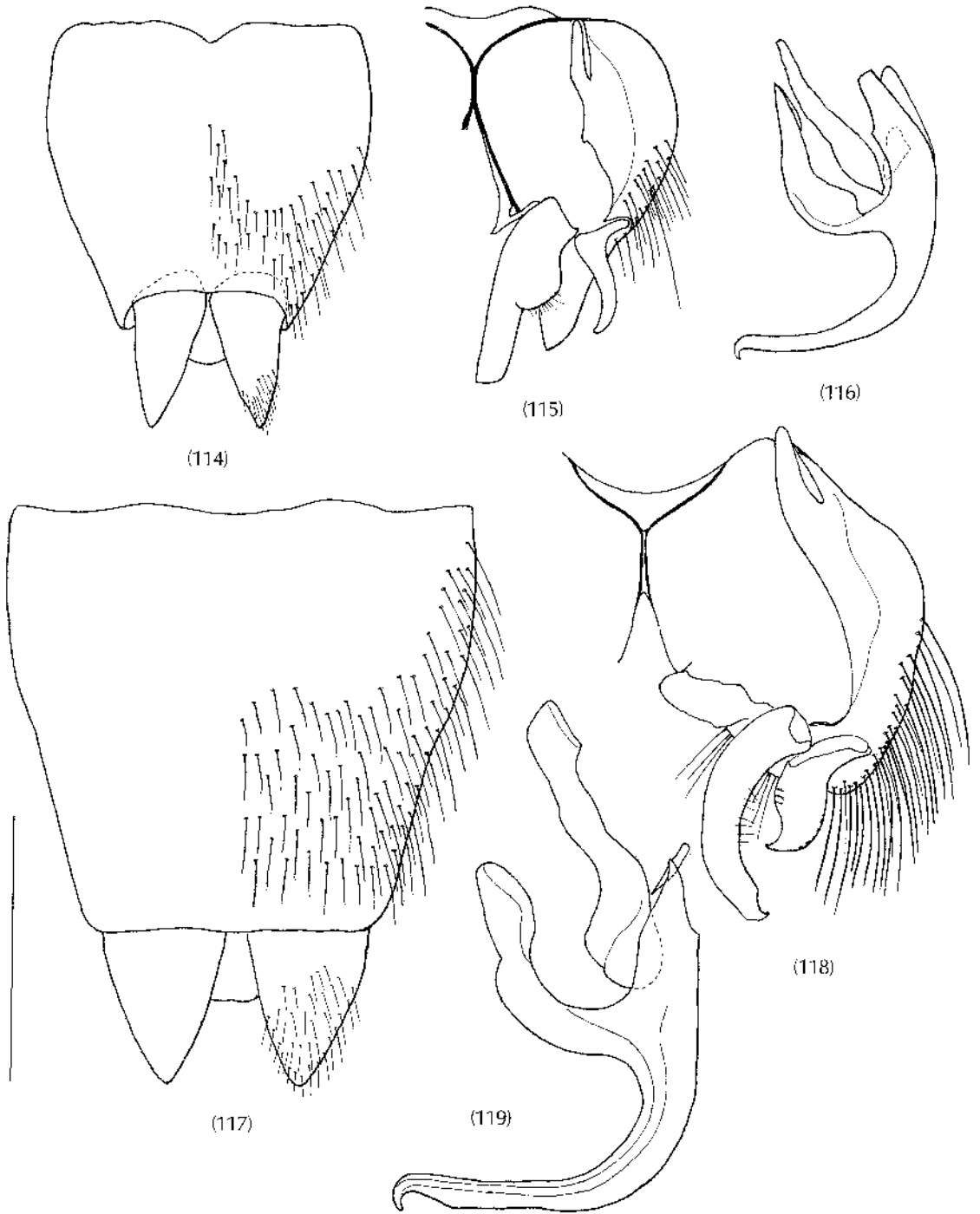

Fig. 114–116 *A. indistinctus*: (114) epandrium; (115) gonocoxite; (116) aedeagus.
 Fig. 117–119 *A. innotatus*: (117) epandrium; (118) gonocoxite; (119) aedeagus.

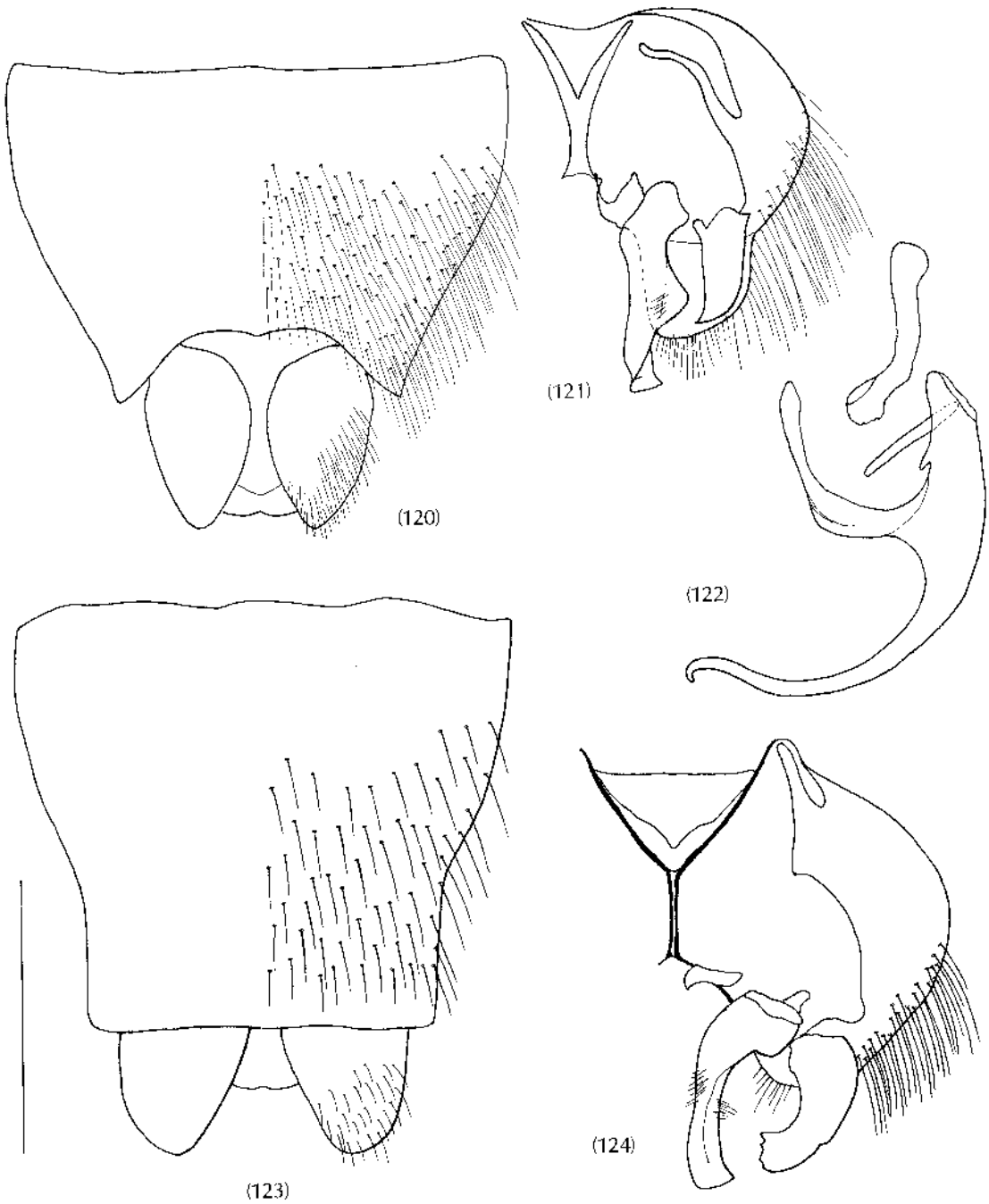

Fig. 120–122 *A. laterepilosus*: (120) epandrium; (121) gonocoxite; (122) aedeagus.
 Fig. 123, 124 *A. latus*: (123) epandrium; (124) gonocoxite.

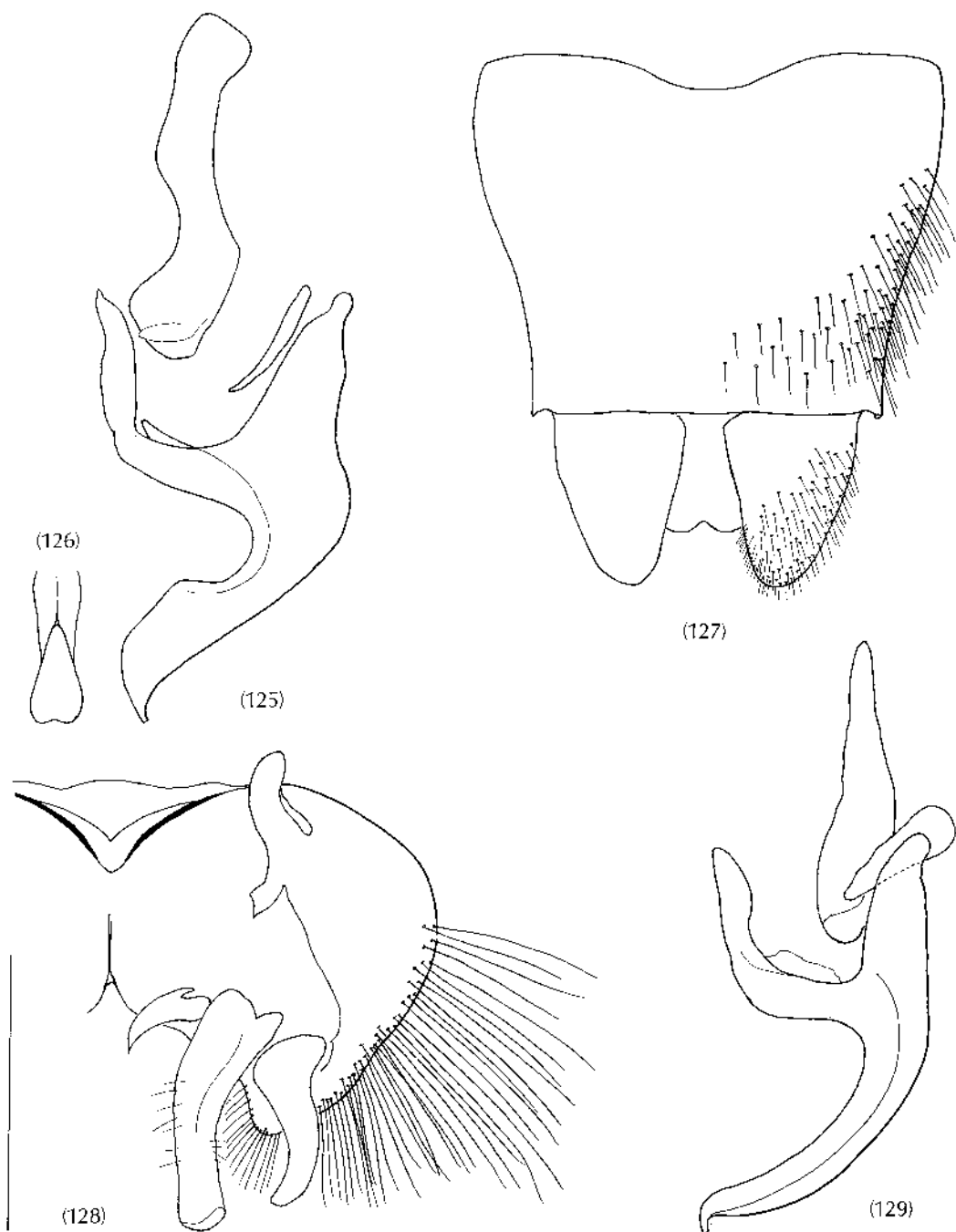

Fig. 125, 126 *A. latus*: (125) aedeagus; (126) apex of aedeagus.
 Fig. 127-129 *A. longepilosus*: (127) epandrium; (128) gonocoxite; (129) aedeagus.

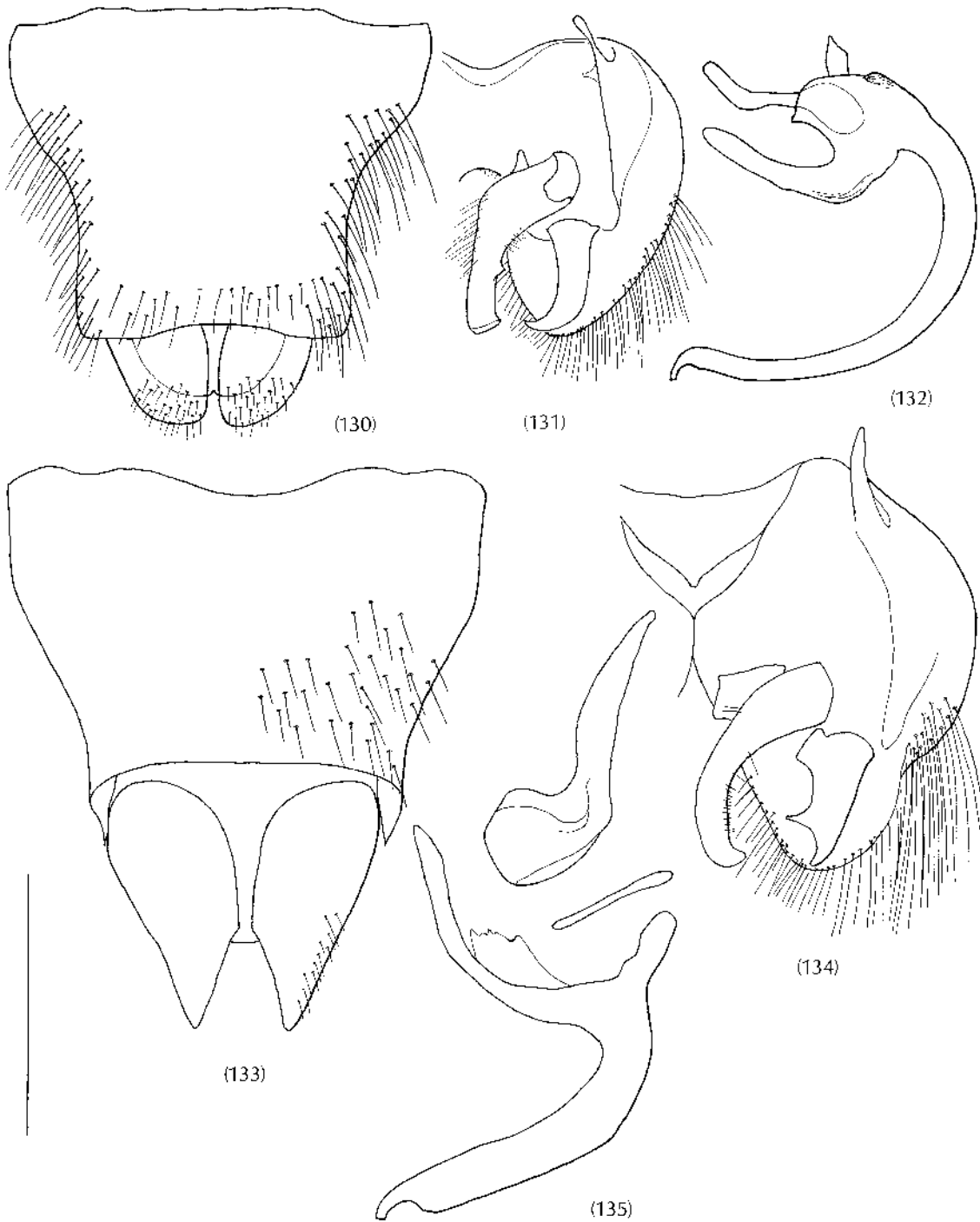

Fig. 130–132 *A. longipennis*: (130) epandrium; (131) gonocoxite; (132) aedeagus.
 Fig. 133–135 *A. maclartanei*: (133) epandrium; (134) gonocoxite; (135) aedeagus.

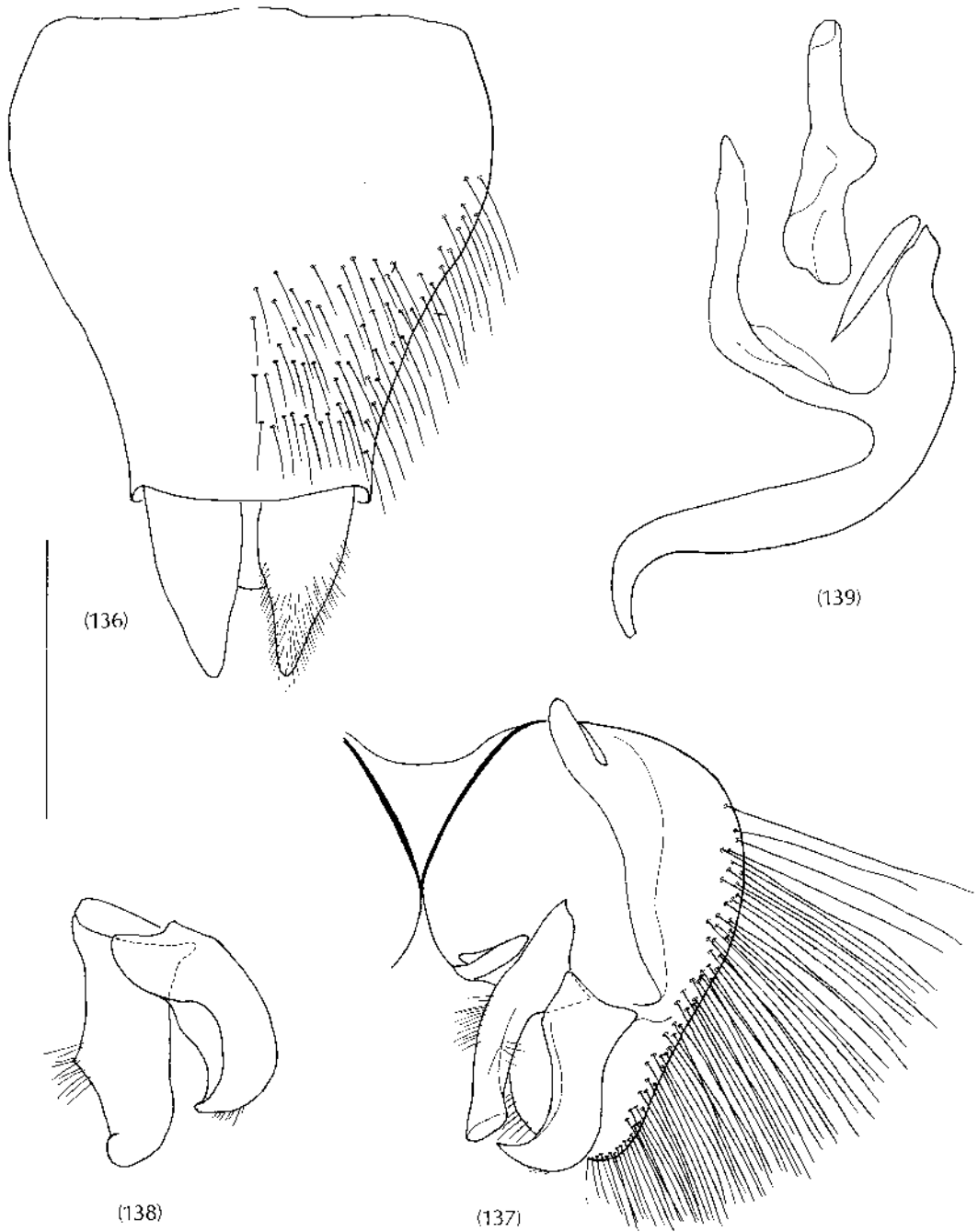

Fig. 136-139 *A. major*: (136) epandrium; (137) gonocoxite; (138) outer and inner styles, lateral; (139) aedeagus.

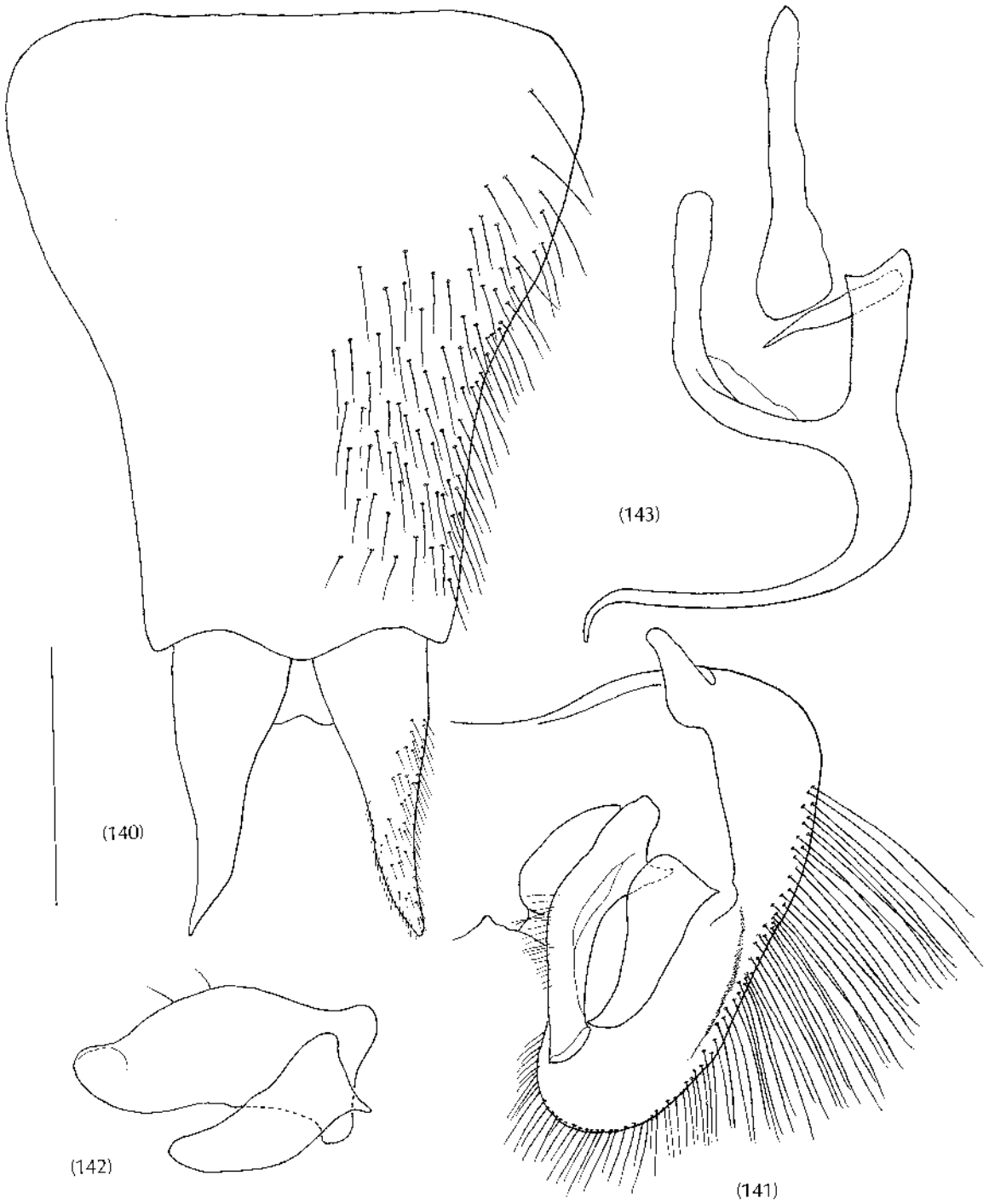

Fig. 140-143 *A. megalopyge*: (140) epandrium; (141) gonocoxite; (142) outer and inner styles, lateral; (143) aedeagus.

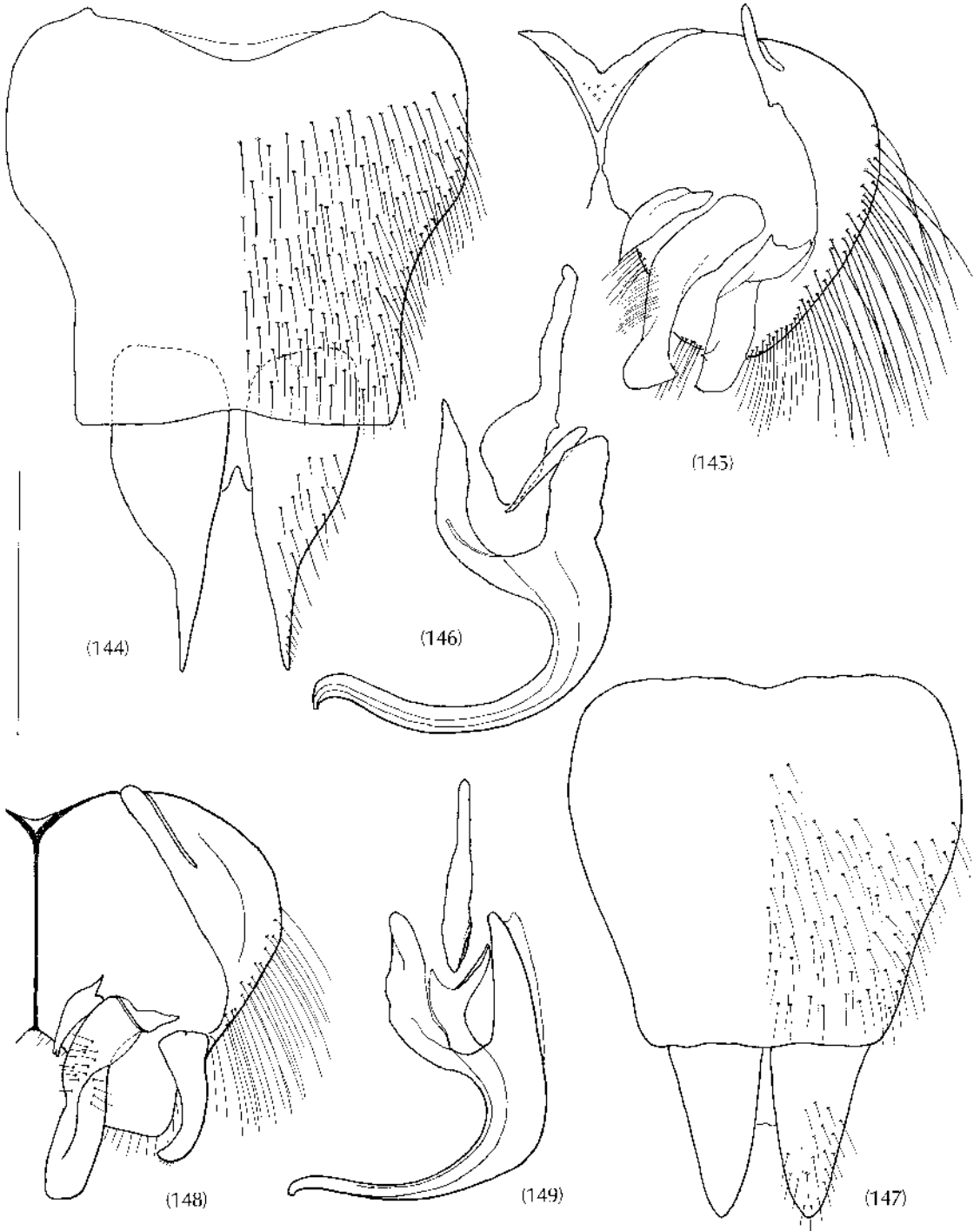

Fig. 144–146 *A. maori*: (144) epandrium; (145) gonocoxite; (146) aedeagus.
Fig. 147–149 *A. monticola*: (147) epandrium; (148) gonocoxite; (149) aedeagus.

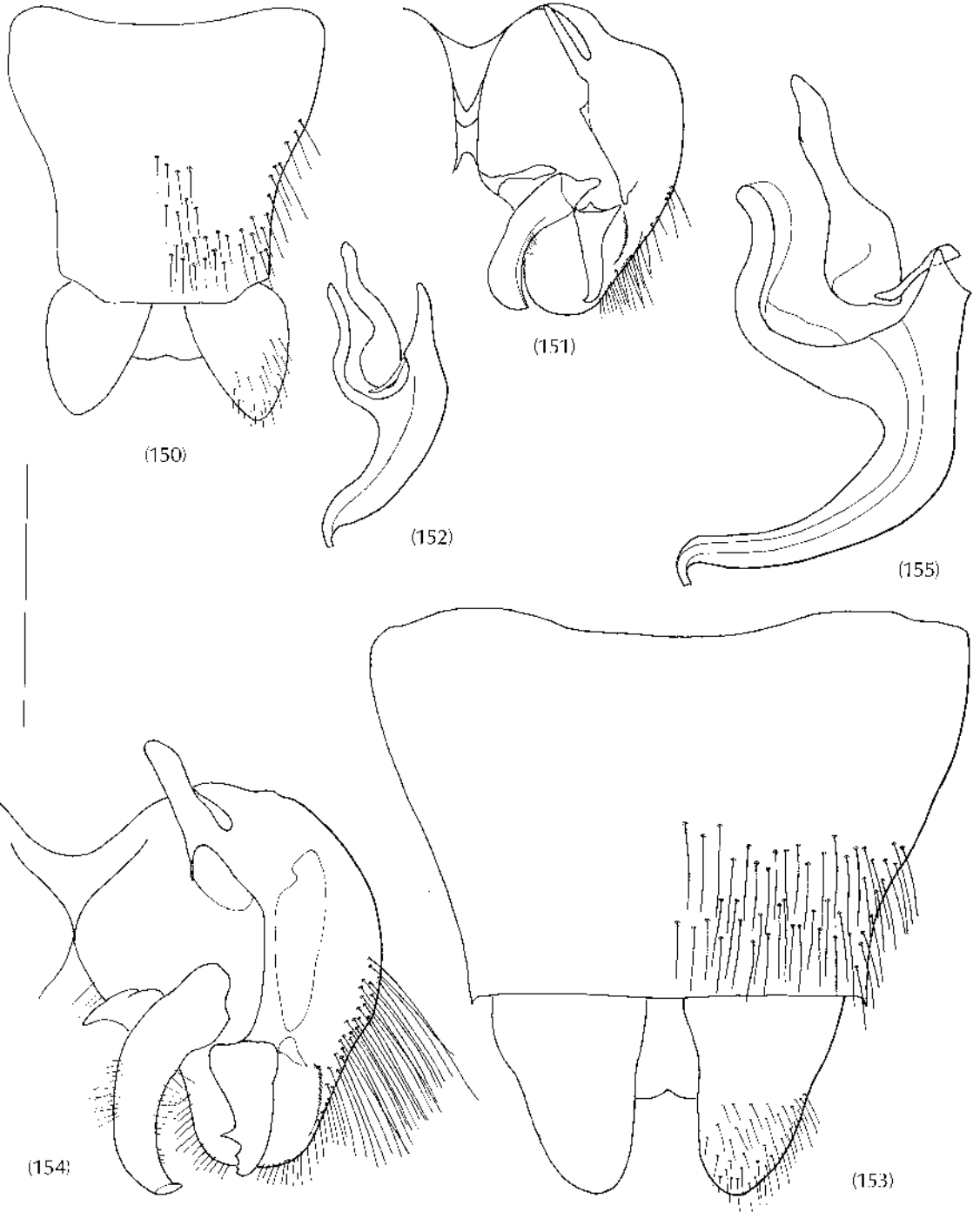

Fig. 150–152 *A. microphallus*: (150) epandrium; (151) gonocoxite; (152) aedeagus.
 Fig. 153–155 *A. neglectus*: (153) epandrium; (154) gonocoxite; (155) aedeagus.

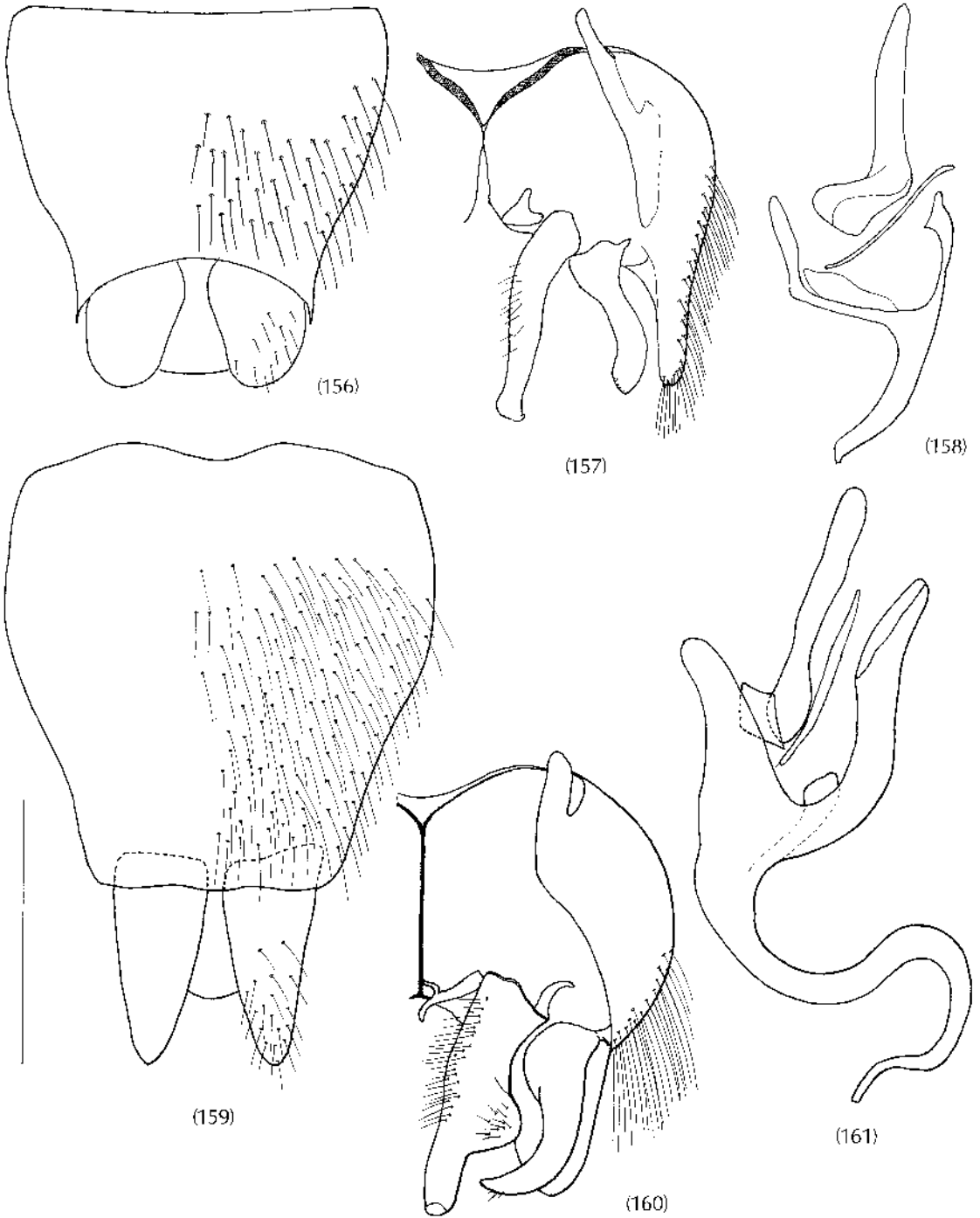

Fig. 156-158 *A. nebulosus*: (156) epandrium; (157) gonocoxite; (158) aedeagus.
 Fig. 159-161 *A. ostentatus*: (159) epandrium; (160) gonocoxite; (161) aedeagus.

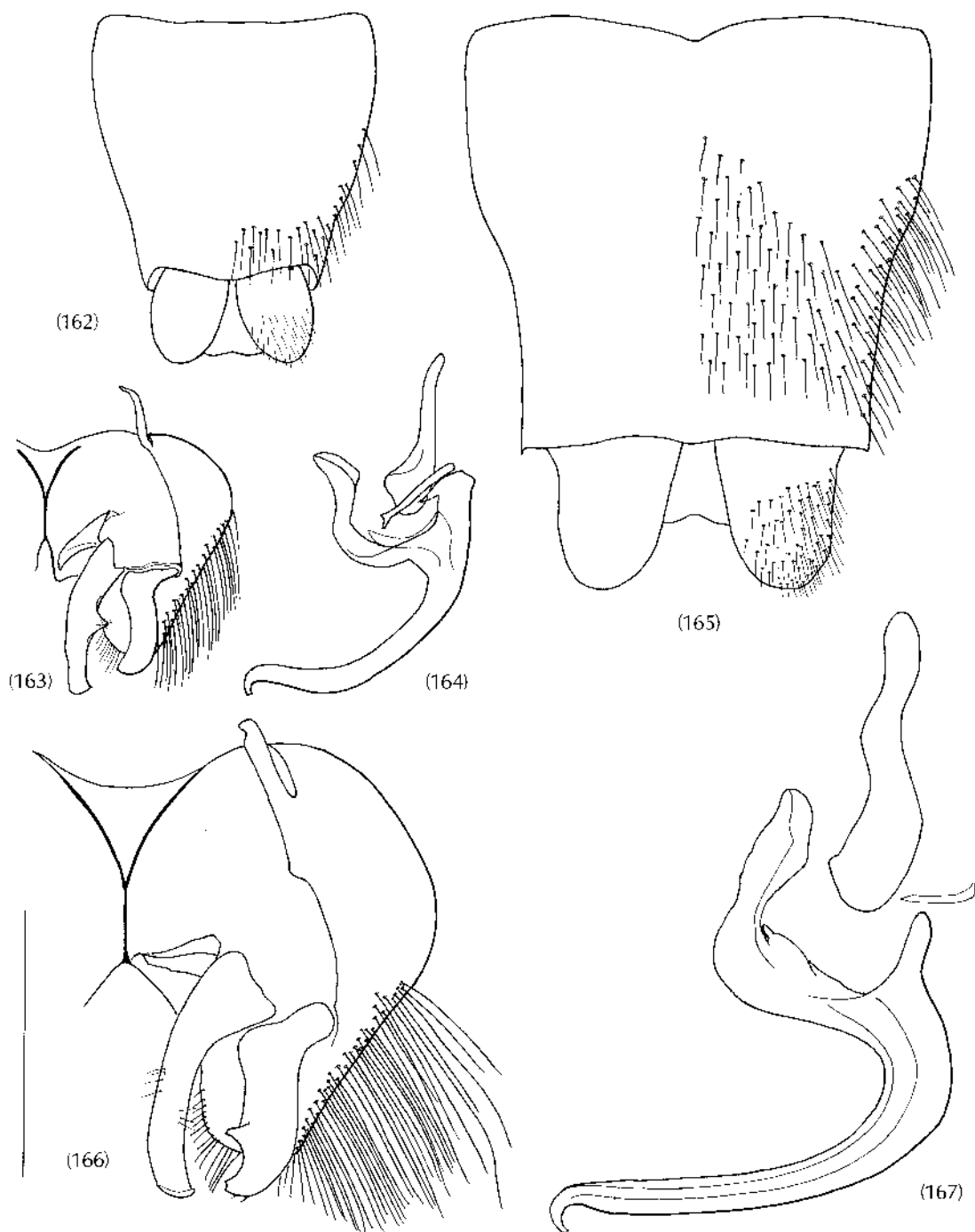

Fig. 162–164 *A. nigrofemoratus*: (162) epandrium; (163) gonocoxite; (164) aedeagus.
 Fig. 165–167 *A. robustus*: (165) epandrium; (166) gonocoxite; (167) aedeagus.

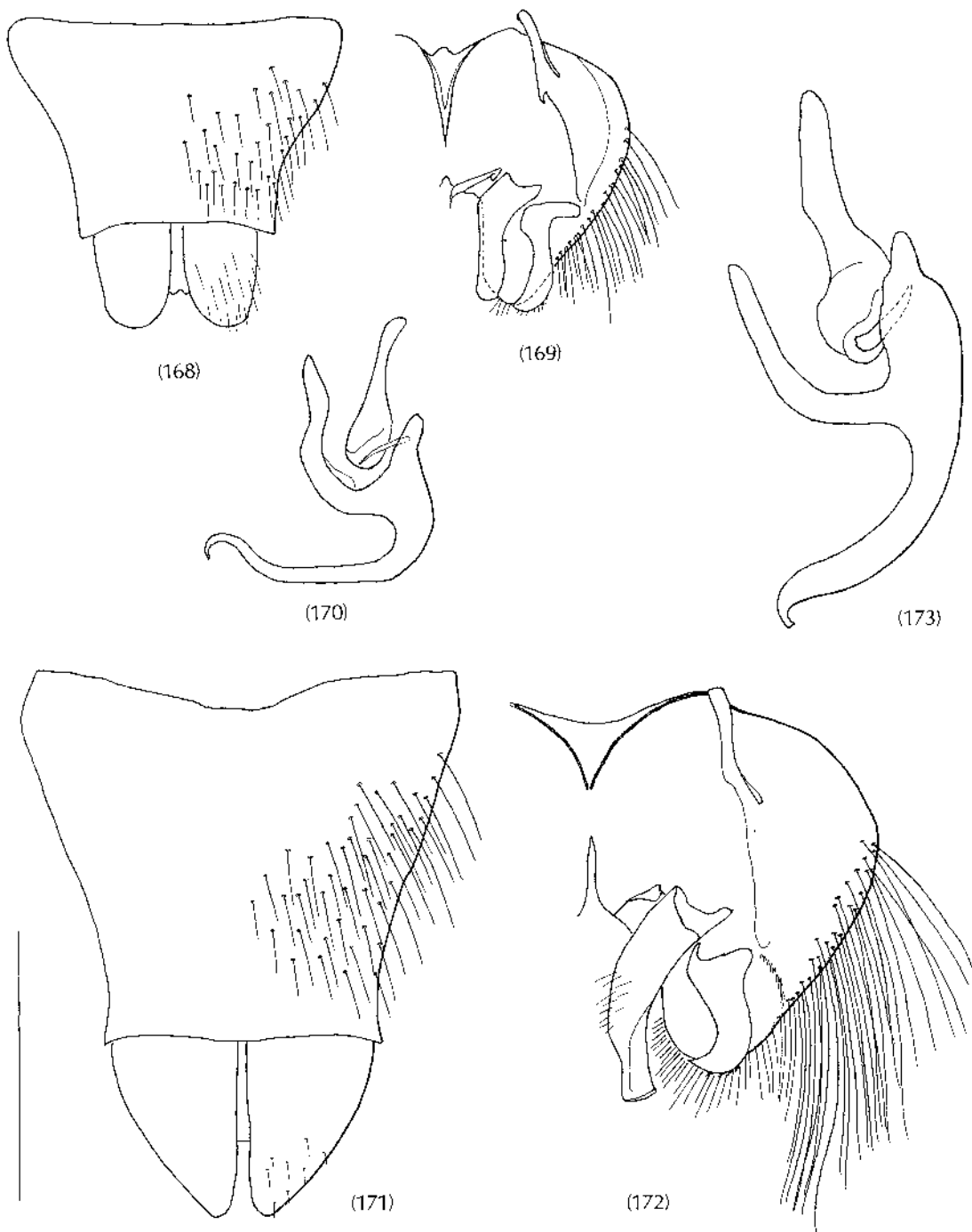

Fig. 168–170 *A. postocularis*: (168) epandrium; (169) gonocoxite; (170) aedeagus.
Fig. 171–173 *A. ruficoxa*: (171) epandrium; (172) gonocoxite; (173) aedeagus.

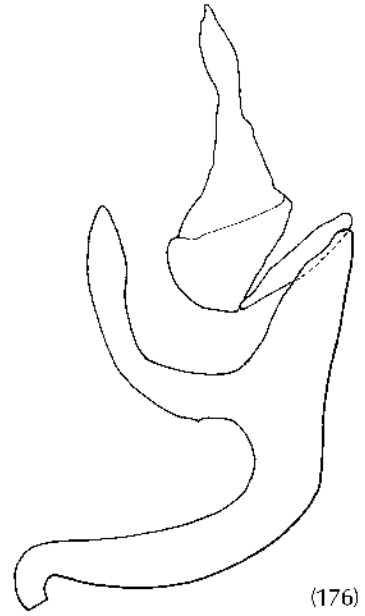
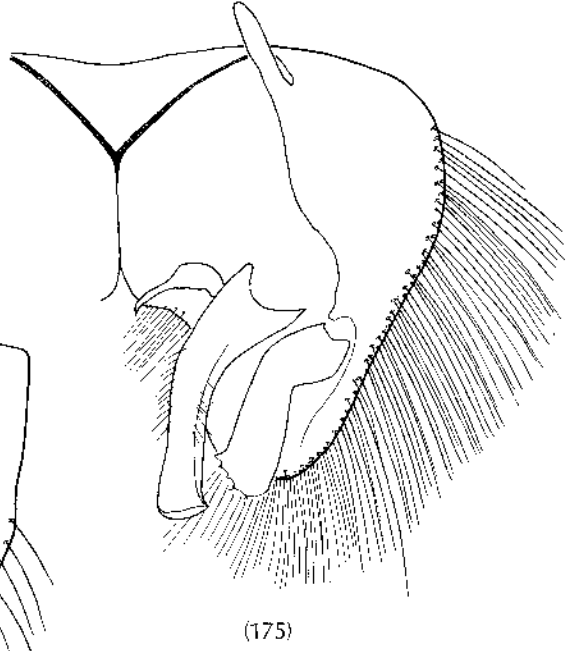
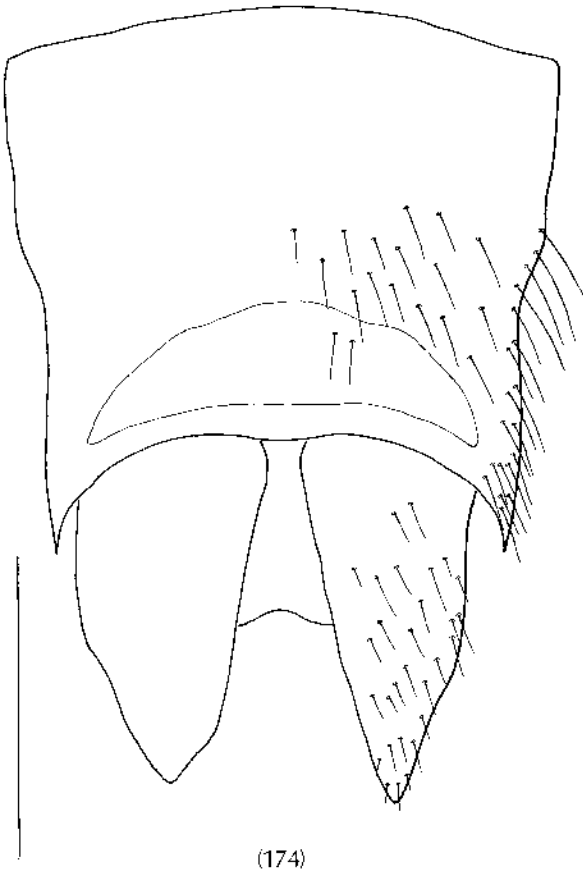

Fig. 174-176 *A. rufobasalis*: (174) epandrium; (175) gonocoxite; (176) aedeagus.

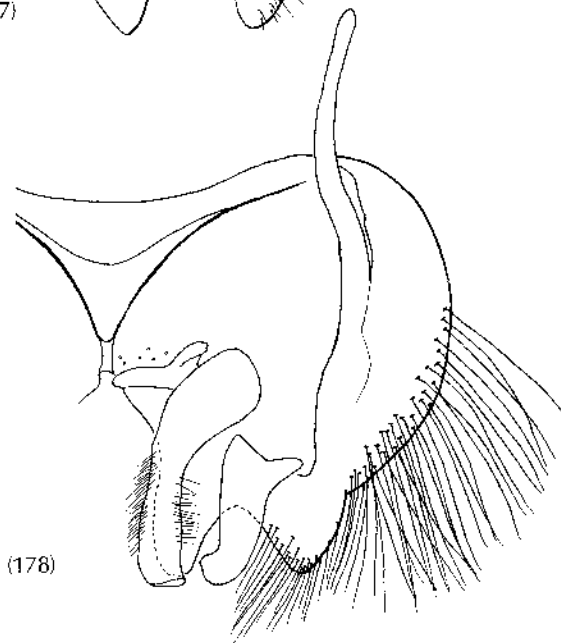
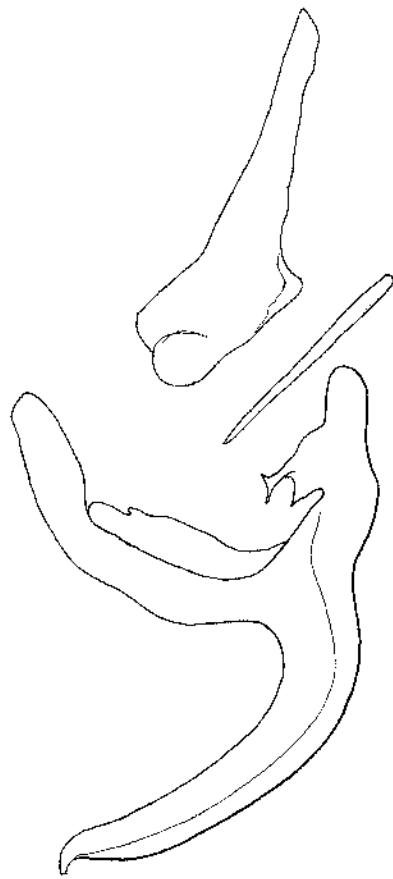
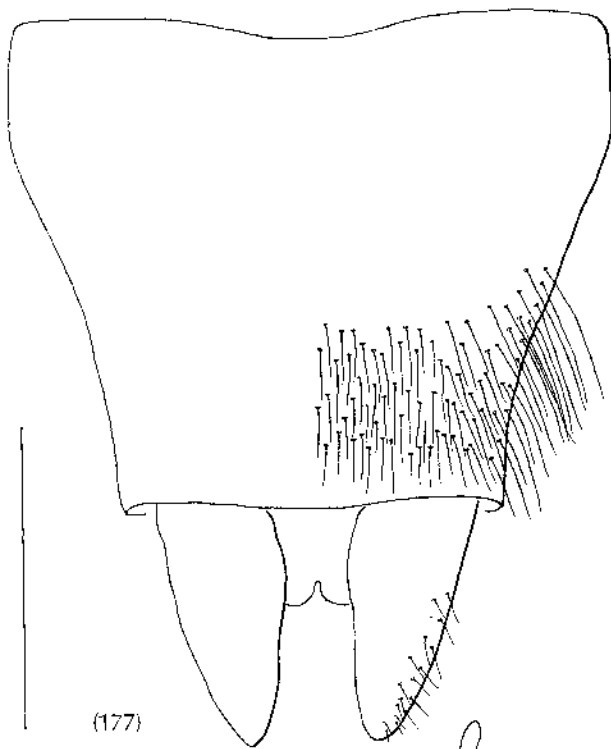
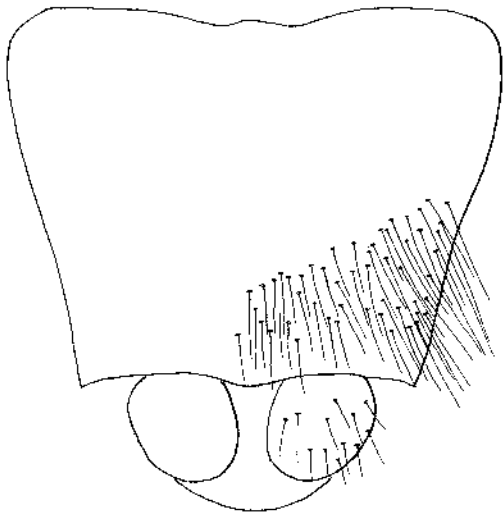
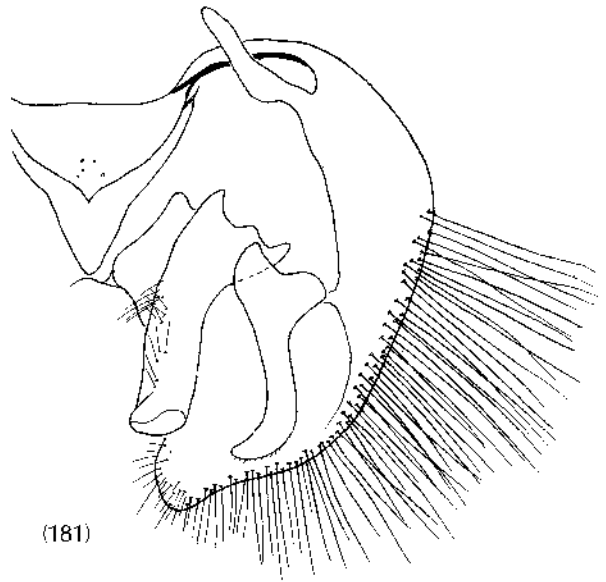

Fig. 177-179 *A. schlingeri*: (177) epandrium; (178) gonocoxite; (179) aedeagus.



(180)



(181)

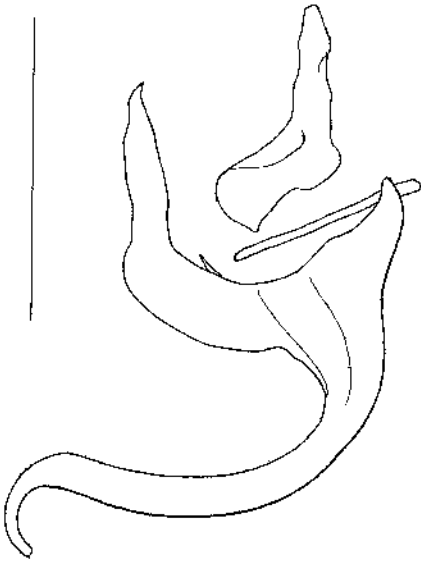

(182)

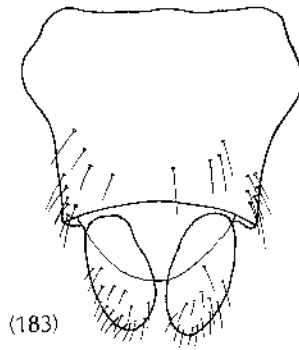

(183)

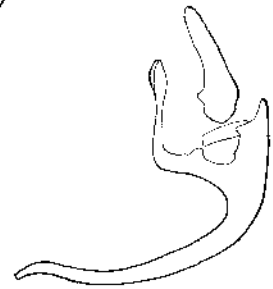

(185)

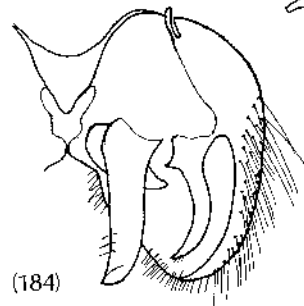

(184)

Fig. 180–182 *A. similis*: (180) epandrium; (181) gonocoxite; (182) aedeagus.
Fig. 183–185 *A. simplex*: (183) epandrium; (184) gonocoxite; (185) aedeagus.

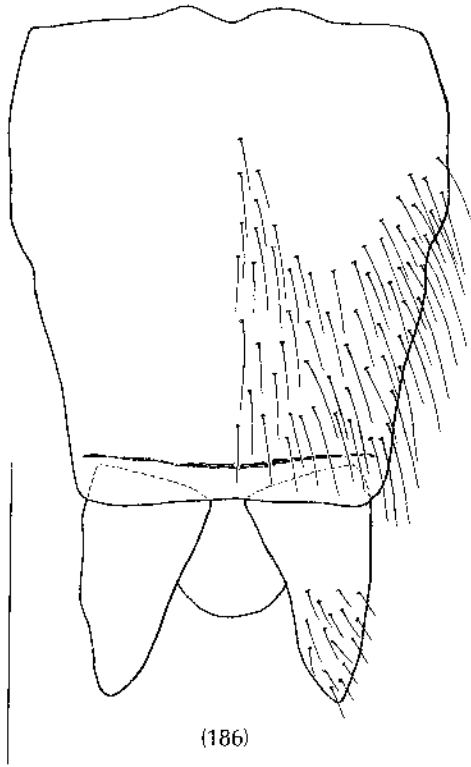

(186)

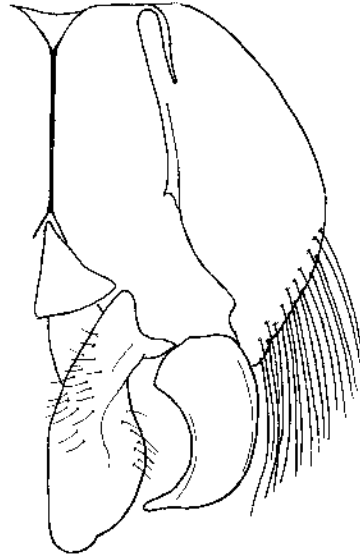

(187)

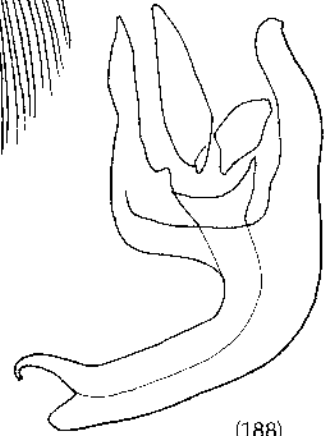

(188)

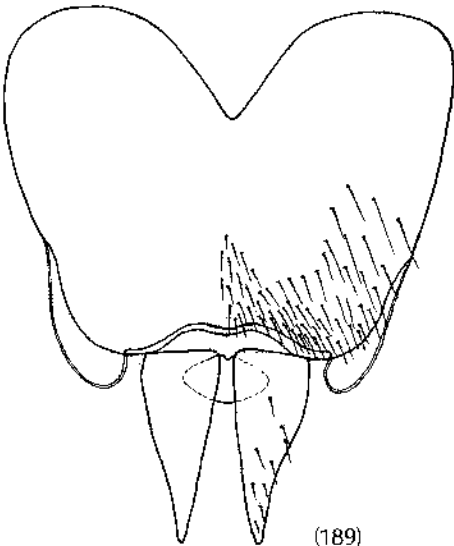

(189)

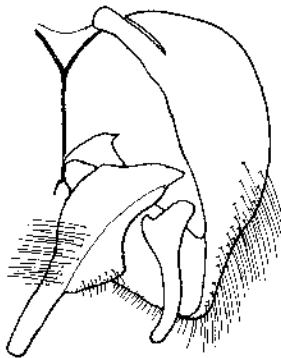

(190)

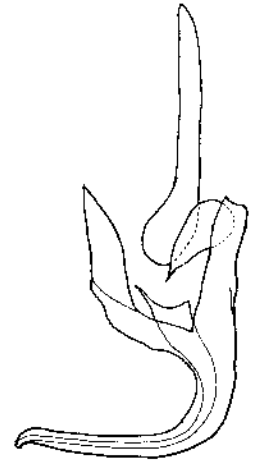

(191)

Fig. 186–188 *A. spiniger*: (186) epandrium; (187) gonocoxite; (188) aedeagus.
Fig. 189–191 *A. spitzeri*: (189) epandrium; (190) gonocoxite; (191) aedeagus.

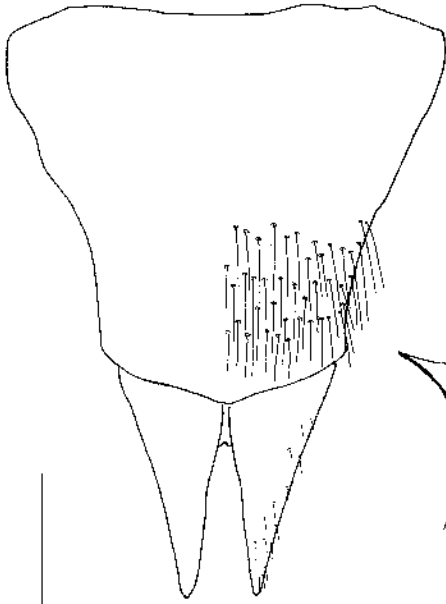

(192)

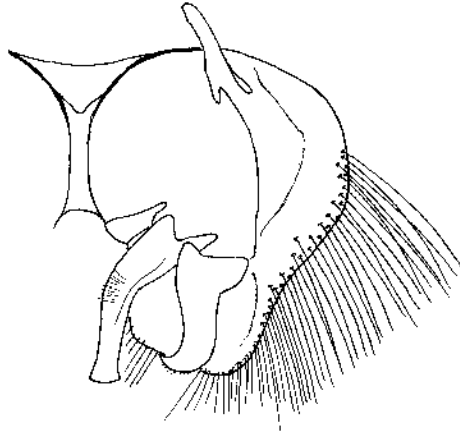

(193)

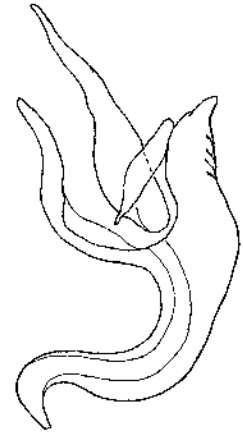

(194)

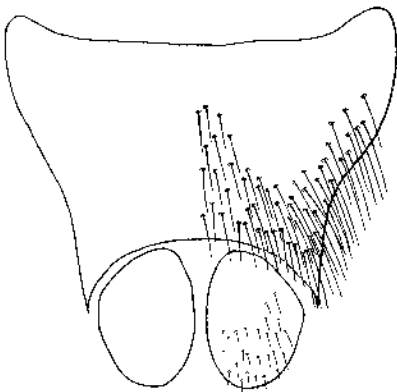

(195)

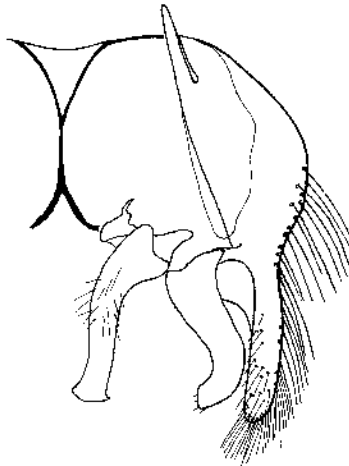

(196)

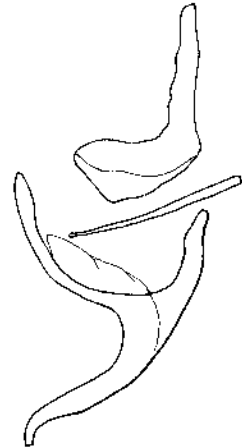

(197)

Fig. 192–194 *A. triangularis*: (192) epandrium; (193) gonocoxite; (194) aedeagus.
Fig. 195–197 *A. tricoloratus*: (195) epandrium; (196) gonocoxite; (197) aedeagus.

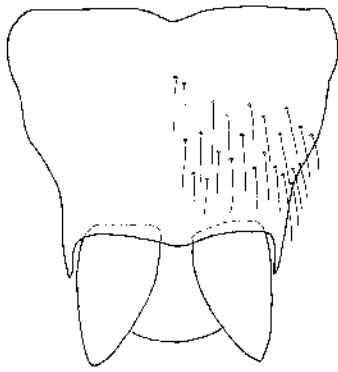

(198)

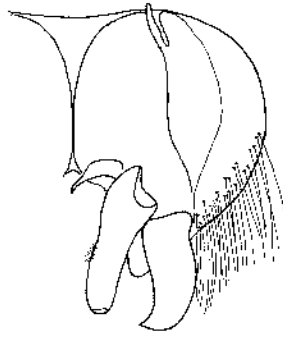

(199)

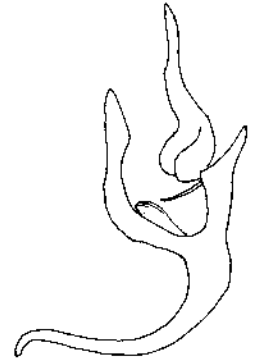

(200)

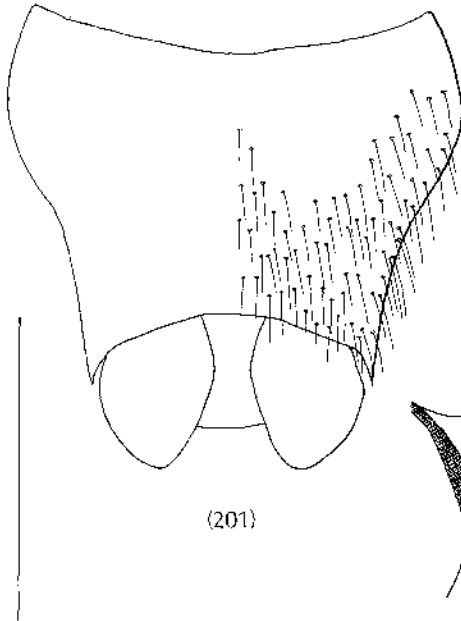

(201)

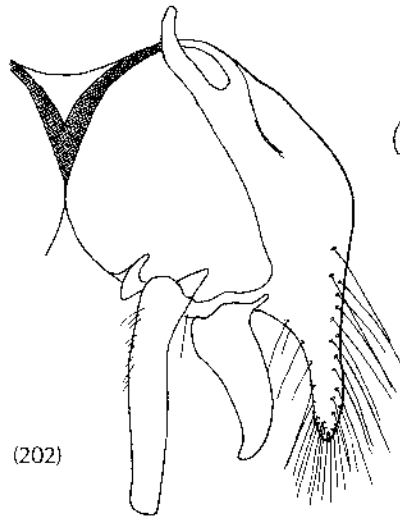

(202)

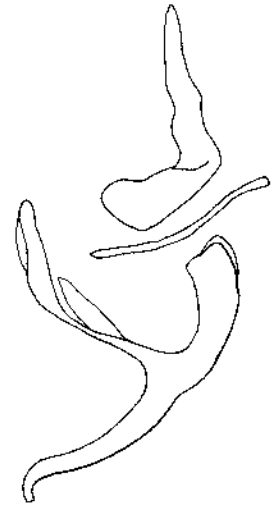

(203)

Fig. 198–200 *A. waitarerensis*: (198) epandrium; (199) gonocoxite; (200) aedeagus.
Fig. 201–203 *A. westlandensis*: (201) epandrium; (202) gonocoxite; (203) aedeagus.

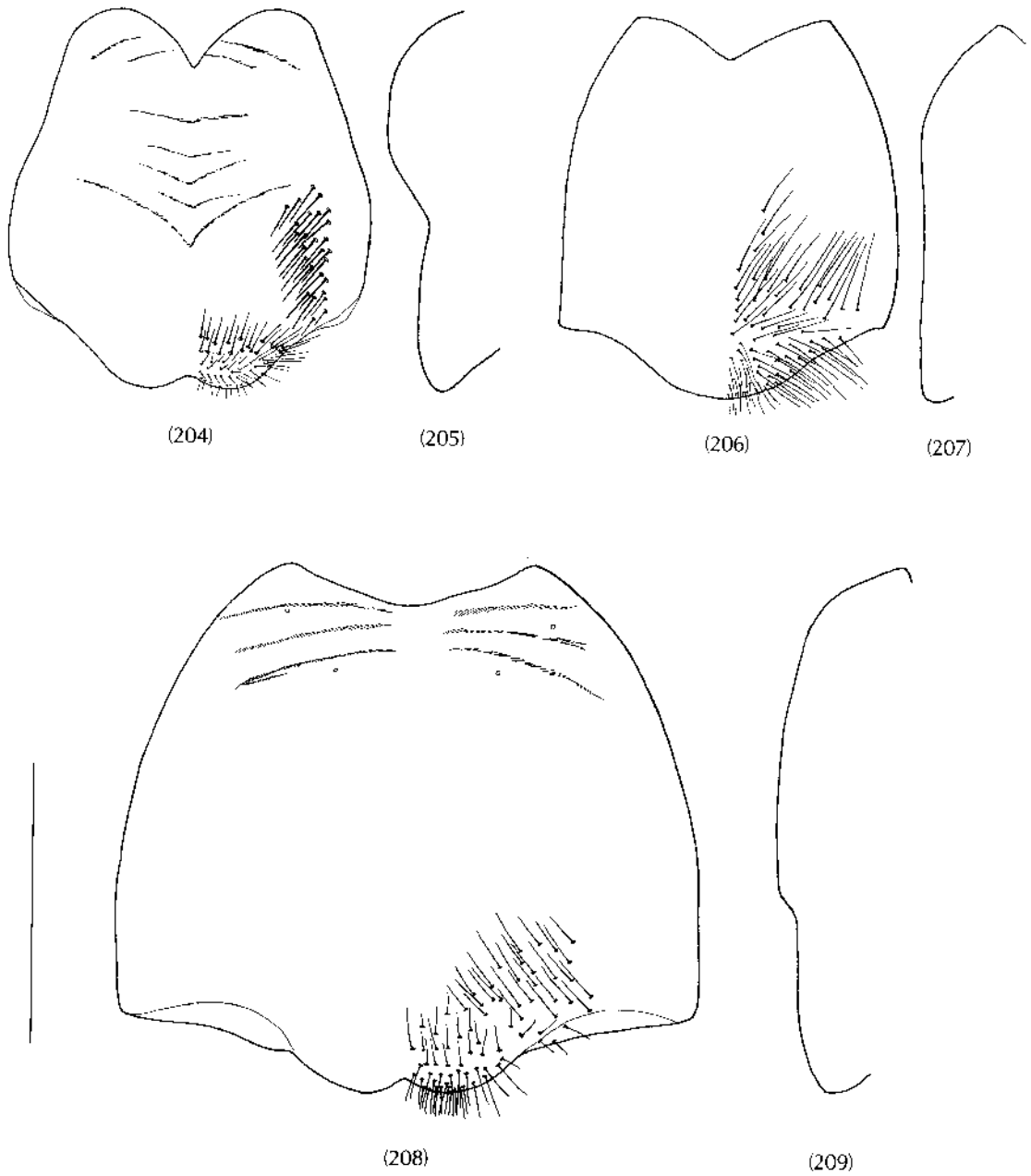

Fig. 204–307 Female sternite 8, *Anabarhynchus* species, in face view and lateral profile. Scale line: 0.5 mm.
 (204, 205) *A. acuminatus*; (206, 207) *A. arenarius*; (208, 209) *A. atripes*.

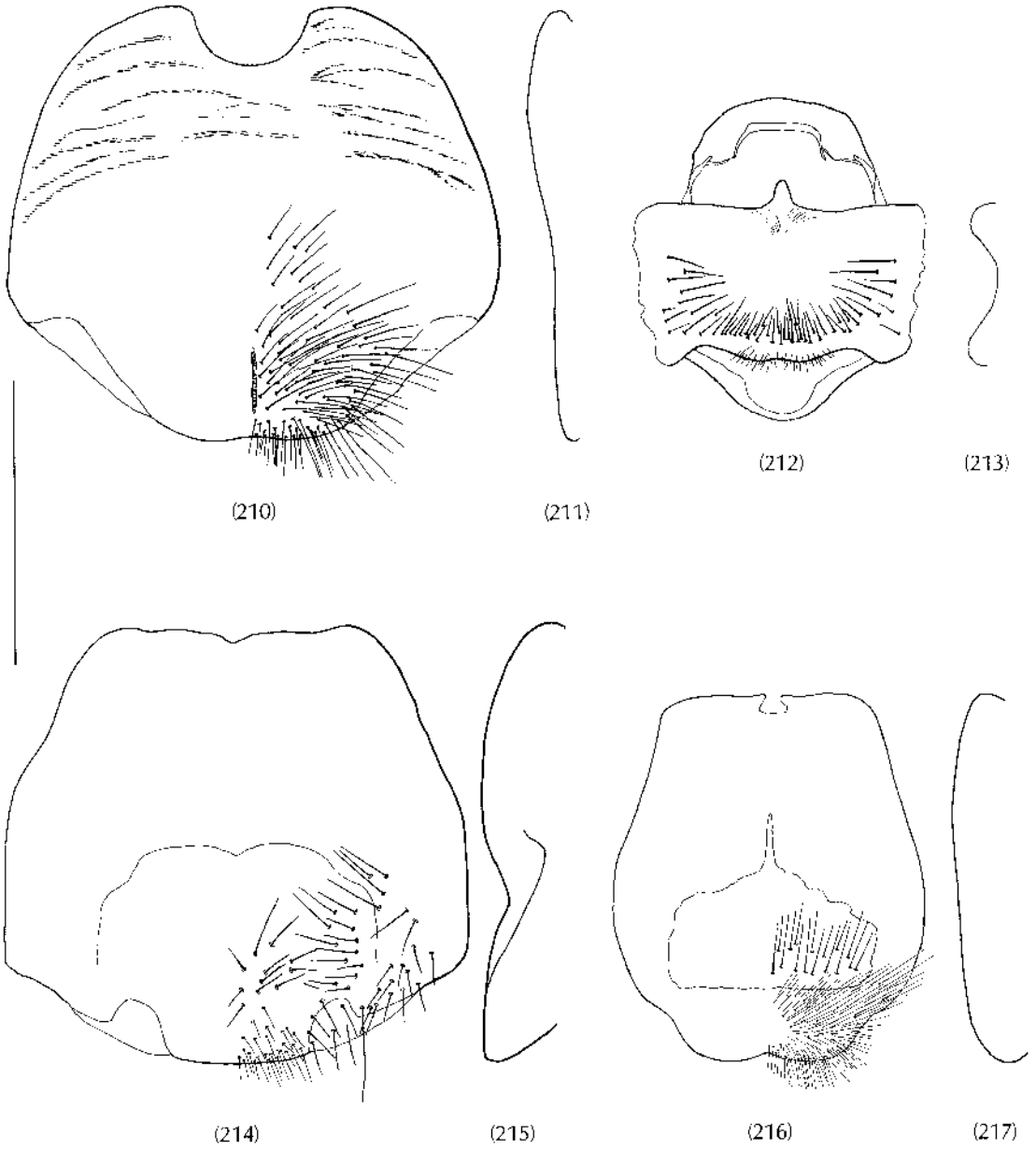

Fig. 210–217 Female sternite 8: (210, 211) *A. brunneris*; (212, 213) *A. aureosericeus*; (214, 215) *A. caesius*; (216, 217) *A. brevicornis*.

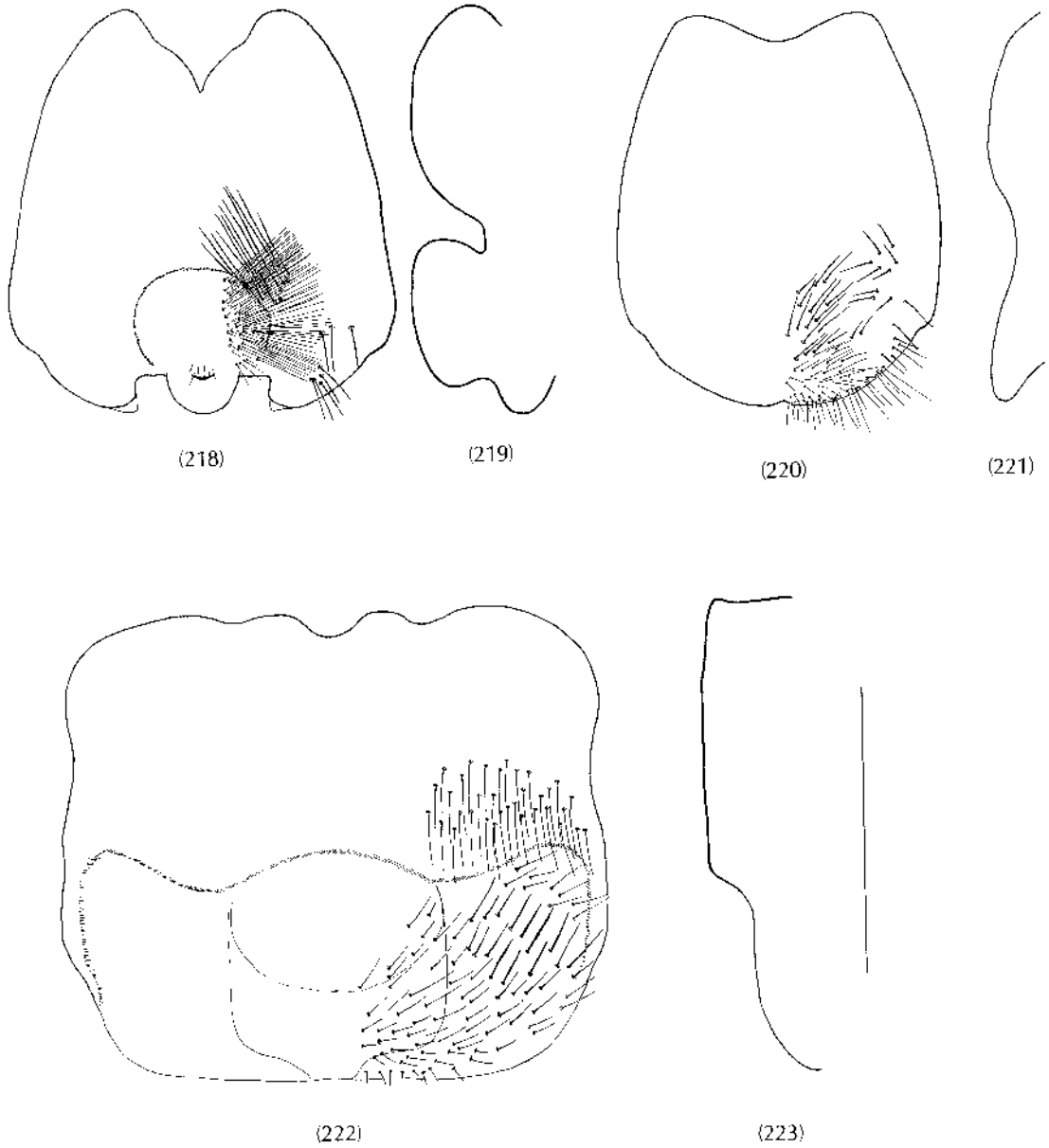

Fig. 218–223 Female sternite 8: (218, 219) *A. completus*; (220, 221) *A. diversicolor*; (222, 223) *A. curvistylus*.

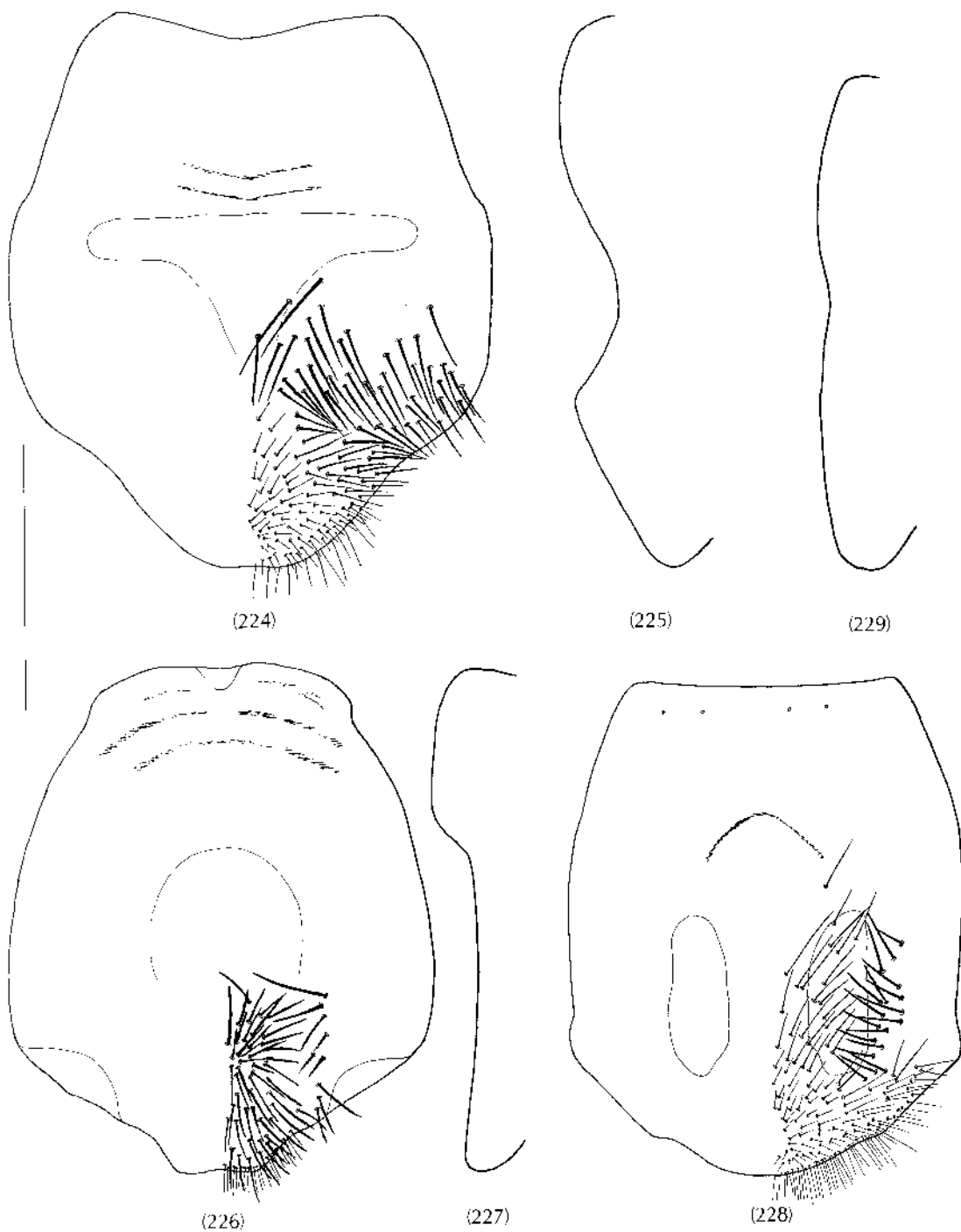

Fig. 224–229 Female sternite 8: (224, 225) *A. dugdalei*; (226, 227) *A. dysmachiformis*; (228, 229) *A. embersoni*.

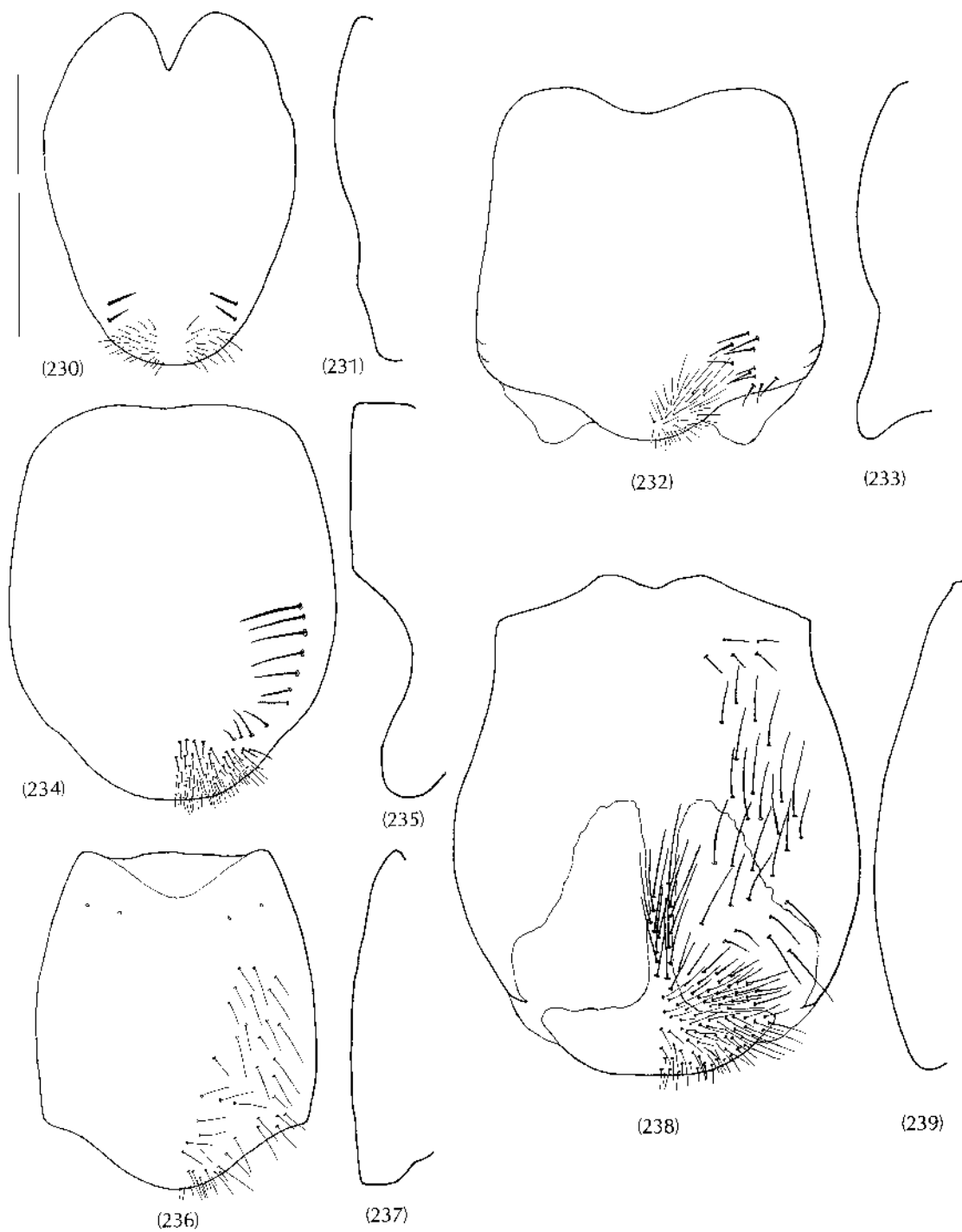
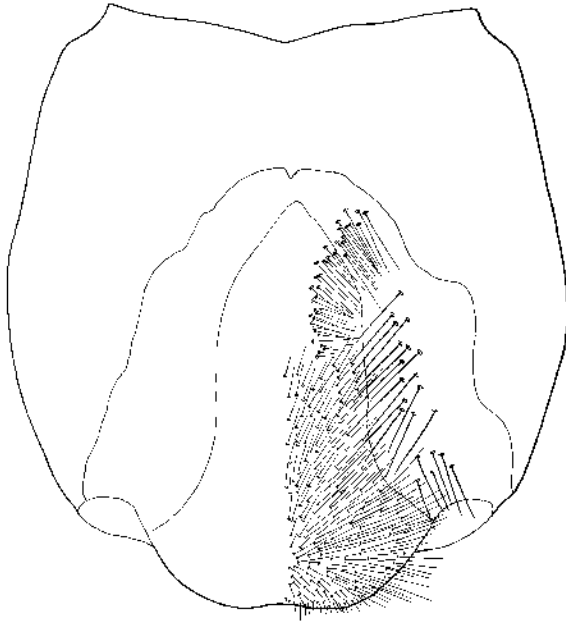

Fig. 230–239 Female sternite 8: (230, 231) *A. exiguus*; (232, 233) *A. farinosus*; (234, 235) *A. femoralis*; (236, 237) *A. fenwicki*; (238, 239) *A. fluviatilis*.



(240)



(241)

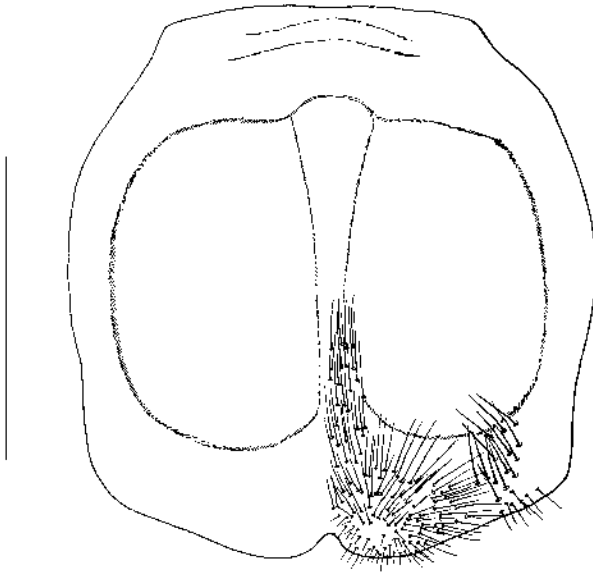

(242)



(243)

Fig. 240–243 Female sternite 8: (240, 241) *A. gibbsi*; (242, 243) *A. grossus*.

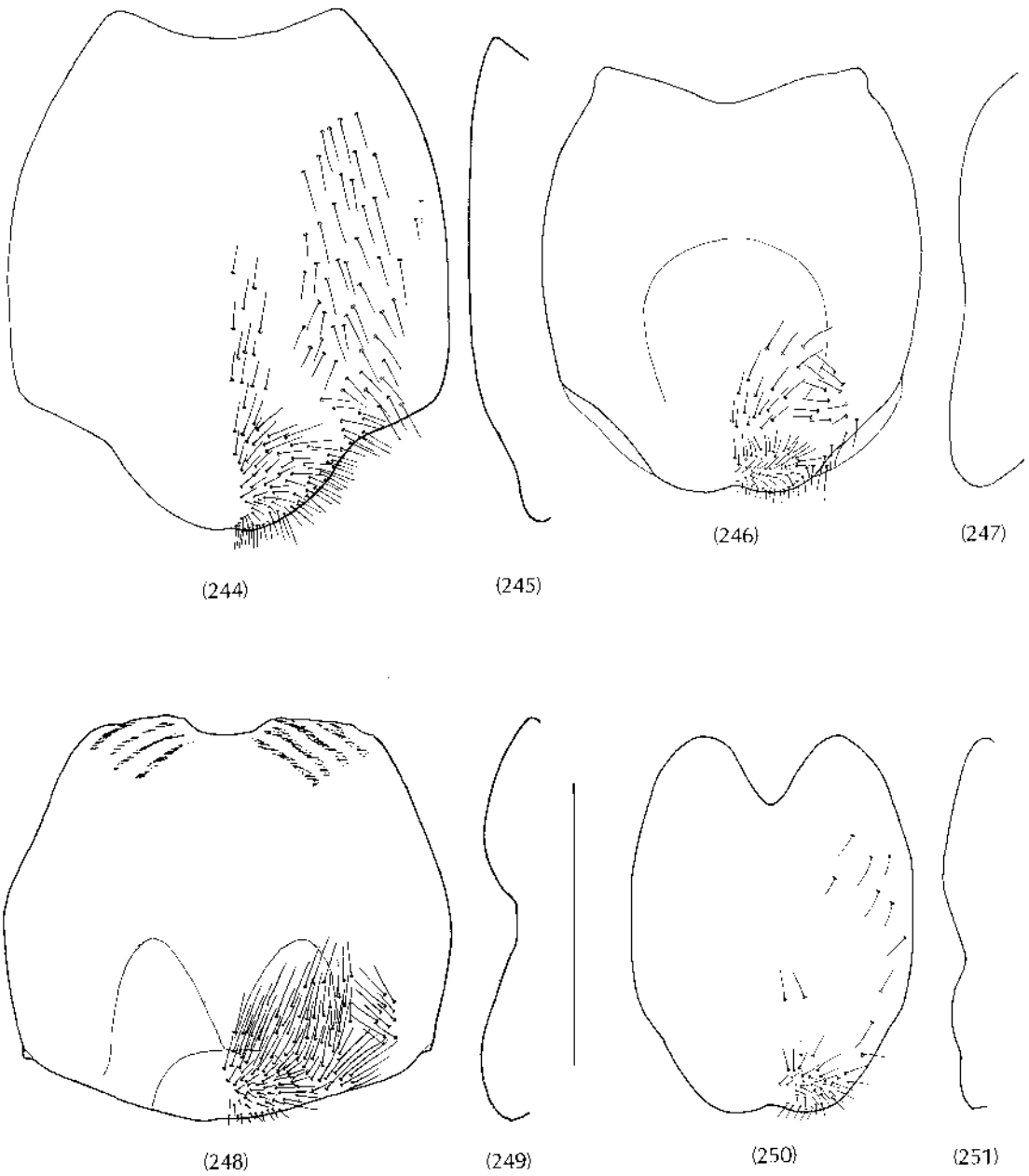

Fig. 244–251 Female sternite 8: (244, 245) *A. harrisi*; (246, 247) *A. huttoni*; (248, 249) *A. hayakawai*; (250, 251) *A. limbatinervis*.

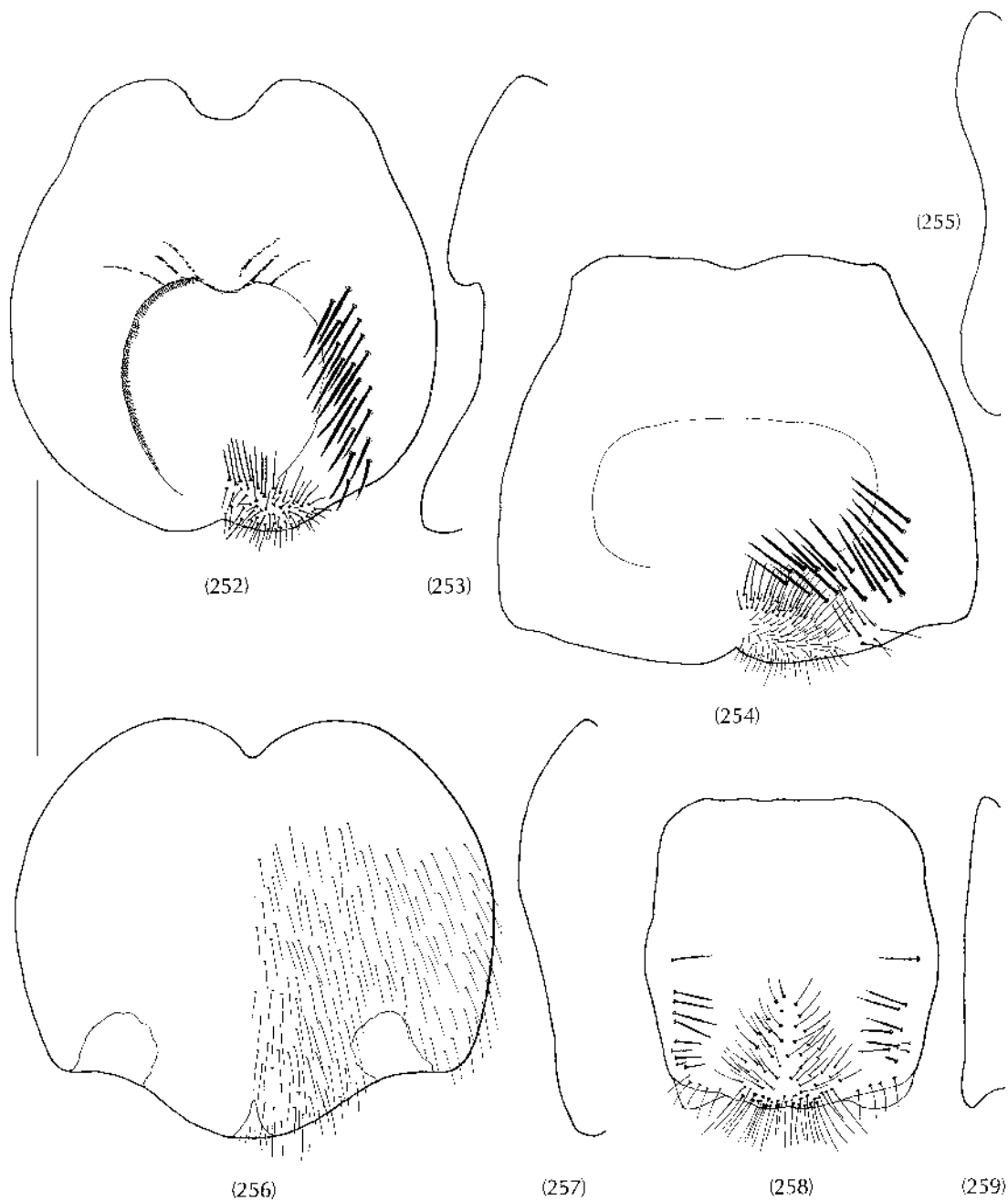

Fig. 252–259 Female sternite 8: (252, 253) *A. innotatus*; (254, 255) *A. latus*;
 (256, 257) *A. laterepilosus*; (258, 259) *A. longipennis*.

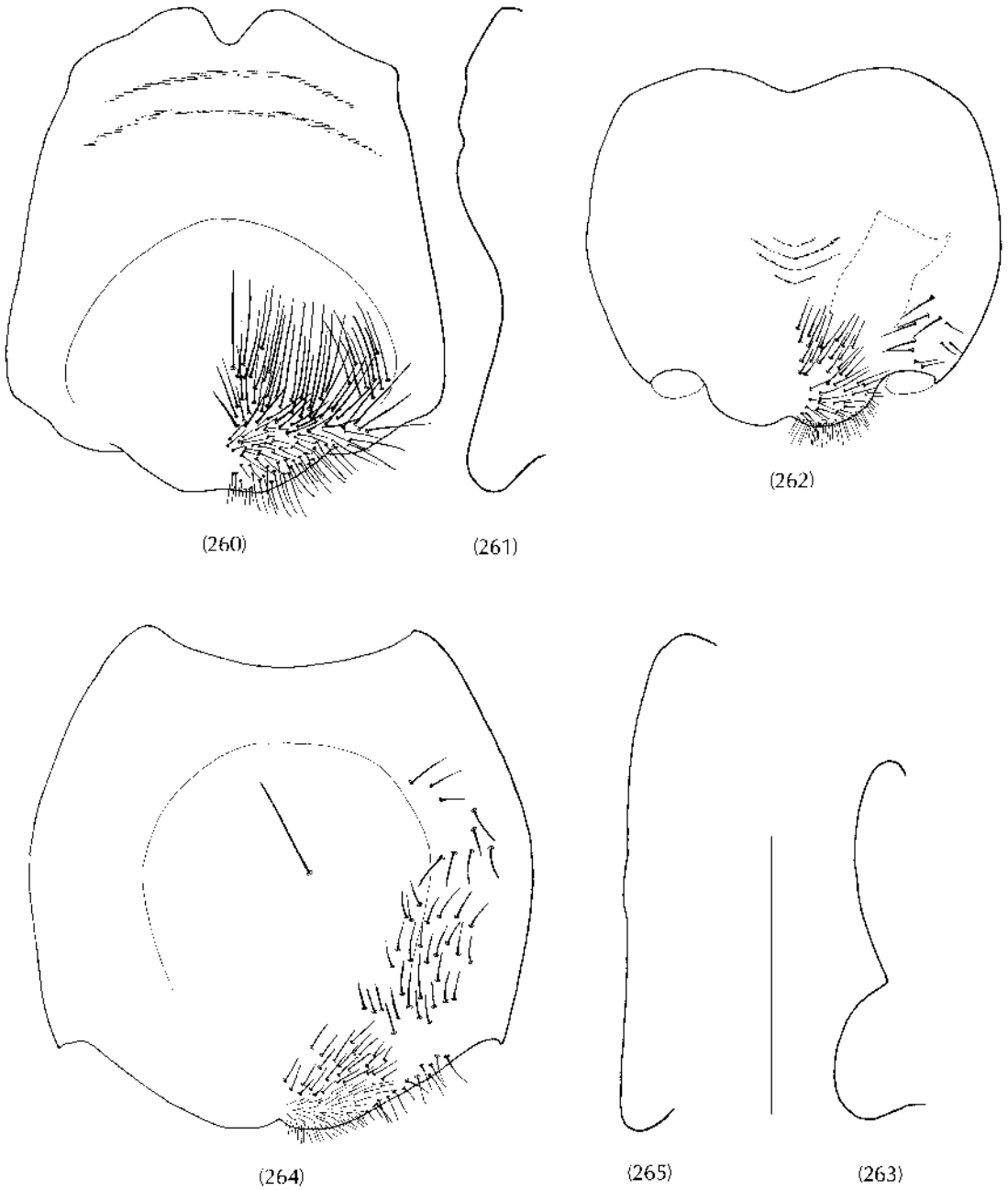

Fig. 260–265 Female sternite 8: (260, 261) *A. longepilosus*; (262, 263) *A. macfarlanei*; (264, 265) *A. major*.

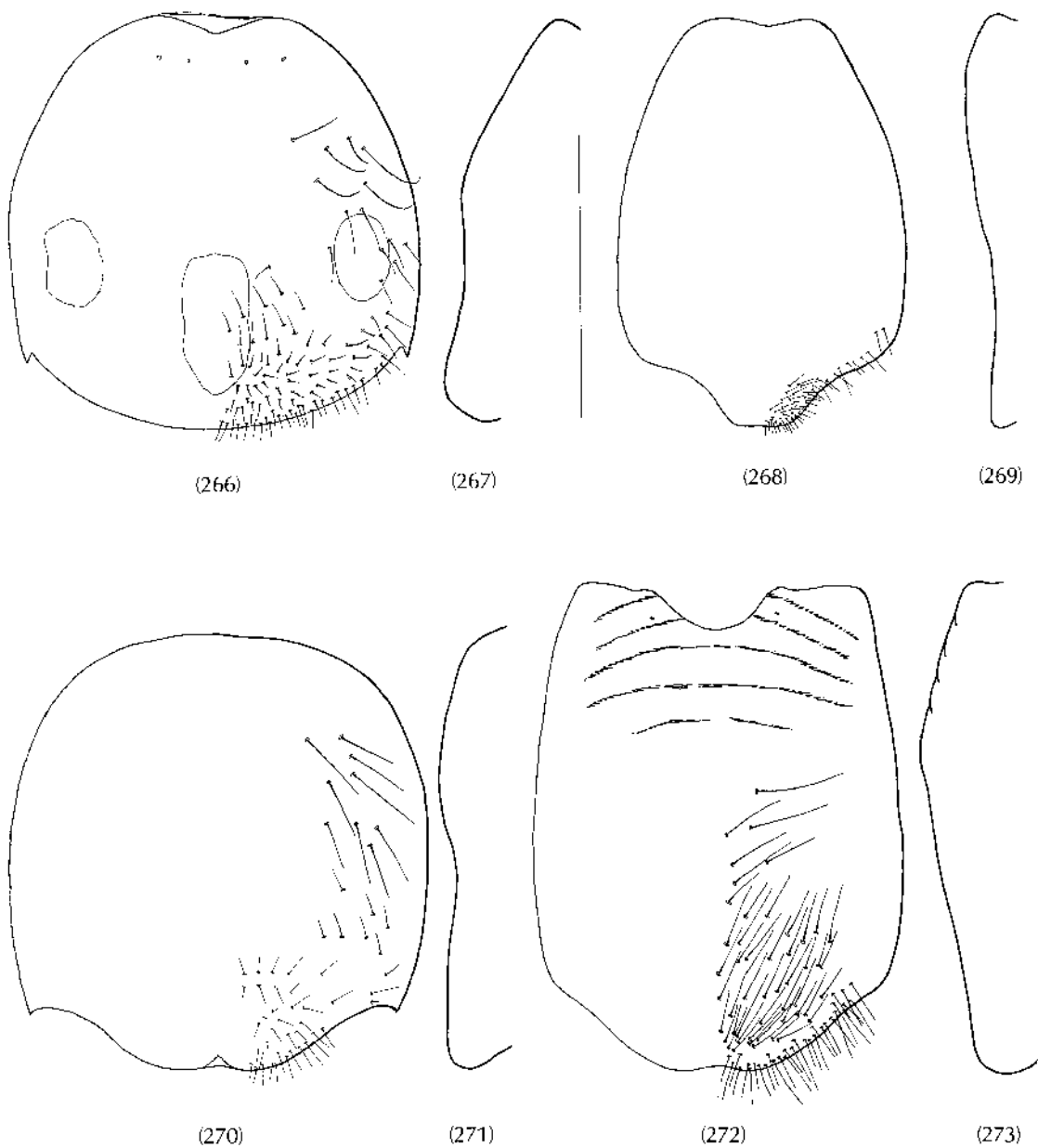

Fig. 266–273 Female sternite 8: (266, 267) *A. maori*; (268, 269) *A. microphallus*; (270, 271) *A. megalopyge*; (272, 273) *A. monticola*.

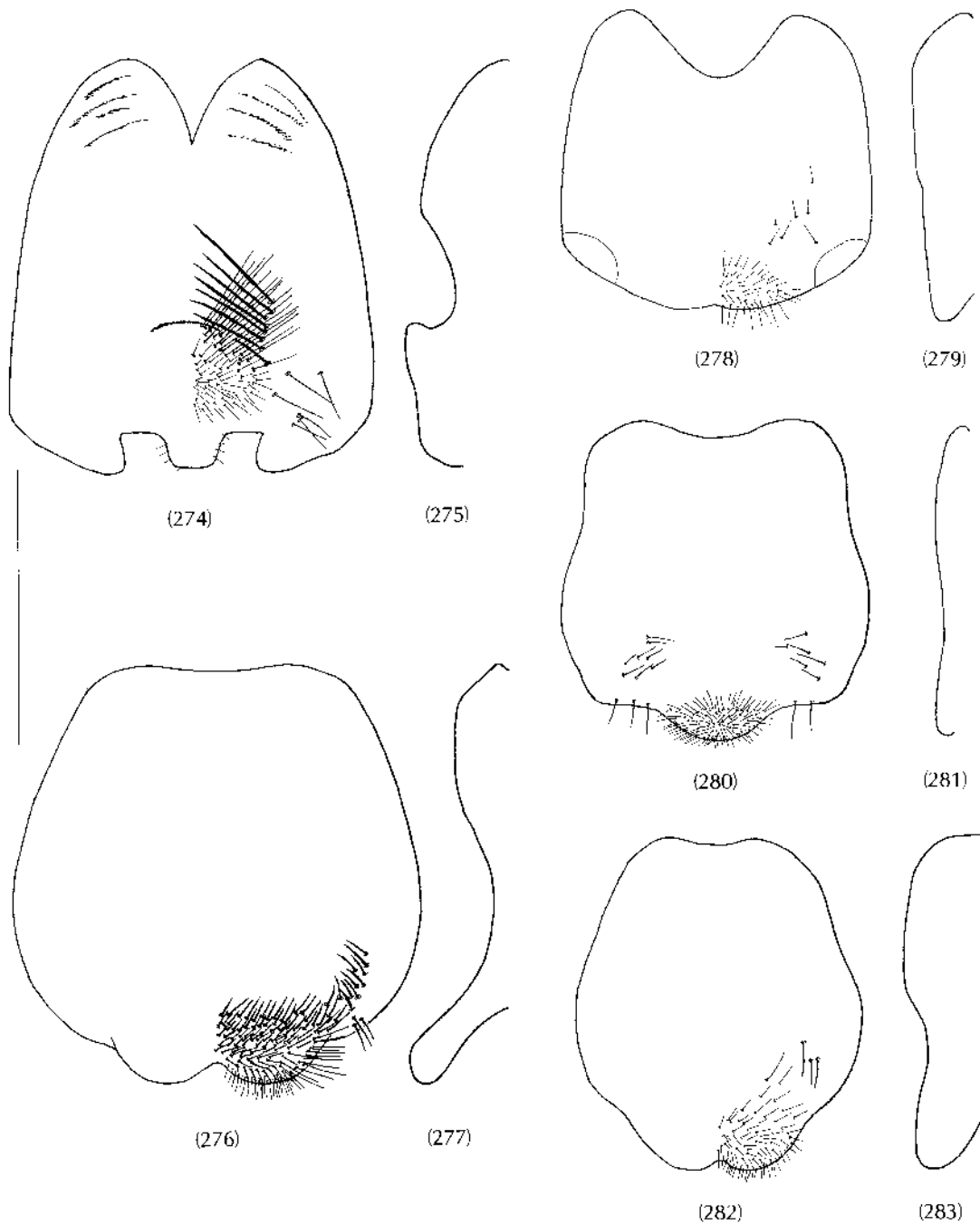

Fig. 274–283 Female sternite 8: (274, 275) *A. nebulosus*; (276, 277) *A. neglectus*; (278, 279) *A. olivaceus*; (280, 281) *A. nigrofemoratus*; (282, 283) *A. postocularis*.

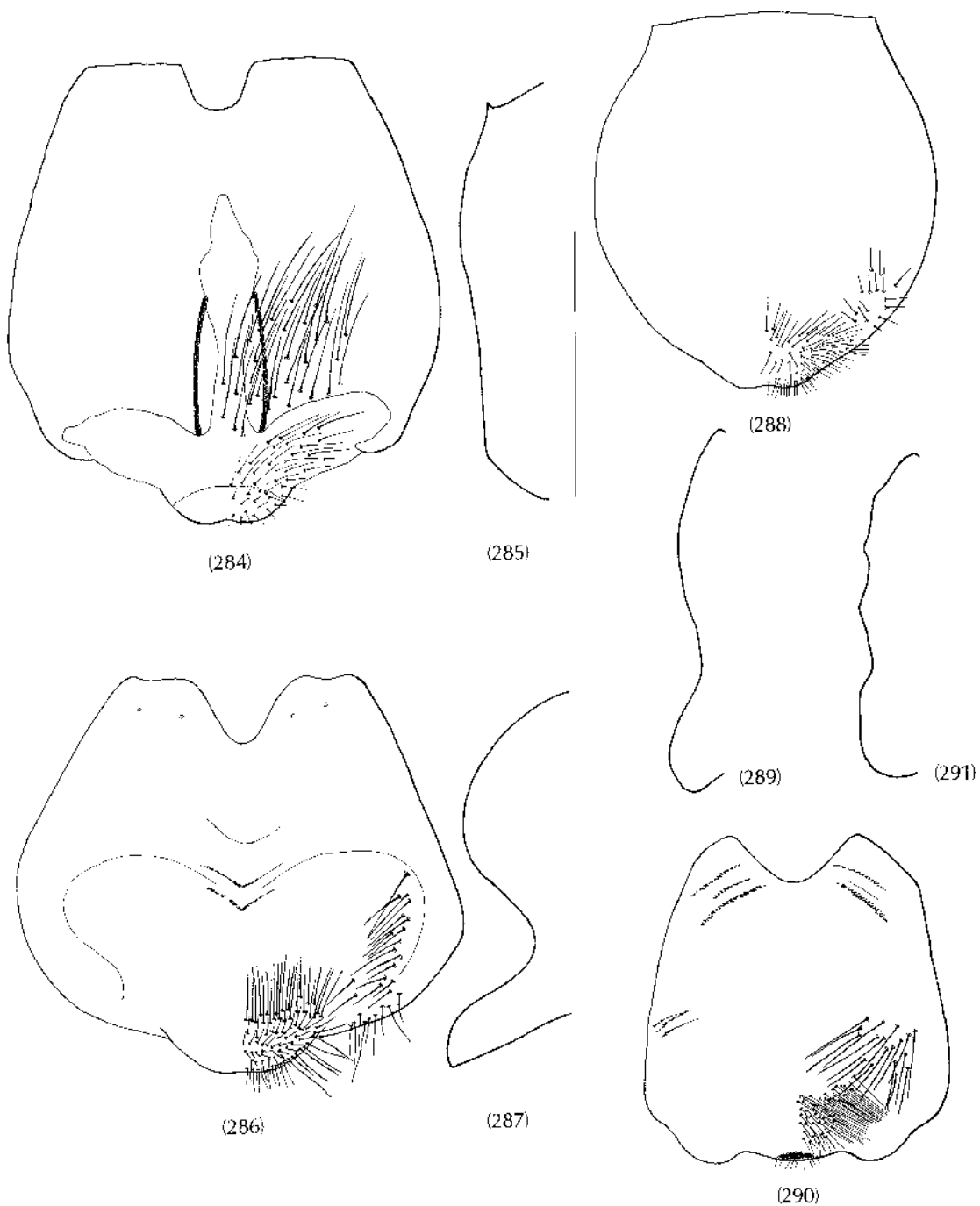

Fig. 284–291 Female sternite 8: (284, 285) *A. ostentatus*; (286, 287) *A. robustus*; (288, 289) *A. ruficoxa*; (290, 291) *A. tricoloratus*.

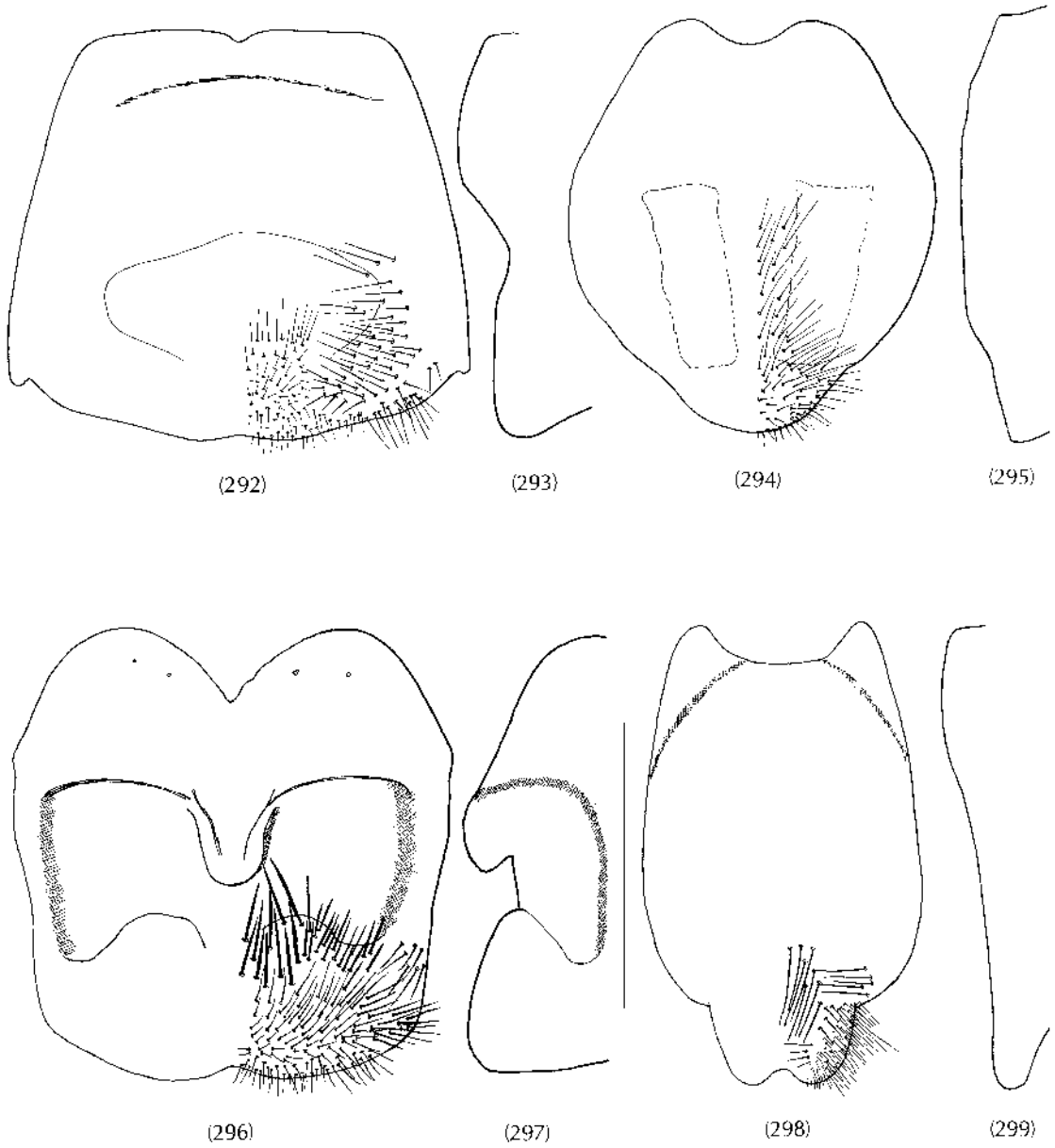

Fig. 292–299 Female sternite 8: (292, 293) *A. rufobasalis*; (294, 295) *A. spiniger*; (296, 297) *A. schlingerii*; (298, 299) *A. triangularis*.

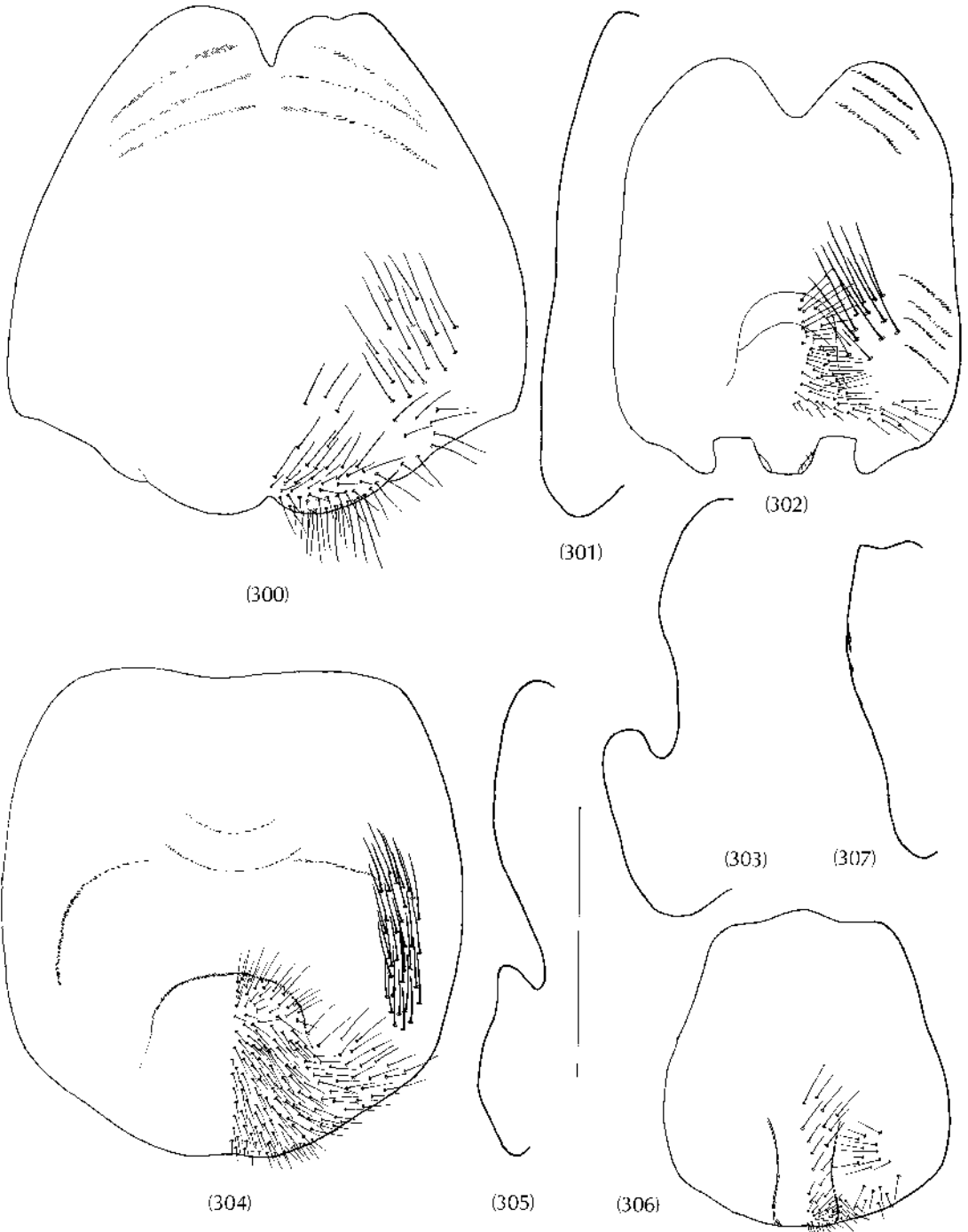

Fig. 300–307 Female sternite 8: (300, 301) *A. similis*; (302, 303) *A. westlandensis*; (304, 305) *A. wisei*; (306, 307) *A. waitarensis*.

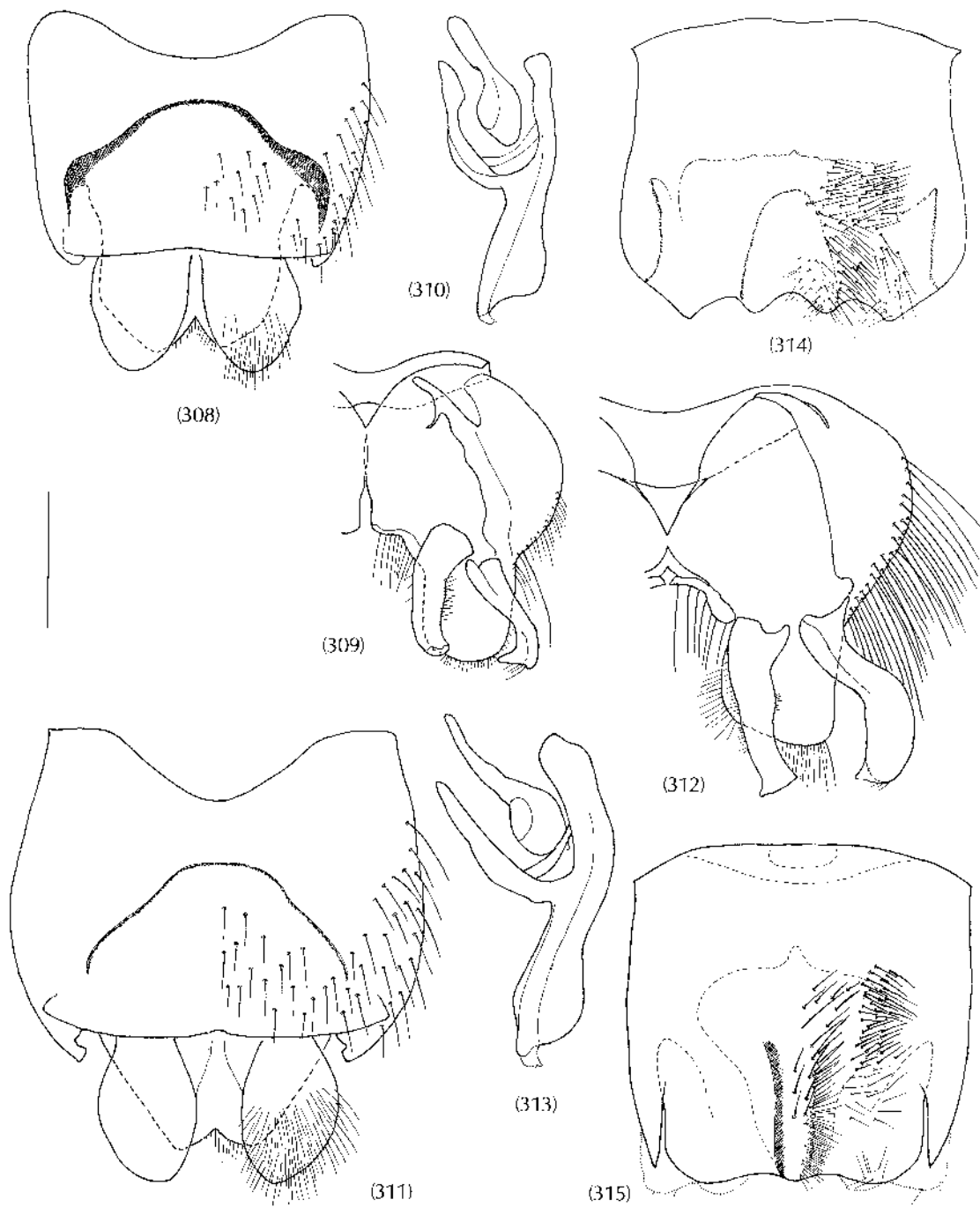

Fig. 308–313 Male genitalia, *Megathereva* species: (308–310) *M. albopilosa*, epandrium and cerci, dorsal; gonocoxite with appendages, dorsal; and aedeagus, lateral. (311–313) *M. atritibia*, ditto.
 Fig. 314, 315 Female sternite 8, dorsal, *Megathereva albopilosa* (314) and *M. atritibia* (315). Scale line: 0.5 mm.

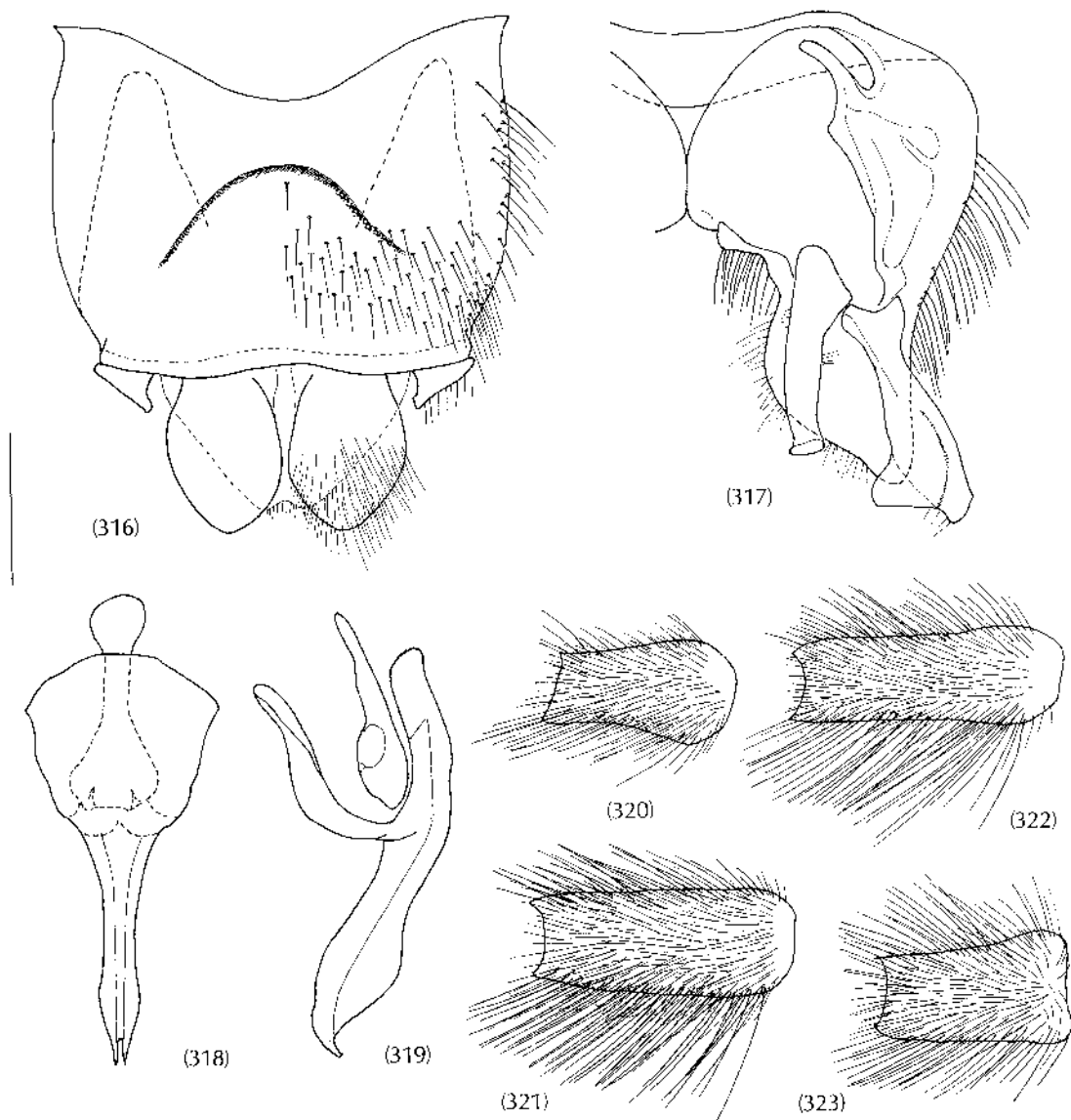

Fig. 316–319 Male genitalia, *Megathereva bilineata*: (316) epandrium and cerci, dorsal; (317) gonocoxite with appendages, dorsal; (318) aedeagus, dorsal; (319) aedeagus, lateral.
Fig. 320–323 Antennal scape, *Megathereva* species: (320) *albopilosa*; (321) *atritibia*; (322) *bilineata*; (323) sp. aff. *bilineata*, Nape Nape (see text, p. 69). Scale line: 0.5 mm.

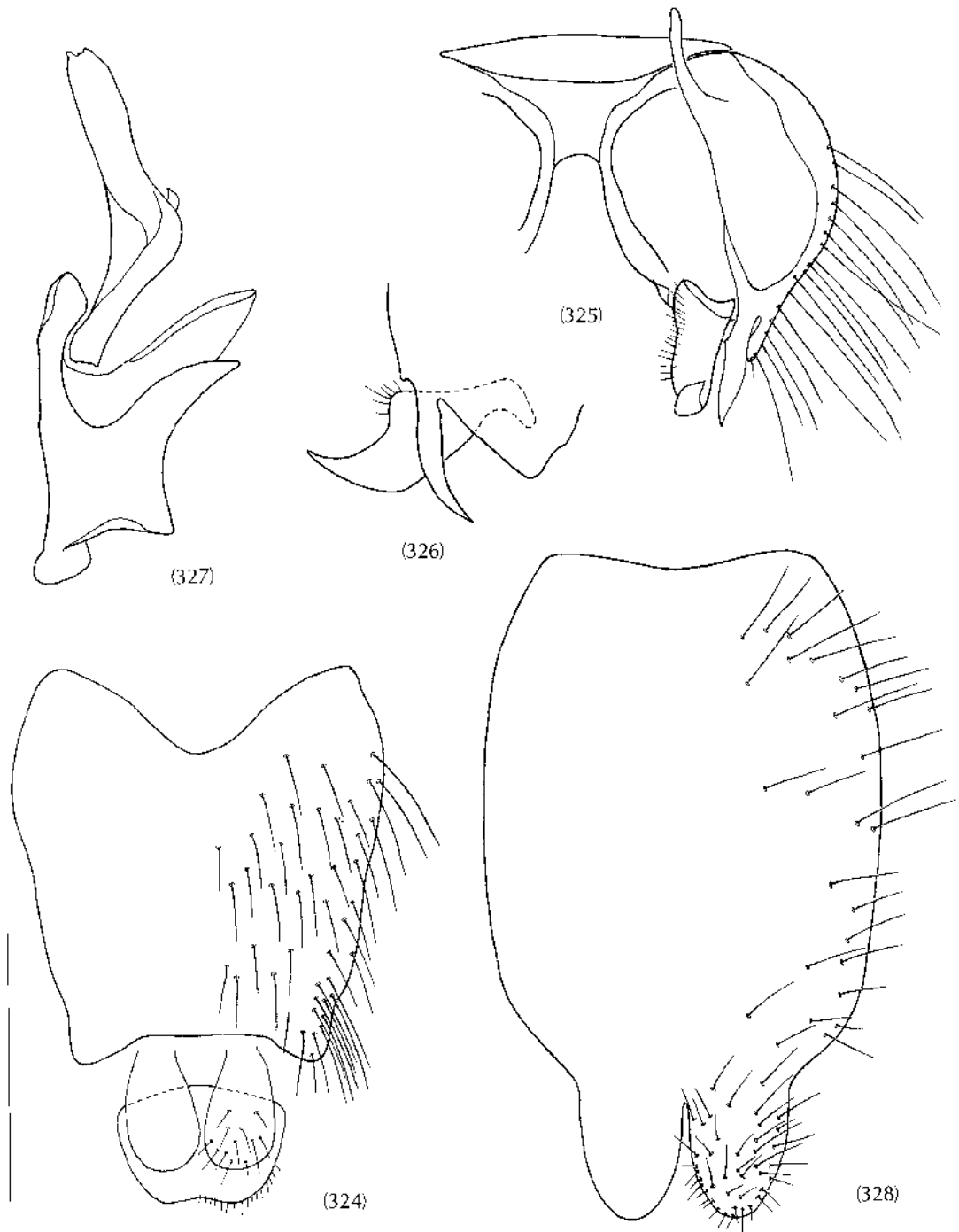

Fig. 324–328 *Ectinorhynchus castaneus*: (324) epandrium and cerci, dorsal; (325) gonocoxite with appendages, dorsal; (326) apex of gonocoxite and inner style, lateral; (327) aedeagus, lateral; (328) female sternite 8, face view. Scale line: 0.5 mm.

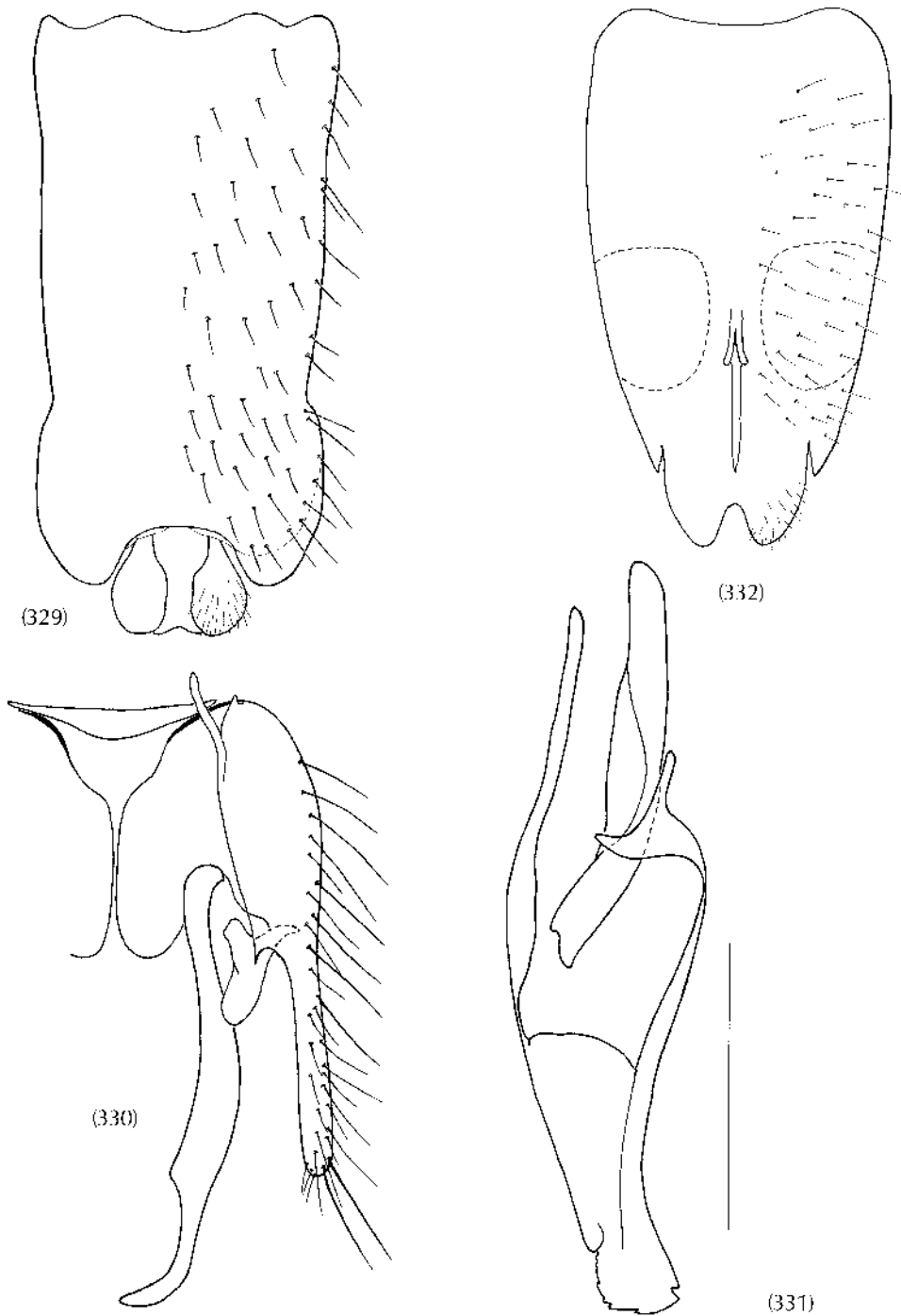

Fig. 329–332 *Ectinorhynchus cupreus*: (329) epandrium and cerci, dorsal; (330) gonocoxite with appendages, dorsal; (331) aedeagus, lateral; (332) female sternite 8, face view. Scale line: 0.5 mm.

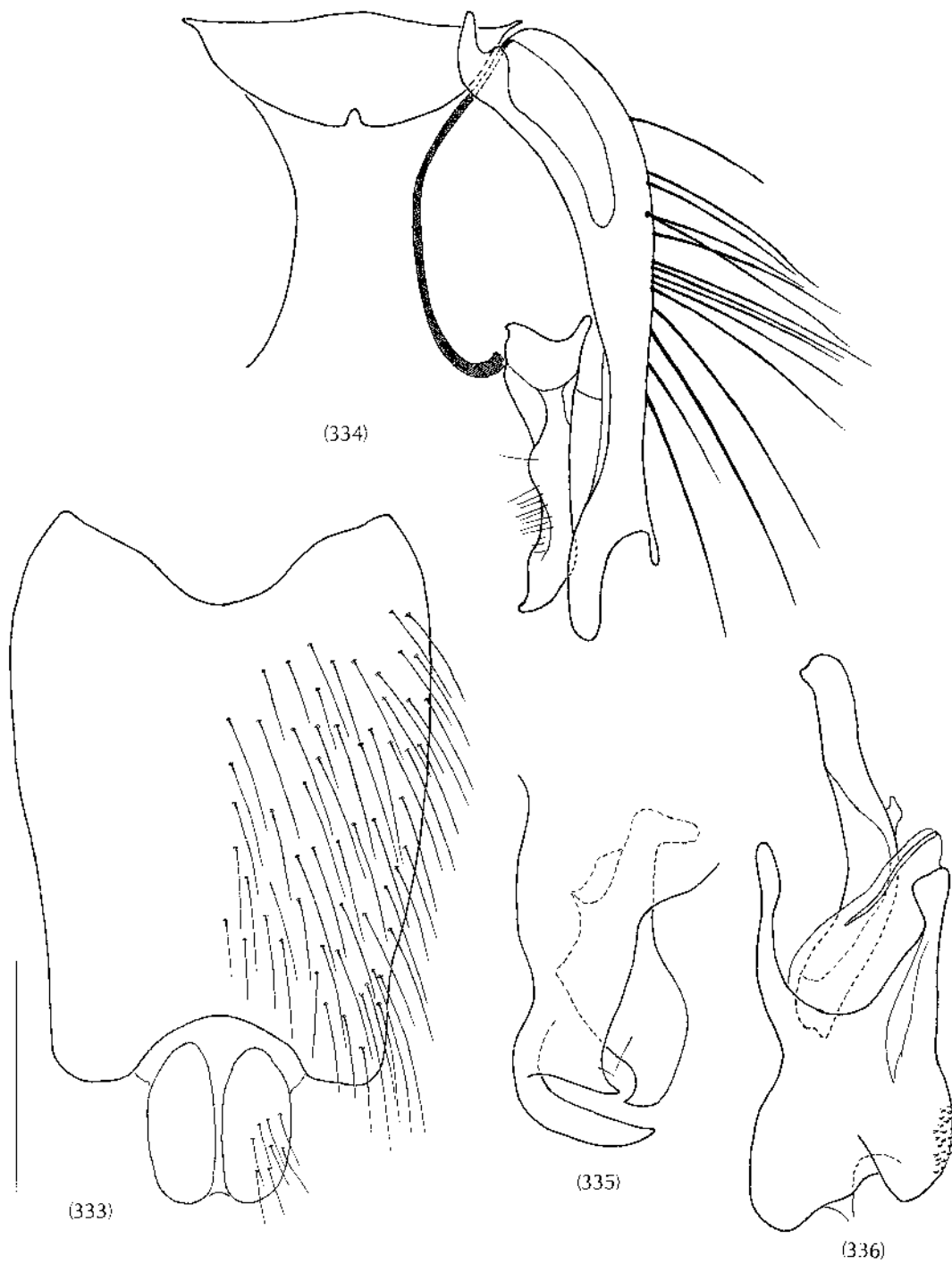

Fig. 333–336 *Ectinorhynchus furcatus*: (333) epandrium and cerci, dorsal; (334) gonocoxite with appendages, dorsal; (335) apex of gonocoxite and inner style, lateral; (336) aedeagus, lateral. Scale line: 0.5 mm.

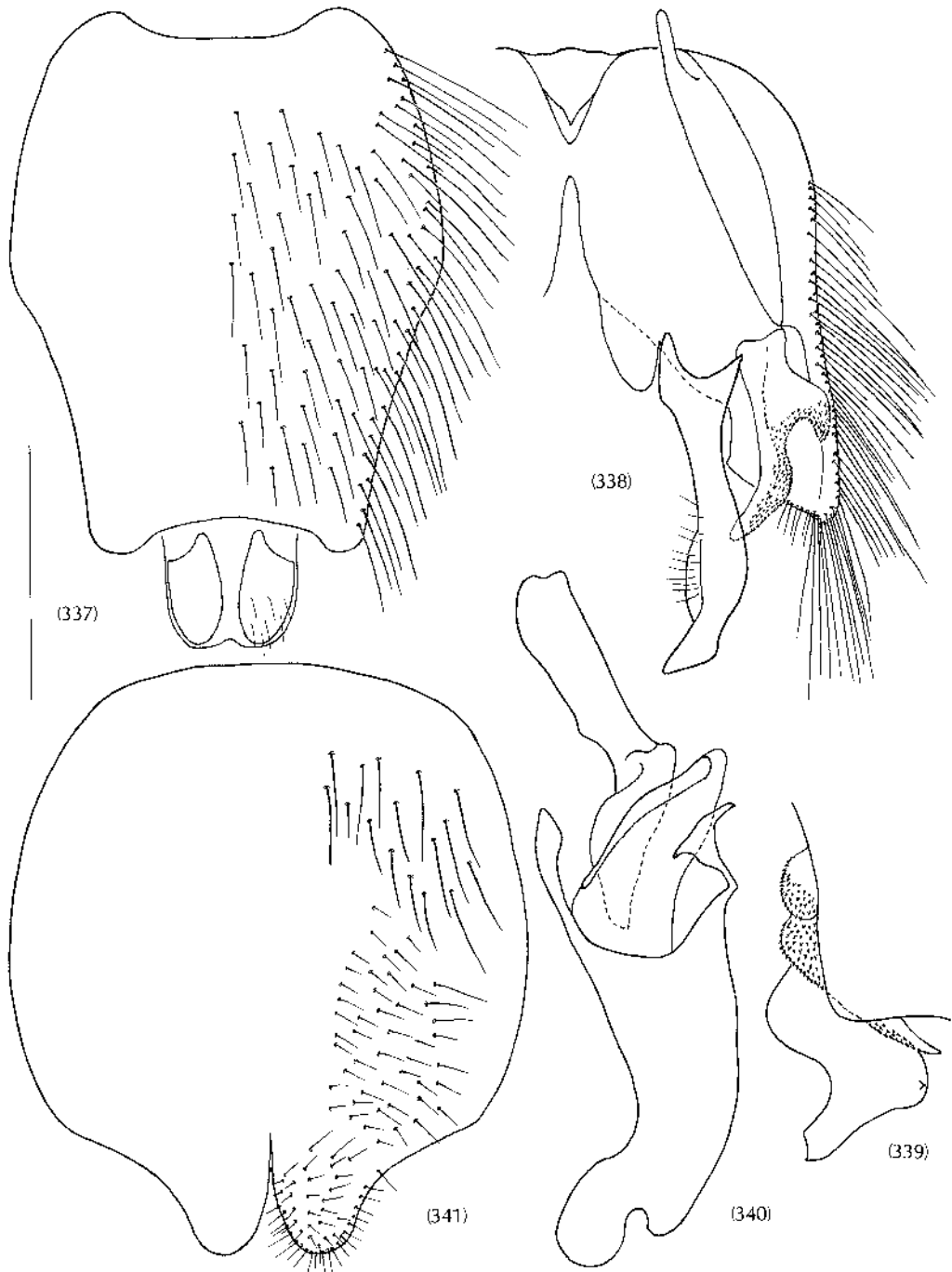

Fig. 337–341 *Ectinorhynchus micans*: (337) epandrium and cerci, dorsal; (338) gonocoxite with appendages, dorsal; (339) outer and inner styles, lateral; (340) aedeagus, lateral; (341) female sternite 8, face view. Scale line: 0.5 mm.

TAXONOMIC INDEX

This index covers the nominal taxa of Therevidae and other arthropod groups mentioned in the text, regardless of their status in taxonomy. Page numbers in bold type denote descriptions of taxa, and in italic type illustrations. A suffixed letter 'k' indicates a key.

- Acrosathe* 10
Acropisa 10
acuminatus, Anabarhynchus 19k, 23, 59, 79, 113
Acupalpa 10
Agapophytus 10
albipennis, Anabarhynchus 18k, 23, 79
albipes, Podagrītus 40
albopilosa, Megathereva 10, 12, 21k, 67, 69, 78, 127, 128
Anabarhynchus 8–13, 15k, 16k, 22, 66, 67, 70
arenarius, Anabarhynchus 17k, 18k, 24, 30, 57, 80, 113
 ASILIDAE 9
 ASILOIDEA 9
Ataenogera 10
atratus, Anabarhynchus 16k, 25, 67, 80
atripes, Anabarhynchus 11, 18k, 22, 25, 61, 81, 113
arītibia, Megathereva 8, 21k, 51, 67, 68, 69, 127, 128
aureosericeus, Anabarhynchus 20k, 26, 82, 114
- bilineata, Bibio* 8, 66, 69
 Megathereva 21k, 67–69, 128
 Thereva 8
bilineatus, Anabarhynchus 67, 68
brevicornis, Anabarhynchus 20k, 27, 58, 81, 114
brunninervis, Anabarhynchus 17k, 18k, 28, 62, 82, 84, 114
- caesius, Anabarhynchus* 8, 21k, 28, 35, 83, 114
calceatus, Anabarhynchus 8
castaneus, Anabarhynchus 70
 Ectinorhynchus 8, 21k, 70, 72, 74, 129
completus, Anabarhynchus 16k, 25, 29, 54, 83, 115
cora, Podagrītus 40
cupreus, Anabarhynchus 71
 Ectinorhynchus 8, 13, 21k, 71, 77, 130
curvistylus, Anabarhynchus 19k, 30, 84, 115
- Dialineura* 10
diversicolor, Anabarhynchus 20k, 31, 85, 115
- dugdalei, Anabarhynchus* 18k, 32, 86, 116
dysmachiiformis, Anabarhynchus 19k, 32, 87, 116
- Ectinorhynchus* 10–12, 15k, 21k, 69
embersoni, Anabarhynchus 19k, 33, 39, 88, 116
Eupsilocephala 10
exiguus, Anabarhynchus 8, 18k, 34, 85, 117
- farinosus, Anabarhynchus* 21k, 34, 89, 117
fasciatus, Anabarhynchus 22, 67
femoralis, Anabarhynchus 21k, 27, 35, 48, 89, 117
fenwicki, Anabarhynchus 17k, 36, 57, 63, 90, 117
flaviventris, Anabarhynchus 21k, 31, 37, 90
fluviatilis, Anabarhynchus 17k, 19k, 28, 37, 57, 91, 117
frontalis, Anabarhynchus 50, 51
furcatus, Ectinorhynchus 21k, 71, 131
fuscofemoratus, Anabarhynchus 21k, 38, 91
- gibbsi, Anabarhynchus* 19k, 34, 38, 92, 118
grossus, Anabarhynchus 19k, 39, 93, 118
- harrisi, Anabarhynchus* 10, 13, 17k, 19k, 40, 57, 94, 119
hayakawai, Anabarhynchus 17k, 19k, 24, 40, 94, 119
hudsoni, Anabarhynchus 19k, 41, 45, 95
huttoni, Anabarhynchus 17k, 19k, 42, 95, 119
- indistinctus, Anabarhynchus* 17k, 28, 42, 96
innotata, Thereva 8, 43
innotatus, Anabarhynchus 16k, 35, 43, 74–77, 96, 120
Irwiniella 9
- lacustris, Anabarhynchus* 16k, 44, 54
lateropilosus, Anabarhynchus 20k, 41, 45, 97, 120
latus, Anabarhynchus 19k, 45, 51, 97, 98, 120
limbatinervis, Anabarhynchus 16k, 46, 56, 95, 119
longepilosus, Anabarhynchus 16k, 18k, 47, 98, 121
longipennis, Anabarhynchus 16k, 48, 99, 120
luridus, Anabarhynchus 8, 35, 42–44
- LYCOSIDAE 40
- macfarlanei, Anabarhynchus* 20k, 48, 54, 99, 121
major, Anabarhynchus 20k, 49, 100, 121
maori, Anabarhynchus 8, 10, 18k, 22, 25, 50, 78, 102, 122

- maritimus*, *Anabarthynchus* 10
megalopyge, *Anabarthynchus* 20k, 49, 51, 101, 122
Megathereva 9–13, 15k, 21k, 66, 70
micans, *Anabarthynchus* 72
 Ectinorhynchus 8, 21k, 72, 132
microphallus, *Anabarthynchus* 18k, 20k, 52, 103, 122
modestus, *Anabarthynchus* 43, 44
monticola, *Anabarthynchus* 17k, 52, 57, 102, 122

nebulosus, *Anabarthynchus* 8, 16k, 30, 44, 53, 64, 66, 123
nebulosus-group 11, 22, 30, 44, 64–66, 104
neglectus, *Anabarthynchus* 20k, 49, 54, 103, 123
nigrofemoratus, *Anabarthynchus* 19k, 55, 105, 123
nitidiventris, *Priocnemis* (*Trichocurgus*) 40
novazealandiae, *Neothereva* 34
nudifemoratus, *Anabarthynchus* 22

olivaceus, *Anabarthynchus* 16k, 56, 123
ostentatus, *Anabarthynchus* 17k, 28, 56, 104, 124

Pandivirilia 10
 PLYCINAE 9, 10
Phycus 10
Platycarenum 10
postocularis, *Anabarthynchus* 11, 20k, 27, 28, 57, 106, 123

quinquevittata, *Platycarenum* 10

 RHAGIONIDAE 9

robustus, *Anabarthynchus* 16k, 23, 58, 105, 124
ruficoxa, *Anabarthynchus* 20k, 59, 106, 124
rufobasalis, *Anabarthynchus* 18k, 31, 59, 107, 125

 SCENOPINIDAE 9
schlingeri, *Anabarthynchus* 19k, 60, 108, 125
similis, *Anabarthynchus* 18k, 25, 26, 61, 109, 126
simplex, *Anabarthynchus* 18k, 61, 109
spiniger, *Anabarthynchus* 17k, 18k, 28, 62, 84, 110, 125
spitzeri, *Anabarthynchus* 17k, 37, 63, 110
superba, *Schoutedenomyia* 9

Taenogera 10
terrenus, *Anabarthynchus* 22
Thereva 9, 10, 12
 THEREVINAE 9
thoracicus, *Anabarthynchus* 54, 55
triangularis, *Anabarthynchus* 21k, 63, 111, 125
Tribolium 13
tricoloratus, *Anabarthynchus* 16k, 54, 64, 111, 124

variabilis, *Ectinorhynchus* 70
 Thereva 69
viduus, *Saropogon* 8, 51

waitarerensis, *Anabarthynchus* 19k, 64, 112, 126
westlandensis, *Anabarthynchus* 16k, 54, 65, 112
wisei, *Anabarthynchus* 18k, 66, 126

Xestomyzini 10

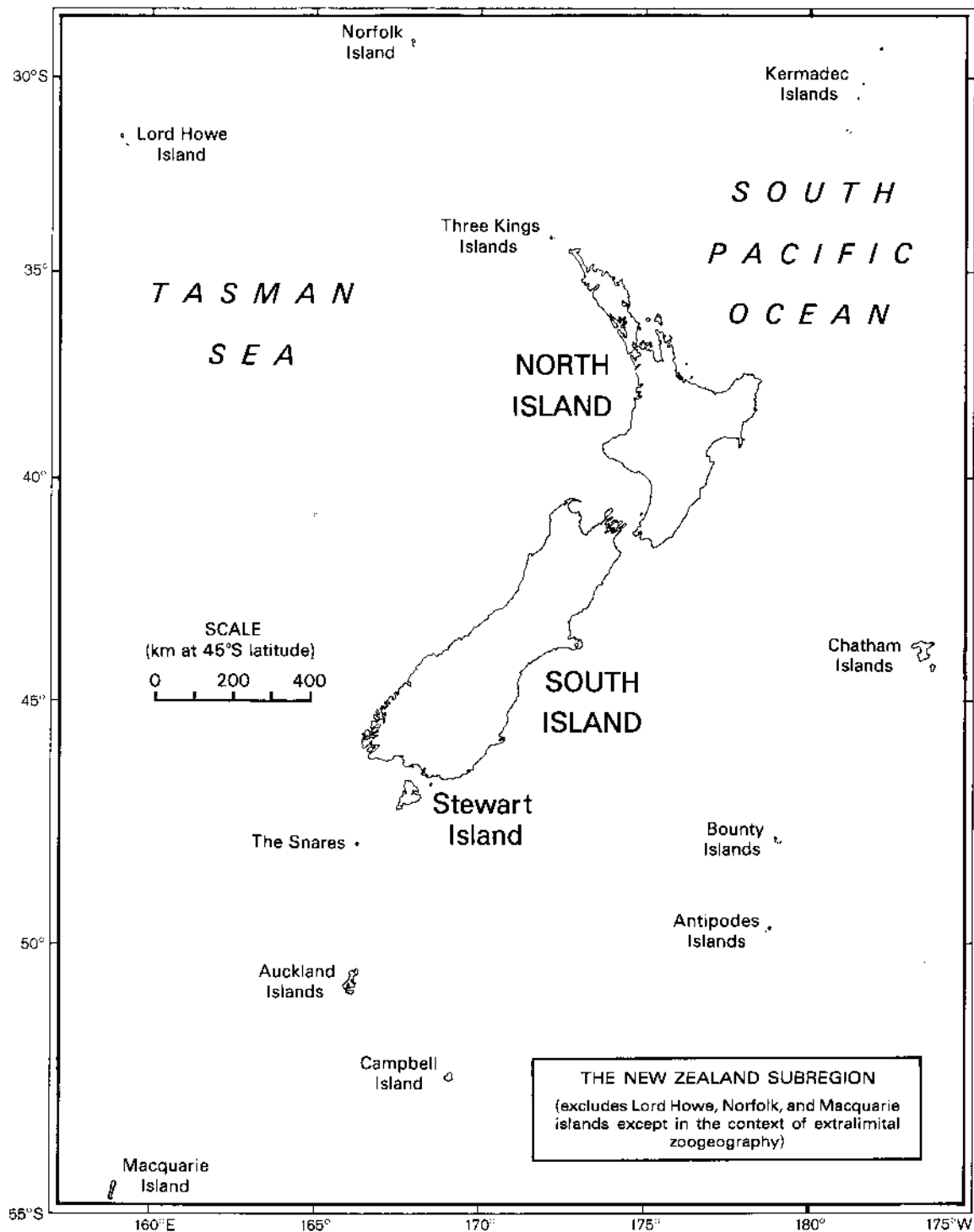

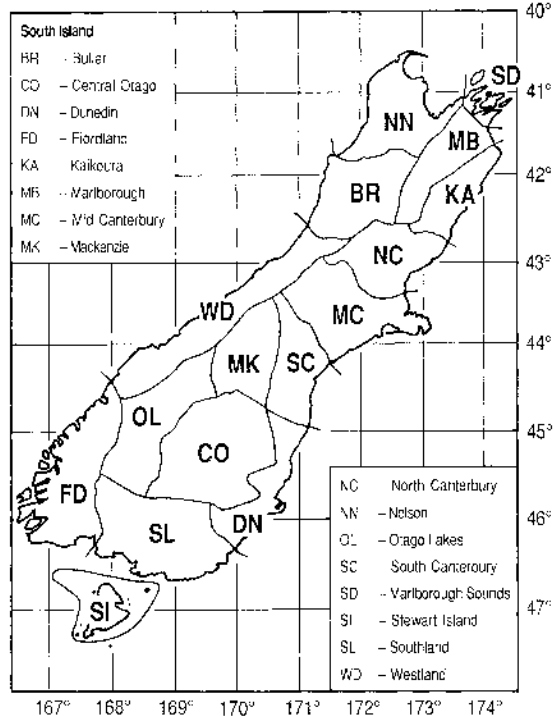
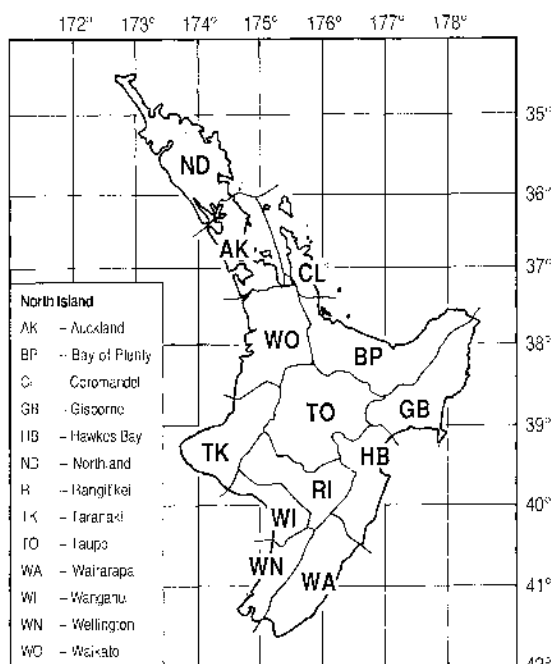

Area codes and boundaries used to categorise specimen locality data (after Crosby *et al.* 1976)

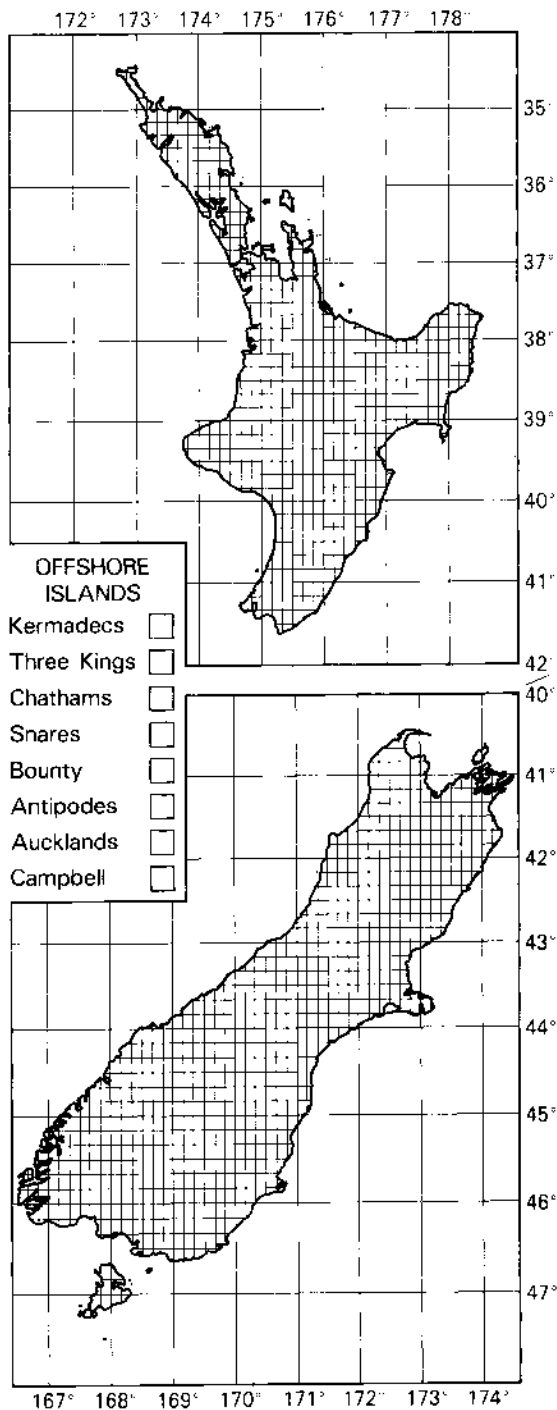

Base-map for plotting collection localities; this may be photocopied without copyright release

TITLES IN PRINT / PUNA TAITARA TAA

- | | | |
|----|--|---------|
| 1 | Terebrantia (Insecta: Thysanoptera) • <i>Laurence A. Mound & Annette K. Walker</i>
ISBN 0-477-06687-9 • 23 Dec 1982 • 120 pp. | \$29.95 |
| 2 | Osoriinae (Insecta: Coleoptera: Staphylinidae) • <i>H. Pauline McColl</i>
ISBN 0-477-06688-7 • 23 Dec 1982 • 96 pp. | \$18.60 |
| 3 | Anthribidae (Insecta: Coleoptera) • <i>B.A. Holloway</i>
ISBN 0-477-06703-4 • 23 Dec 1982 • 272 pp. | \$41.00 |
| 4 | Eriophyoidea except Eriophyinae (Arachnida: Acari) • <i>D.C.M. Manson</i>
ISBN 0-477-06745-X • 12 Nov 1984 • 144 pp. | \$29.95 |
| 5 | Eriophyinae (Arachnida: Acari: Eriophyoidea) • <i>D.C.M. Manson</i>
ISBN 0-477-06746-8 • 14 Nov 1984 • 128 pp. | \$29.95 |
| 6 | Hydraenidae (Insecta: Coleoptera) • <i>R.G. Ordish</i>
ISBN 0-477-06747-6 • 12 Nov 1984 • 64 pp. | \$18.60 |
| 7 | Cryptostigmata (Arachnida: Acari) – a concise review • <i>M. Luxton</i>
ISBN 0-477-06762-X • 8 Dec 1985 • 112 pp. | \$29.95 |
| 8 | Calliphoridae (Insecta: Diptera) • <i>James P. Dear</i>
ISBN 0-477-06764-6 • 24 Feb 1986 • 88 pp. | \$18.60 |
| 9 | Protura (Insecta) • <i>S.L. Tuxen</i>
ISBN 0-477-06765-4 • 24 Feb 1986 • 52 pp. | \$18.60 |
| 10 | Tubulifera (Insecta: Thysanoptera) • <i>Laurence A. Mound & Annette K. Walker</i>
ISBN 0-477-06784-0 • 22 Sep 1986 • 144 pp. | \$34.65 |
| 11 | Pseudococcidae (Insecta: Hemiptera) • <i>J.M. Cox</i>
ISBN 0-477-06791-3 • 7 Apr 1987 • 232 pp. | \$49.95 |
| 12 | Pompilidae (Insecta: Hymenoptera) • <i>A.C. Harris</i>
ISBN 0-477-02501-3 • 13 Nov 1987 • 160 pp. | \$39.95 |
| 13 | Encyrtidae (Insecta: Hymenoptera) • <i>J.S. Noyes</i>
ISBN 0-477-02517-X • 9 May 1988 • 192 pp. | \$44.95 |
| 14 | Lepidoptera – annotated catalogue , and keys to family-group taxa
• <i>J. S. Dugdale</i> • ISBN 0-477-02518-8 • 23 Sep 1988 • 264 pp. | \$49.95 |
| 15 | Ambositrinae (Insecta: Hymenoptera: Diapriidae) • <i>I.D. Naumann</i>
ISBN 0-477-02535-8 • 30 Dec 1988 • 168 pp. | \$39.95 |
| 16 | Nepticulidae (Insecta: Lepidoptera) • <i>Hans Donner & Christopher Wilkinson</i>
ISBN 0-477-02538-2 • 28 Apr 1989 • 92 pp. | \$22.95 |
| 17 | Mymaridae (Insecta: Hymenoptera) • <i>J.S. Noyes & E.W. Valentine</i>
ISBN 0-477-02542-0 • 28 Apr 1989 • 100 pp. | \$24.95 |
| 18 | Chalcidoidea (Insecta: Hymenoptera) – introduction, and review of smaller families
• <i>J.S. Noyes & E.W. Valentine</i> • ISBN 0-477-02545-5 • 2 Aug 1989 • 96 pp. . | \$24.95 |

- 19 **Mantodea** (Insecta), with a review of aspects of functional morphology and biology • *G.W. Ramsay* • ISBN 0-477-02581-1 • 13 Jun 1990 • 96 pp. .. \$24.95
- 20 **Bibionidae** (Insecta: Diptera) • *Roy A. Harrison*
ISBN 0-477-02595-1 • 13 Nov 1990 • 28 pp. \$14.95
- 21 **Margarodidae** (Insecta: Hemiptera) • *C.F. Morales*
ISBN 0-477-02607-9 • 27 May 1991 • 124 pp. \$34.95
- 22 **Notonemouridae** (Insecta: Plecoptera) • *I.D. McLellan*
ISBN 0-477-02518-8 • 27 May 1991 • 64 pp. \$24.95
- 23 **Sciapodinae, Medeterinae** (Insecta: Diptera) with a generic review of the Dolichopodidae • *D.J. Bickel* • ISBN 0-477-02627-3 • 13 Jan 1992 • 74 pp.. \$27.95
- 24 **Therevidae** (Insecta: Diptera) • *L. Lyneborg*
ISBN 0-477-02632-X • Mar 1992 • 140 pp. \$34.95

NOTICES

This series of refereed occasional publications has been established to encourage those with expert knowledge to publish concise yet comprehensive accounts of elements in the New Zealand fauna. The series is professional in its conception and presentation, yet every effort is made to provide resources for identification and information that are accessible to the non-specialist.

'Fauna of N.Z.' deals with non-marine invertebrates only, since the vertebrates are well documented, and marine forms are covered by the series 'Marine Fauna of N.Z.'.

Contributions are invited from any person with the requisite specialist skills and resources. Material from the N.Z. Arthropod Collection is available for study.

Contributors should discuss their intentions with an appropriate member of the 'Fauna' Advisory Group or with the Series Editor before commencing work; all necessary guidance will be given.

Subscribers should address inquiries to 'Fauna of N.Z.', DSIR Library, Mt Albert Research Centre, Private Bag, Auckland, New Zealand.

Subscription categories: 'A' – standing orders; an invoice will be sent with each new issue, as soon after publication as possible. 'B' – promotional fliers with order forms will be sent from time to time.

Retail prices (see 'Titles in print', page 73) include packaging and surface postage. Subscribers in New Zealand and Australia pay the indicated amount in \$NZ; GST is included in the price. Other subscribers pay the listed price in \$US, or equivalent.

Back issues of all numbers are available, and new subscribers wishing to obtain a full set or a selection may request a discount. Booksellers and subscription agents are offered a trade discount of 20%.

NGA PAANUI

Kua whakatuuria teenei raarangi pukapuka hei whakahau ki nga tohunga whai maaturanga kia whakaatu i nga mea e paa ana ki nga kararehe o Niu Tiireni. He aahua tohunga teenei raarangi pukapuka, engari, ko te hiahia kia maarama ai te tuhituhi, kia moohio ai te maria ki nga tohu o ia ngaarara, o ia ngaarara, aa, kia whakaari i te maaturanga e paa ana ki a ratou.

Ko eenei pukapuka 'Fauna of New Zealand' kaaore e paa ana ki nga kararehe, ki nga ika, ki nga maataitai raanei. E tino moohiolia ana nga kararehe. Kei roto i nga pukapuka e kii ana 'Marine Fauna of New Zealand' nga tuhituhi e paa ana ki nga ika me nga maataitai.

Tuhituhinga. Kote tono ki nga tohunga kia tukua mai aa koutou pukapuka. E waatea ana te kohikohinga kararehe e kii ana ko te New Zealand Arthropod Collection hei maatakitaki maau.

Me whaakii oo koutou whakaaro ki te mema o te kaahui tohutohu o 'Fauna' e tika ana, ki te Etita raanei, i mua i te tiimatanga tuhituhi.

Nga kai-hoko pukapuka. Me tuhi ki te 'Fauna of New Zealand' kei te DSIR Library, Mt Albert Research Centre, Private Bag, Auckland, New Zealand.

E rua nga tuumomo kai-hoko: 'A' – Kai-hoko tuumau; ka tukua ia pukapuka, ia pukapuka, me te kaute, i muri tonu i te taanga o taua pukapuka. 'B' – ka tukua nga paanui anake, a toona waa, a toona waa.

Te utu (tirohia te whaarangi 73): Ko te koopakitanga me te pane kuini kei roto i te utu. Me utu koutou e noho ana Niu Tiireni me Aahitereiria ki nga taara o Niu Tiireni. Ko eetahi atu me utu te whakaritenga i nga taara Marikena.

E toe ana nga pukapuka o mua. Mehemea e hiahia ana koe ki te katoa o nga pukapuka, tonoa mai kia heke iho te utu. E rua pai heneti te heke iho o te utu ki nga toa hoko pukapuka.

TOWARDS UNDERSTANDING OF THE NATURAL WORLD

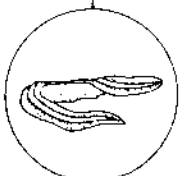
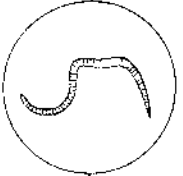
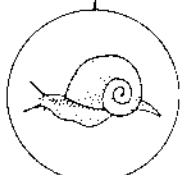
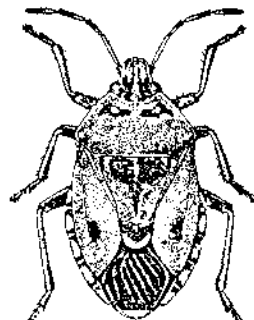
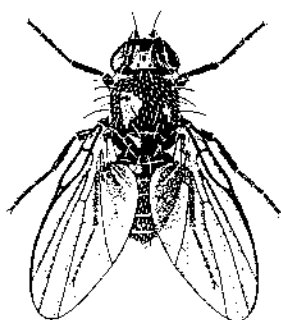
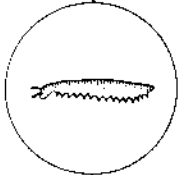
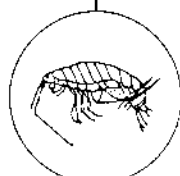
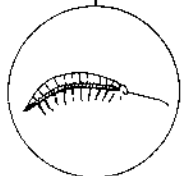
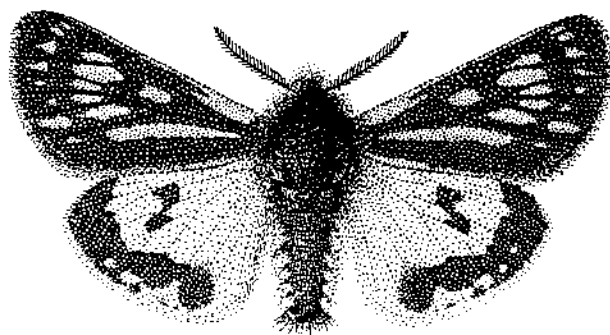
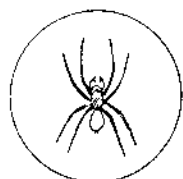

**'LIFEKEYS' and
'FAUNA of NEW ZEALAND'**

Natural science source works from the experts



PLANT PROTECTION
TE WĀHANGA MANAAKI TUPU

• SYSTEMATICS GROUP •

ADDRESS: Mt Albert Research Centre
Private Bag, Auckland, New Zealand

Tel: +64-9-893-660 Fax: +64-9-863-330

NOTE: From July 1992 becoming part of the
National Institute for Land Environments

• SPECIALISTS IN RESEARCH, CONSULTATION, EDUCATION •

**DSIR PLANT
PROTECTION**

**TE WAHANGA
MANAĀKI TUPI**

Beetles in a suburban environment: a New Zealand case study

The identity and status of Coleoptera in the natural and modified habitats of Lynfield, Auckland (1974–1989)

by G. Kuschel

The importance of local biotic surveys cannot be overemphasised at a time when management decisions affecting the future of natural environments are being made at an all too rapid rate. The effects of replacing native bush with agricultural crops, imported plantations, or exotic gardens cannot begin to be estimated without a detailed knowledge of the native flora and fauna. Although it is not uncommon for survey information on higher plants and vertebrates to be available, similar data for terrestrial invertebrates is almost impossible to find. This is one of several reasons why Dr Kuschel's 15 year survey of the Coleoptera of the Lynfield area is an unique and important contribution.

The study was conducted in a suburban environment in New Zealand, a country where numerous exotic plants and animals, principally from the Northern Hemisphere, have been introduced and established over the past 200 years. This feature adds an additional dimension to the work, in that it provides an insight into

the possible interactions between native and exotic species and differences in their habitat preferences. The survey involves almost 1000 species of beetles, three-fourths of which are endemic to New Zealand. For every species recorded, the relative abundance and habitat preferences are given, as well as information on flight capability and, for exotic forms, the country of origin and, if known, the earliest New Zealand record.

Dr Kuschel has combined his own general knowledge of the Coleoptera and expertise in weevil taxonomy with the talents of a number of overseas specialists to provide species names for the majority of the taxa and to place almost all of them in a known genus; he has also described several new species and made other taxonomic changes. Each family is accompanied by at least one illustration, and sections on habitat types and collecting methods are included. An appendix by A.E. Esler includes a vegetation analysis and a list of higher plant species for the area.

This important contribution will prove to be of immense value to entomologists, ecologists, natural historians, and conservationists, not only in New Zealand but in other countries interested in understanding and conserving their natural environment. J.F. Lawrence, CSIRO Division of Entomology



• DSIR Plant Protection Report no. 3 •

Extensively illustrated, largely by Des Helmore

Published December 1990 • 120 pp. A4 • price \$29.95*

*New Zealand and Australia NZ\$29.95, overseas US\$29.95.

Price includes GST (N.Z.), packing, and postage.

Discount of 10% for ten copies or more.

ORDER FORM

Tax invoice (New Zealand): GST no. 23-433-753

Please send me copy / copies of *Beetles in a Suburban Environment* (ISBN 0-477-02596-X)

Name and address (PLEASE PRINT):

Amount due: NZ\$ or US\$ Payment enclosed Please charge

Credit card number: Visa / Mastercard / AmEx

Signature:

Credit card expiry date:

REMITTANCES AND INQUIRIES TO

Library, Mt Albert Research Centre, DSIR, Private Bag, Auckland, New Zealand

Tel: 893-660

Fax: 863-330

Area code: 09 in New Zealand, 064-9 overseas

Fauna of New Zealand

Ko te Aitanga Pepeke o Aotearoa

Number/Nama 24



Therevidae
(Insecta: Diptera)

L. Lyneborg



POPULAR SUMMARY

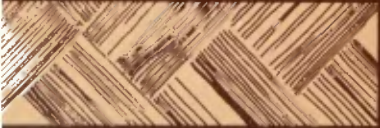

CHECKLIST OF TAXA

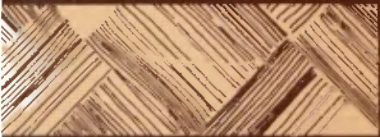

KEYS TO TAXA

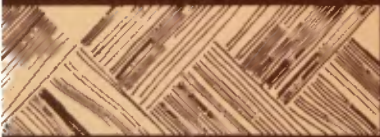

REFERENCES



TAXONOMIC INDEX



This is a PDF facsimile of the printed publication, and is fully searchable. It is supplied for individual use only and is not to be posted on websites (links should be made to the page from which it was downloaded).

No part of this work covered by copyright may be reproduced or copied in any form or by any means (graphic, electronic, or mechanical, including photocopying, recording, taping, information retrieval systems, or otherwise) without the written permission of the publisher.

Fauna of New Zealand website copy 2009,
www.LandcareResearch.co.nz

Lyneborg, L. 1992: Therevidae (Insecta: Diptera). *Fauna of New Zealand* 24, 140 pp.

Date of publication: 4 March 1992
Fauna of New Zealand, ISSN 0111-5383; 24
ISBN 0-477-02632-X

New Zealand Therevidae. Scanned images from BUGZ project (www.bugz.org.nz) provided by Stephen Pawson for OCR. Text OCR'd and corrected for this searchable PDF by Trevor Crosby, FNZ series editor, 6 May 2009. Users may extract text from this PDF for their own use, but must check it against the original document for text sequence, accuracy, and formatting.